

# Haiwell A Series Intelligent HMI

## Haiwell Intelligent HMI Instructions



## Edit History

Date	Author	Revise Content
2025/02/20	Overseas Department	V20250220NO.1
2025/05/27	Overseas Department	V20250527NO.2
2025/08/20	Overseas Department	V20250820NO.3

- V20250527NO.2: Revise the CAD dimensions and update the precision to the decimal point.
- V20250820NO.3: Add the installation method for 15-inch screens.

# Catalogue

<b>I. Product Introduction .....</b>	<b>1</b>
1. Major Function.....	1
2. Core Highlights.....	1
<b>II. Product Specification.....</b>	<b>2</b>
1. Product Parameter Specifications .....	2
2. Product Model List.....	3
<b>III. Description of Products .....</b>	<b>5</b>
1. Product Front Appearance.....	5
2. Product Back Description .....	8
3. Product Size .....	8
4. Product Interface .....	11
4.1 Interface Diagram.....	11
4.2 Definition of Communication Interface.....	12
5. HMI Electrical Connection .....	13
5.1 Power Connection .....	13
5.2 Ethernet Connection.....	13
5.3 Serial Connection .....	14
<b>IV. HMI Installment and Use.....</b>	<b>14</b>
1. Panel Installation.....	14
2. Settlement Installation.....	14
3. Installation of External 4G Card .....	17
4. Antenna Installation .....	18
<b>V. HMI Settings .....</b>	<b>18</b>
1. HMI Supporting Software.....	18
2. HMI Background Settings .....	18
2.1 Background Setting Entry Method.....	18
2.2 Project Settings.....	19
2.3 Local Settings.....	21
2.4 System Information.....	35
2.5 Cloud Settings .....	38
2.6 Network Settings.....	41
<b>VI. Configuration SCADA Project.....</b>	<b>57</b>
1. Project Establishment.....	57
1.1 Add New Project .....	57

1.2 Add New Device .....	58
1.3 Add the New Variables .....	59
1.4 Edit Screen .....	59
1.5 Debugging and Running.....	60
2. Device Management Tool .....	61
2.1 Local Management .....	61
2.2 Cloud Management .....	62
3. Project Download.....	62
3.1 Local Download.....	62
3.2 Remote Download.....	63
4. Project Operation .....	64
5. Local/Remote Access HMI Screen .....	64
5.1 PC Local/Remote Access .....	64
5.2 Remote Access on Mobile.....	67
<b>VII. Remote Transparent Transmission PLC .....</b>	<b>68</b>
1. Modify the Computer Supply Network Segment.....	68
2. Open the Device Management Tool.....	69
3. Connect Transparent Transmission Devices .....	70
4. VPN Status Check.....	71
5. Transparent Transmission PLC .....	73
<b>VIII. HMI Calibration.....</b>	<b>75</b>
1. Enter Calibration Mode.....	75
2. Operation Calibration Mode Interface .....	78
<b>IX. Common Problem.....</b>	<b>79</b>
1. What is the factory IP address of HMI? .....	79
2. How to download projects locally from HMI? .....	79
3. What is the password for uploading HMI factory demonstration project? .....	79
4. Is there any other way to enter HMI background settings besides on the screen? .....	79
5. Can I download programs from HMI's USB and how can I download them?.....	81
6. How to deal with unstable serial communication or offline communication reports between HMI and 485 devices? ..	82
7. How to deal with the normal communication flow meters, electricity meters and other instrumentation equipment, but the value read is not the same?.....	83
8. How to unbind the machine owner AKey in HMI cloud settings?.....	83
9. How to troubleshoot if HMI cloud settings are not online?.....	83
10. How to deal with HMI displaying no service in the background when placing 4G card? .....	84

---

11. How to handle HMI WIFI connection failure? .....	84
12. How to deal with VPN transmission failure to connect to PLC? .....	84
13. How to handle RTSP cameras that can display images but cannot be controlled? .....	84
14. How to handle RTSP access to Hikvision camera and configuration camera example path not displaying? .....	84
<b>Appendix</b> .....	<b>85</b>
1. Self-shopping IoT network card binding domain name collection .....	85

# I. Product Introduction

## 1. Major Function

Haiwell HMI embedded system is developed based on embedded Linux system and is an embedded system software that runs on industrial automation monitoring and management equipment. By running Haiwell configuration project, it can intuitively observe the on-site situation of the industry, communicate with various industrial control devices, and monitor the production signals collected from the industrial site. Timely notify relevant personnel of alarm information on industrial sites through screens, computer language, WeChat, SMS, Email, and other forms. Support the use of network project to enable multiple devices to act as clients and servers for each other, share data through the network, and achieve distributed control. Support recording and storing data. Analyze and analyze real-time and historical operating data to solve production failures, improve production efficiency, and enhance product quality.

## 2. Core Highlights

- LAN interconnection: instant connection with mobile phones, tablets, computers, televisions, cameras, and other HMIs
- Internet of Things function: instant connection with computers, tablets, computers, televisions, cameras and other HMI through the Internet
- Remote access: Breaking the traditional VNC protocol, no need for secondary configuration, what you get is what you get; Holding asynchronous synchronous monitoring for multiple people simultaneously
- Data Security: All data can be transmitted and stored on designated servers, deployed locally or on the public network, and is secure and controllable
- Open interface: Supports MQTT, OPCUA, HTTP, TCP and other interfaces to easily integrate with ERP, MES and other third-party applications
- Screen integration: third-party software APP、 Mini programs and other applications can directly embed HMI screens, instantly possessing remote control capabilities for devices
- Device intelligence: supports applications such as text to speech broadcasting, full scene voice intercom, audio file playback, camera monitoring, RFID/NFC recognition, etc
- Electronic Dashboard: By networking with Haiwell TVBOX, it can easily meet large screen application scenarios such as data visualization and centralized device monitoring, achieving intelligent work
- Satellite positioning: supports Beidou positioning and trajectory tracking, making device positioning more accurate and achieving functions such as dynamic trajectory tracking and electronic fencing
- New definition of HMI: The entire series adopts high-definition screen, narrow border design, built-in eSIM, microphone, speaker, RFID components

## II. Product Specification

### 1. Product Parameter Specifications

Specification Parameters		A7	A7 Pro	A10	A10 Pro	A15	A15 Pro
Software	Programming management software	Haiwell Cloud Configuration SCADA					
Display	Monitor	7" TFT		10.1" TFT		15.6" TFT	
	Resolution	1024x600 pixels		1280x800 pixels		1920x1080 pixels	
	Colour	16.7M				262K	
	Brightness	450 cd/m <sup>2</sup>		400 cd/m <sup>2</sup>		350 cd/m <sup>2</sup>	
	Viewing angle	85°/85°/85°/85°		85°/85°/85°/85°		85°/85°/85°/85°	
	Touch type	Resistance-type				Capacitive-type	
Backlight	Backlight Type	LED					
	Lifespan of backlight	50,000 hours					
	Automatic sleep function	Support, Configurable					
Hardware	Flash	8G					
	RAM	512M	1G	1G	1G	1G	1G
	Ethernet port	10/100 Base-T*1	10/100 Base-T*2	10/100 Base-T*1	10/100 Base-T*2	10/100 Base-T*2	
	Serial port	COM1: RS232*1 COM2: RS485*1 COM3: RS485*1					
	USB Host	USB2.0 * 1	USB2.0 * 2	USB2.0 * 1	USB2.0 * 2	USB2.0 * 2	USB2.0 * 2
	RTC	Built in real-time clock					
	Power supply	Input power supply	24V DC±20%				
Power consumption		12W@24VDC	15W@24VDC	13W@24VDC	17W@24VDC	23W@24VDC	
Power protection		Equipped with surge protection and anti reverse connection protection					
Withstanding voltage		500V AC					
Insulation impedance		Exceed 50MΩ @500VDC					
Environment	Cooling method	Natural wind cooling					
	Protection grade	The panel meets IP65 and the body meets IP20					
	Storage environment temperature	-20℃ ~ +70℃					
	Operating ambient temperature	-10℃ ~ +60℃					
	Relative humidity	10% ~ 90% RH (no condensation)					
	Vibration resistance	10~25 Hz (X.Y and Z axis 2G/30 minutes )					
	Usage environment	Dustproof, moisture-proof, corrosion-resistant, and protected from electric shock and external impact environments					
Specifications	Shell material	Engineering plastic ABS (flame retardant grade)				Engineering plastic ABS+PC (flame retardant grade) +Glass panel	
	External dimensions (WxHxD)	193x120x32mm		260x167x32mm		394x256x45mm	

	Hole size (WxH)	187x114mm (R7mm)		254x161mm (R7mm)		383x245mm (R7mm)	
	Weight	0.8kg		1.1kg		2.5kg	
	Installation method	Panel installation				Panel installation, VESA(75*75)	
Function	WIFI	Supports 802.11b/g/n, optional					
	Wireless network	Supports 4G full network connectivity (with built-in eSIM), optional					
	RFID	Not Supported	Standard Configuration	Not Supported	Standard Configuration	Not Supported	Standard Configuration
	Satellite positioning	Optional					
	Microphone	External	Built-in	External	Built-in	External	Built-in
	Speaker	Built-in					
	Certification	Certification type	CE				

## 2. Product Model List

Model	TFT screen	Storage	LAN+COM	USB	Intelligent configuration	Voice	Local video	RFID	Satellite positioning	WIFI	Wireless network	Hole size W*H (mm)	Product size W*H*D (mm)
A7	7" 1024*600 HD	8G+512M	1+3	1	speaker	Yes						187*114 chamfer: R7mm	193*120*32
A7-G		8G+512M	1+3	1	speaker	Yes					*Built-in eSIM		
A7-W		8G+512M	1+3	1	speaker	Yes				Yes			
A7-GP		8G+512M	1+3	1	speaker	Yes			Yes		*Built-in eSIM		
A7-GW		8G+512M	1+3	1	speaker	Yes				Yes	*Built-in eSIM		
A7-E		8G+512M	1+3	1	speaker	Yes					Global 4G		
A7-EW		8G+512M	1+3	1	speaker	Yes				Yes	Global 4G		
A7 Pro		8G+1G	2+3	2	microphone, speaker	Yes	Yes	Yes					
A7 Pro-G		8G+1G	2+3	2	microphone, speaker	Yes	Yes	Yes			*Built-in eSIM		
A7 Pro-W		8G+1G	2+3	2	microphone, speaker	Yes	Yes	Yes		Yes			
A7 Pro-GP		8G+1G	2+3	2	microphone, speaker	Yes	Yes	Yes	Yes		*Built-in eSIM		
A7 Pro-GW		8G+1G	2+3	2	microphone, speaker	Yes	Yes	Yes		Yes	*Built-in eSIM		
A7 Pro-E		8G+1G	2+3	2	microphone, speaker	Yes	Yes	Yes			Global 4G		
A7 Pro-EW		8G+1G	2+3	2	microphone, speaker	Yes	Yes	Yes		Yes	Global 4G		
A10		10.1" 1280*800 HD	8G+1G	1+3	1	speaker	Yes						
A10-G	8G+1G		1+3	1	speaker	Yes					*Built-in eSIM		
A10-W	8G+1G		1+3	1	speaker	Yes				Yes			
A10-GP	8G+1G		1+3	1	speaker	Yes			Yes		*Built-in eSIM		
A10-GW	8G+1G		1+3	1	speaker	Yes				Yes	*Built-in eSIM		

A10-E		8G+1G	1+3	1	speaker	Yes					Global 4G		
A10-EW		8G+1G	1+3	1	speaker	Yes				Yes	Global 4G		
A10 Pro		8G+1G	2+3	2	microphone, speaker	Yes	Yes	Yes					
A10 Pro-G		8G+1G	2+3	2	microphone, speaker	Yes	Yes	Yes			*Built-in eSIM		
A10 Pro-W		8G+1G	2+3	2	microphone, speaker	Yes	Yes	Yes		Yes			
A10 Pro-GP		8G+1G	2+3	2	microphone, speaker	Yes	Yes	Yes	Yes		*Built-in eSIM		
A10 Pro-GW		8G+1G	2+3	2	microphone, speaker	Yes	Yes	Yes		Yes	*Built-in eSIM		
A10 Pro-E		8G+1G	2+3	2	microphone, speaker	Yes	Yes	Yes			Global 4G		
A10 Pro-EW		8G+1G	2+3	2	microphone, speaker	Yes	Yes	Yes		Yes	Global 4G		
A15		15.6" 1920*1080 HD capacitive touch screen	8G+1G	2+3	2	speaker	Yes						
A15-G	8G+1G		2+3	2	speaker	Yes					*Built-in eSIM		
A15-W	8G+1G		2+3	2	speaker	Yes				Yes			
A15-GP	8G+1G		2+3	2	speaker	Yes			Yes		*Built-in eSIM		
A15-GW	8G+1G		2+3	2	speaker	Yes				Yes	*Built-in eSIM		
A15-E	8G+1G		2+3	2	speaker	Yes					Global 4G		
A15-EW	8G+1G		2+3	2	speaker	Yes				Yes	Global 4G		
A15 Pro	8G+1G		2+3	2	microphone, speaker	Yes	Yes	Yes					
A15 Pro-G	8G+1G		2+3	2	microphone, speaker	Yes	Yes	Yes			*Built-in eSIM		
A15 Pro-W	8G+1G		2+3	2	microphone, speaker	Yes	Yes	Yes		Yes			
A15 Pro-GP	8G+1G		2+3	2	microphone, speaker	Yes	Yes	Yes	Yes		*Built-in eSIM		
A15 Pro-GW	8G+1G		2+3	2	microphone, speaker	Yes	Yes	Yes		Yes	*Built-in eSIM		
A15 Pro-E	8G+1G		2+3	2	microphone, speaker	Yes	Yes	Yes			Global 4G		
A15 Pro-EW	8G+1G		2+3	2	microphone, speaker	Yes	Yes	Yes		Yes	Global 4G		

Note: The functions marked with \* are only available in China.

### III. Description of Products

#### 1. Product Front Appearance

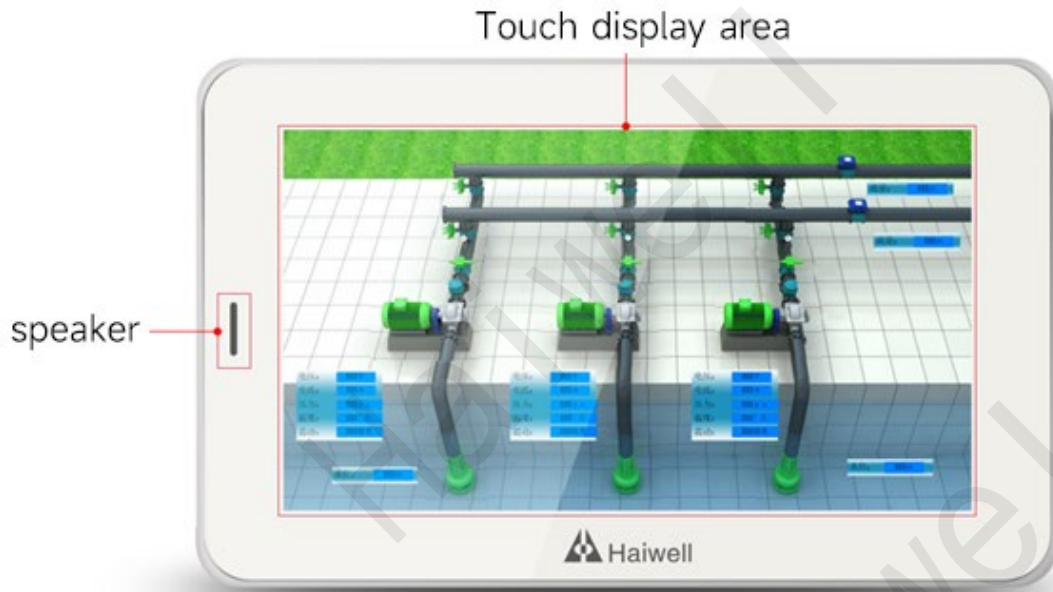

Figure1 HMI A7

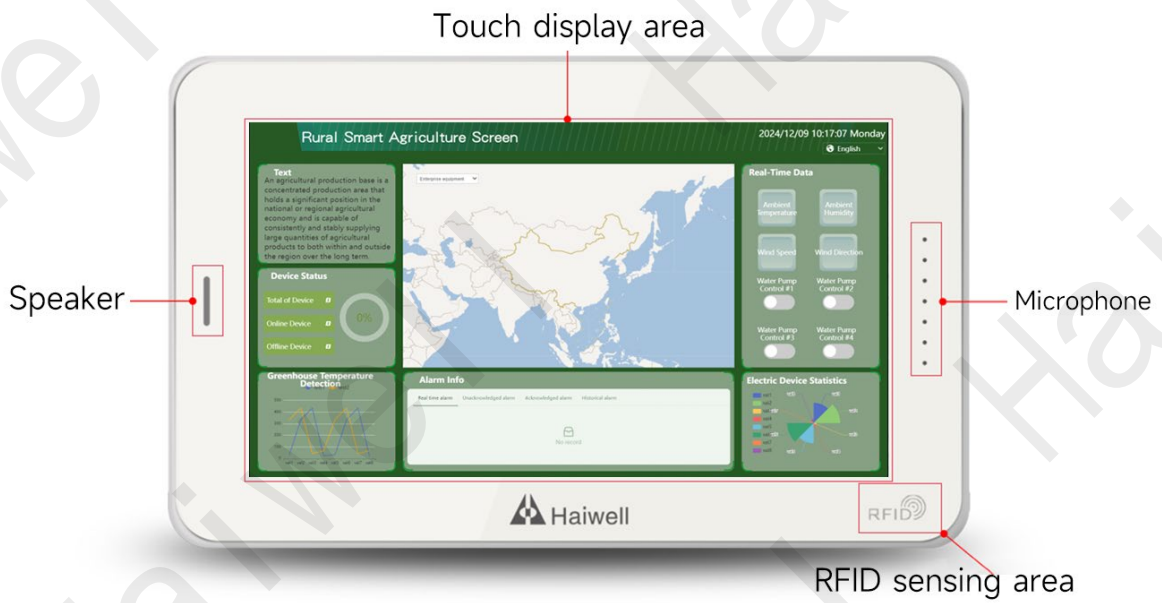

Figure2 HMI A7 Pro

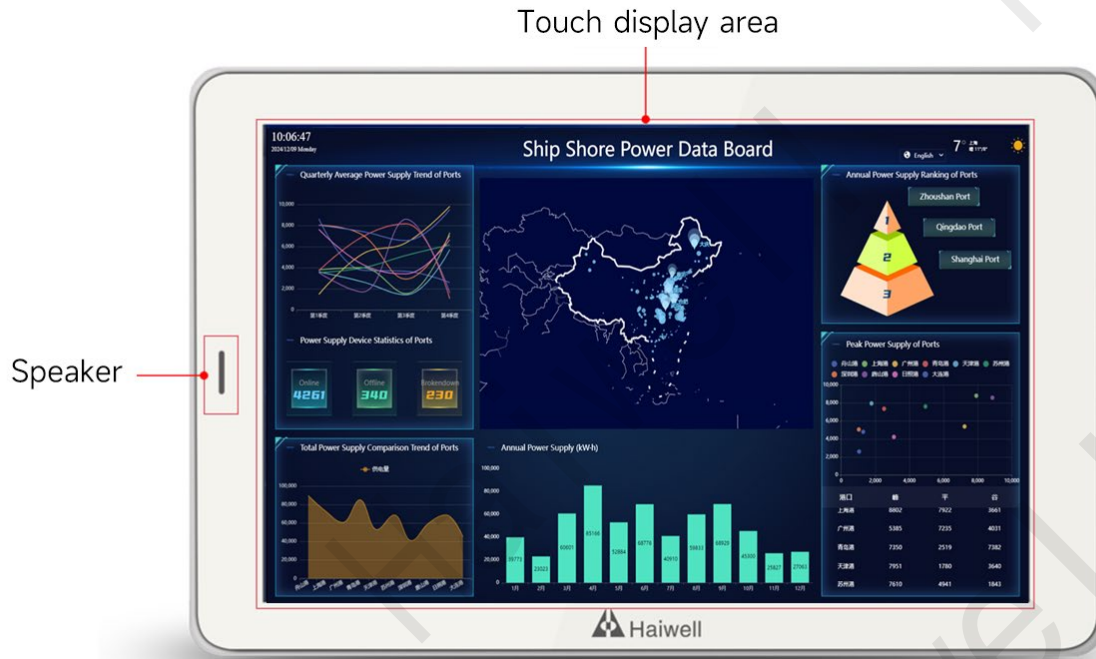
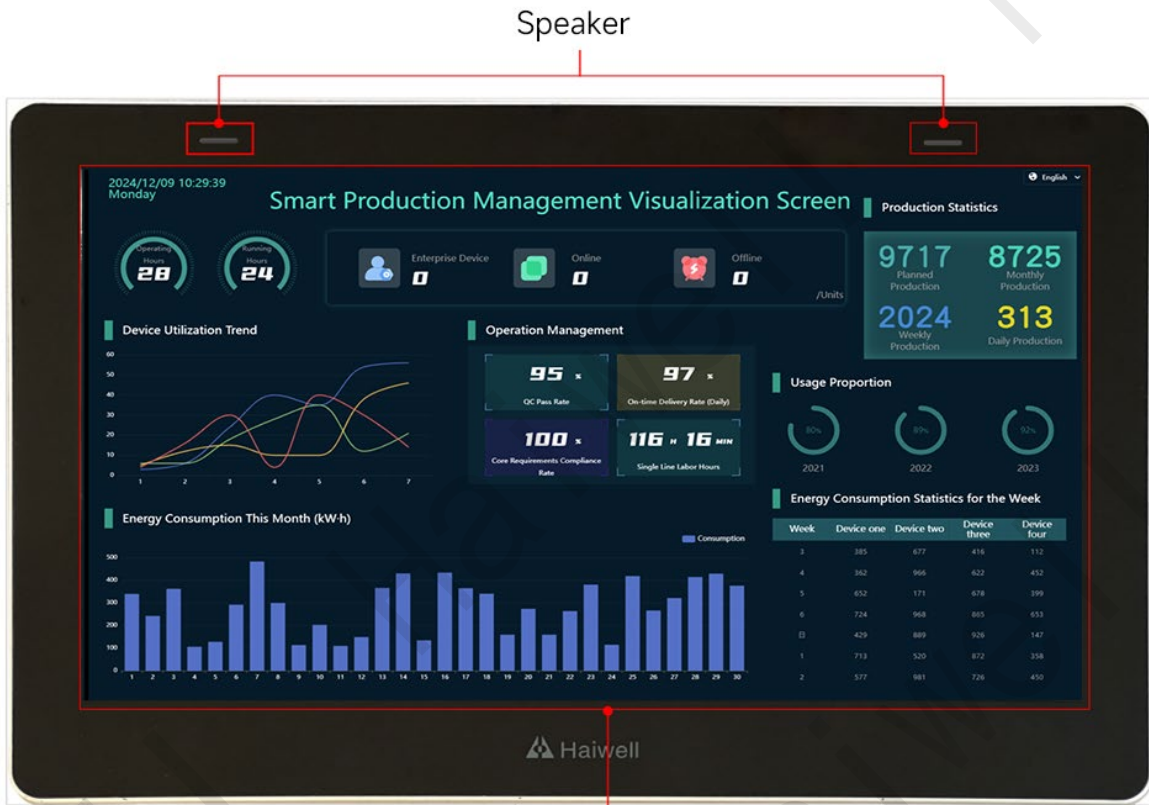

Figure3 HMI A10

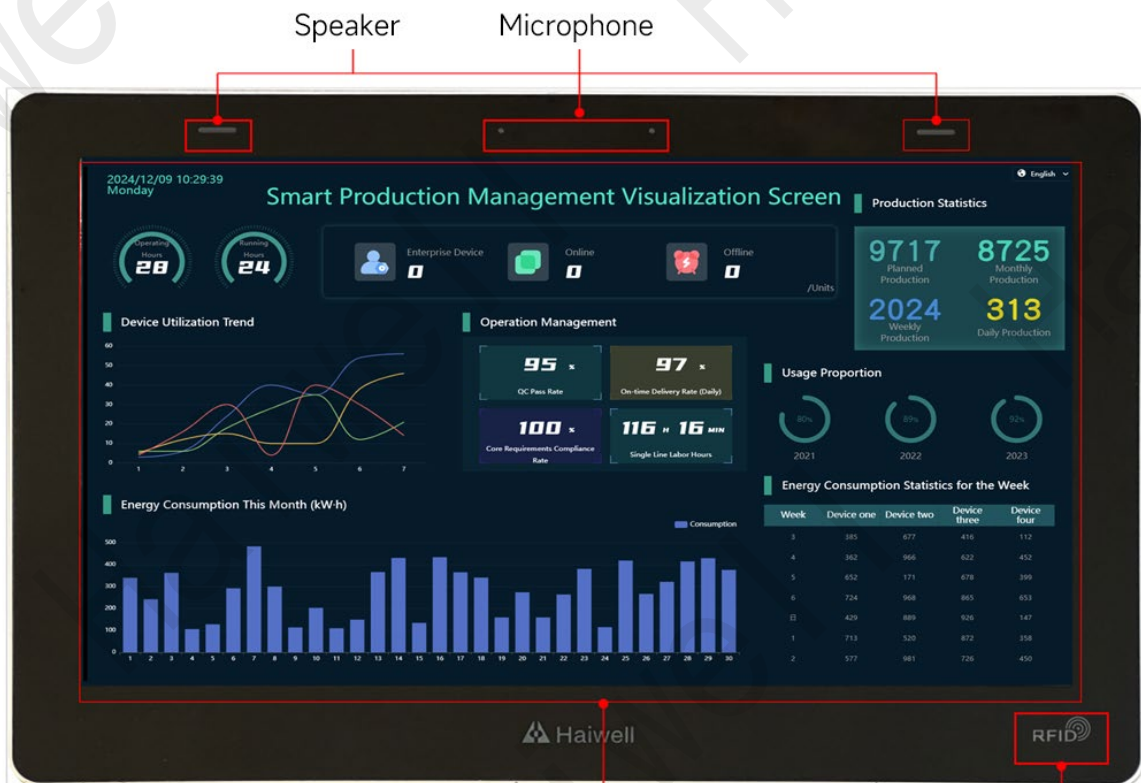

Figure4 HMI A10 Pro



Touch display area

Figure5 HMI A15



Touch display area

RFID sensing area

Figure6 HMI A15 Pro

## 2. Product Back Description

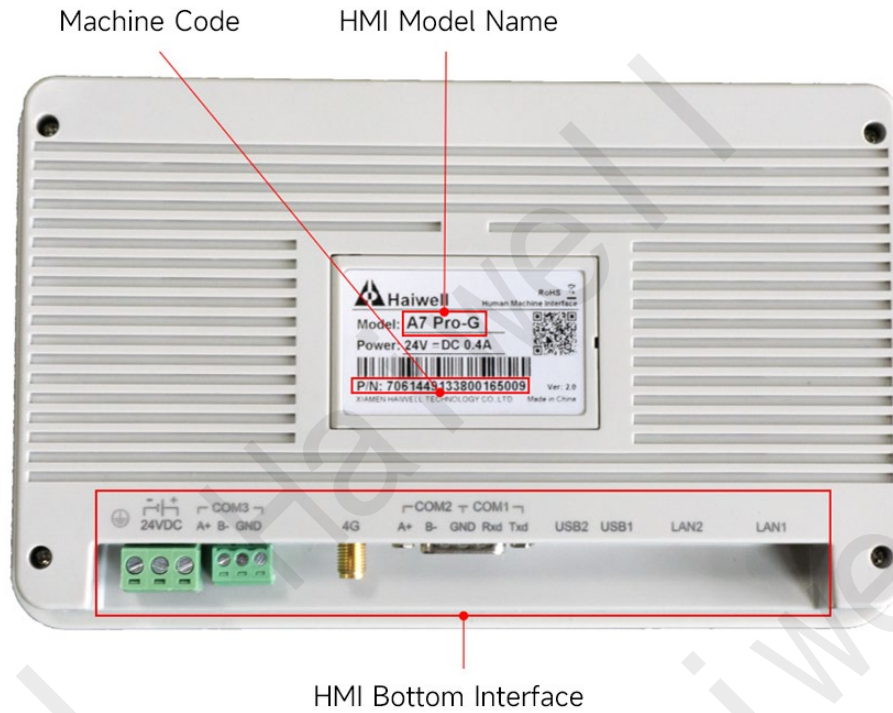

Figure7 HMI Back Description

## 3. Product Size

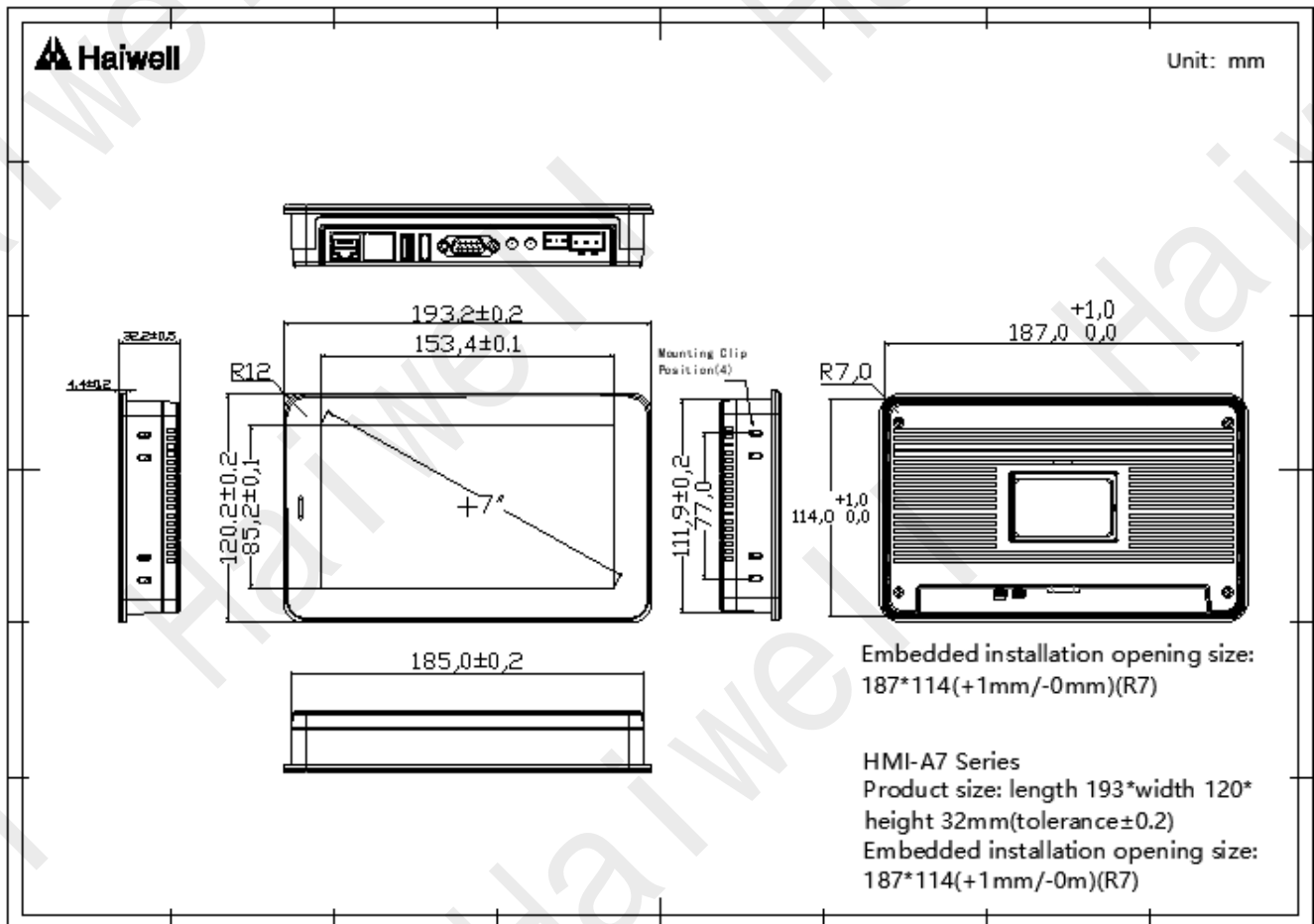

Figure8 HMI A7

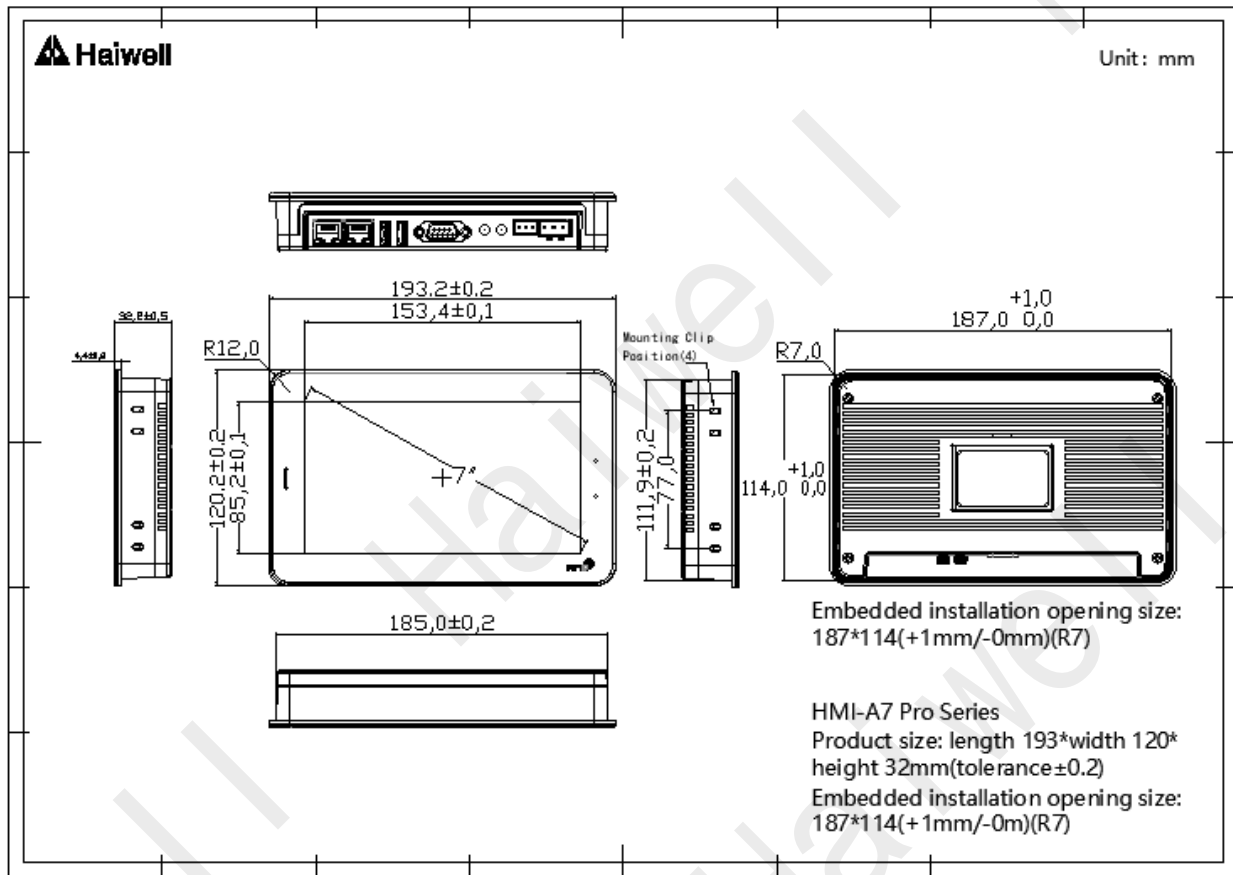

Figure9 HMI A7 Pro

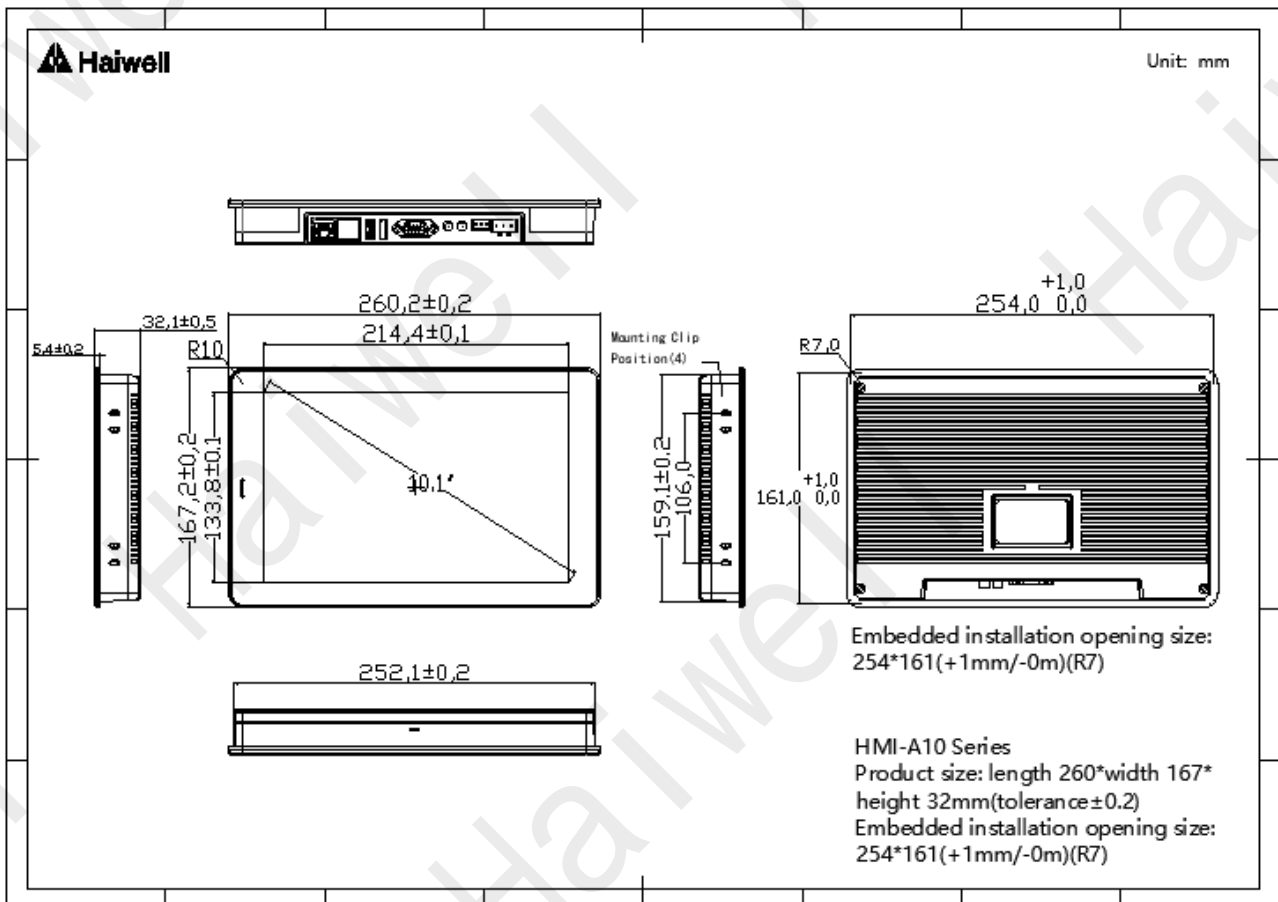

Figure10 HMI A10

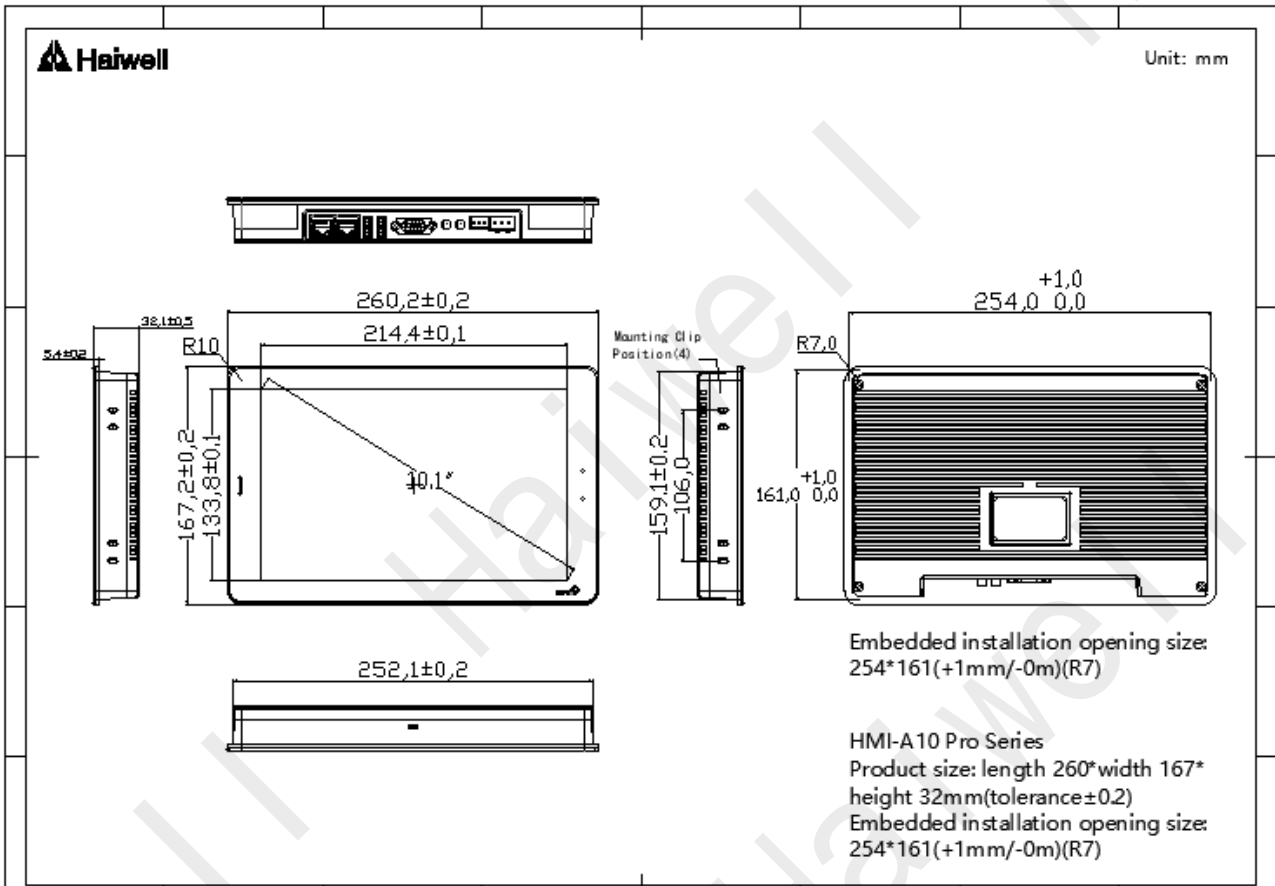

Figure11 HMI A10 Pro

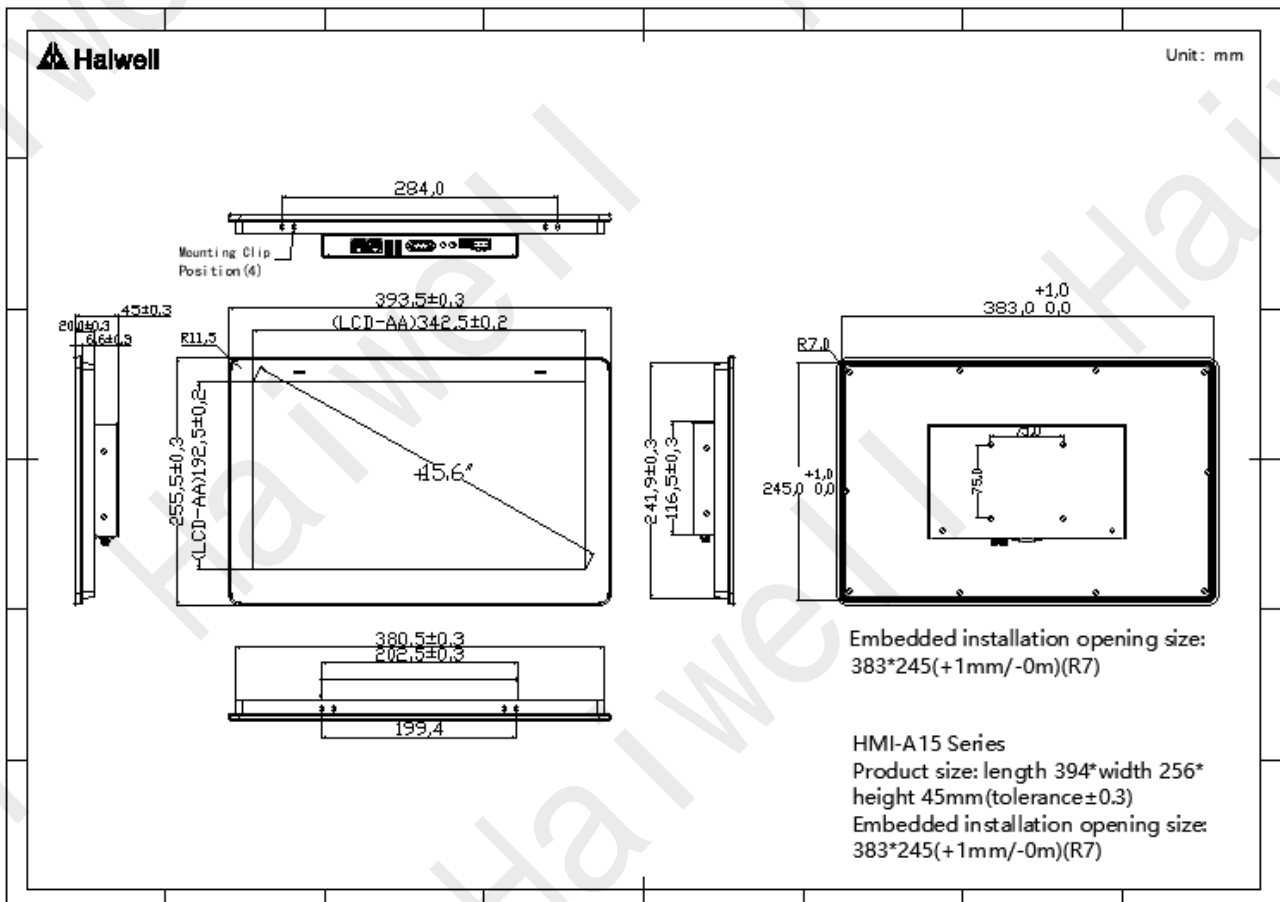

Figure12 HMI A15

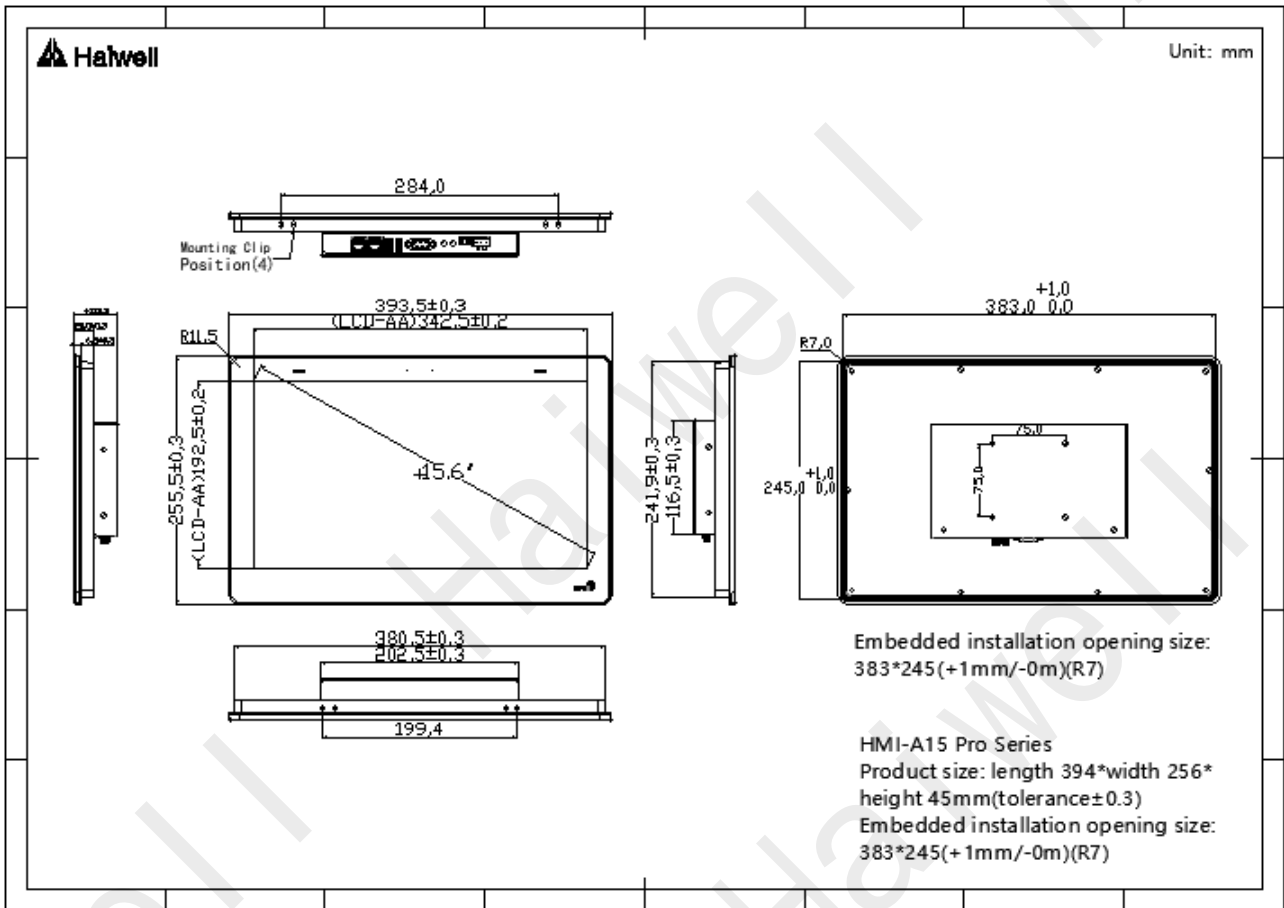

Figure13 HMI A15 Pro

## 4. Product Interface

### 4.1 Interface Diagram

#### ①HMI A7/A7-G/A7-W/A7-GP/A7-GW/A7-E/A7-EW

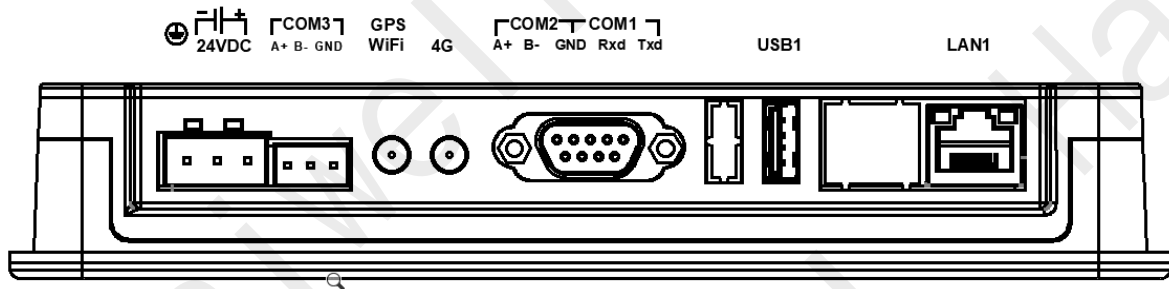

Figure14 HMI A7 Common Interface

#### ②HMI A7 Pro/A7 Pro-G/A7 Pro-W/A7 Pro-GP/A7 Pro-GW/A7 Pro-E/A7 Pro-EW

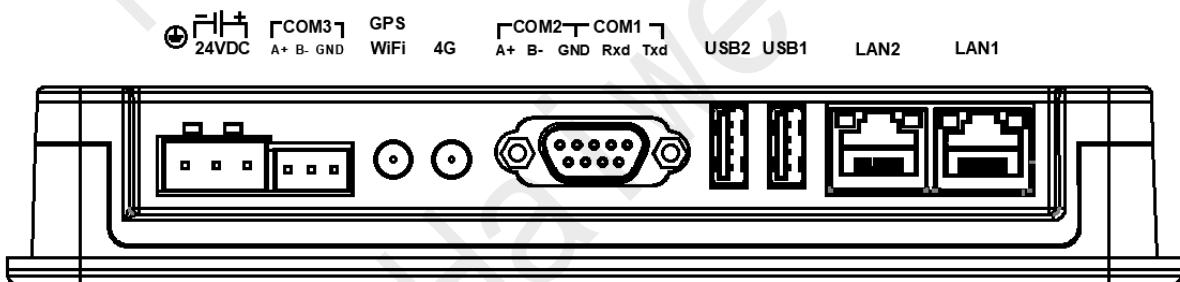

Figure15 HMI A7 Pro Common Interface

### ③HMI A10/A10-G/A10-W/A10-GP/A10-GW/A10-E/A10-EW

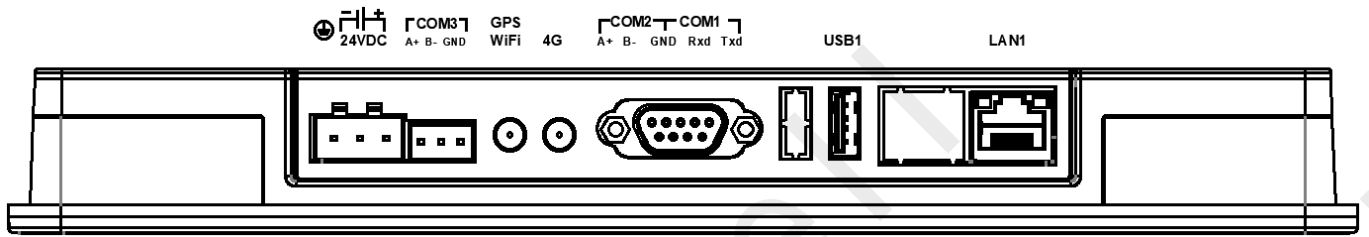

Figure16 HMI A10 Common Interface

### ④HMI A10 Pro/A10 Pro-G/A10 Pro-W/A10 Pro-GP/A10 Pro-GW/A10 Pro-E/A10 Pro-EW

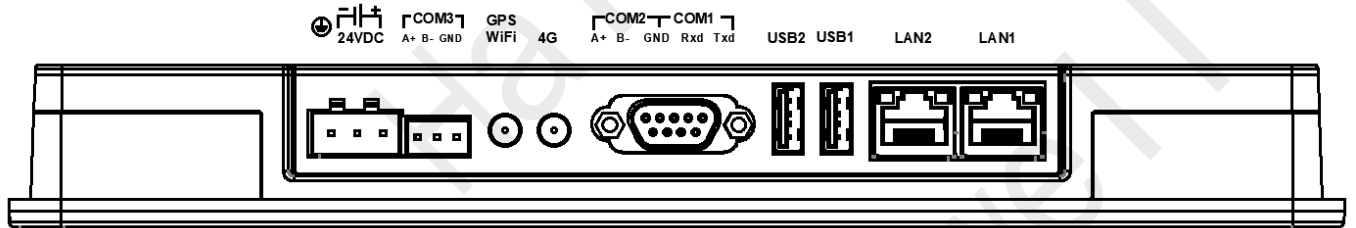

Figure17 HMI A10 Pro Common Interface

### ⑤HMI A15/A15-G/A15-W/A15-GP/A15-GW/A15-E/A15-EW/A15 Pro/A15 Pro-G/A15 Pro-W/A15 Pro-GP/A15 Pro-GW/A15 Pro-E/A15 Pro-EW

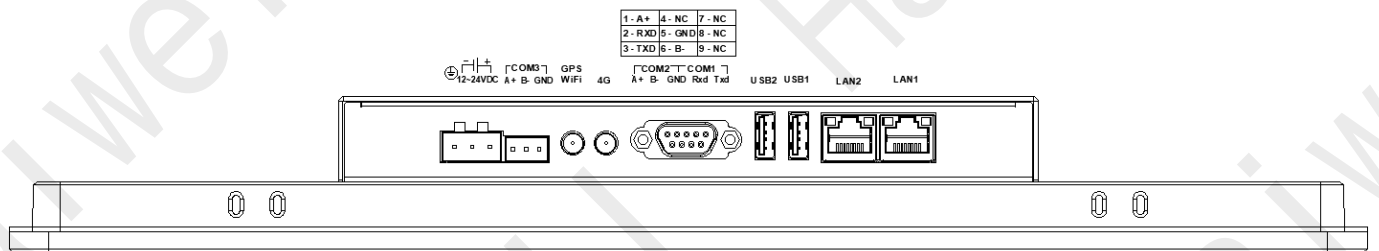

Figure 18 HMI A15/A15 Pro Common Interface

## 4.2 Definition of Communication Interface

Table1 Definition of Nine Pin Serial Port Pins (A7/A10/A15 Series)

COM1/COM2 Definition of nine pin serial port pins			
	Pin number	Definition	Pin description
	1	COM2:A+	RS485 communication "A+"
	2	COM1:RXD	RS232 communication receives data
	3	COM1:TXD	RS232 communication sends data
	4	NC	Null signal
	5	COM1:GND	Signal ground wire
	6	COM2:B-	RS485 communication "B-"
	7	NC	Null signal
	8	NC	Null signal
	9	NC	Null signal

Table2 Definition of COM3 Serial Port Pins (A7/A10/A15 Series)

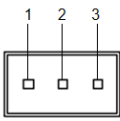
COM3 RS485 Pin Definition			
	Pin number	Definition	Pin description
	1	COM3:A+	RS485 communication "A+"
	2	COM3:B-	RS485 communication "B-"
	3	COM3:GND	Signal ground wire

## 5. HMI Electrical Connection

### 5.1 Power Connection

The HMI power interface is located on the leftmost side of the bottom of the device. The "24V+" of the switch power supply is connected to the "24V+" port of the device, and the "24V -" (0V) of the switch power supply is connected to the "24V -" port of the device. If in order to better protect the equipment and reduce electromagnetic interference, the HMI can be grounded and connected to the "GND" port of the device

In addition, the A series 15 inch has a 12V power supply port, and it is recommended to use 24V voltage. For specific interface definitions, please refer to 4. Product Interface -4.1 Interface Diagram ⑤.

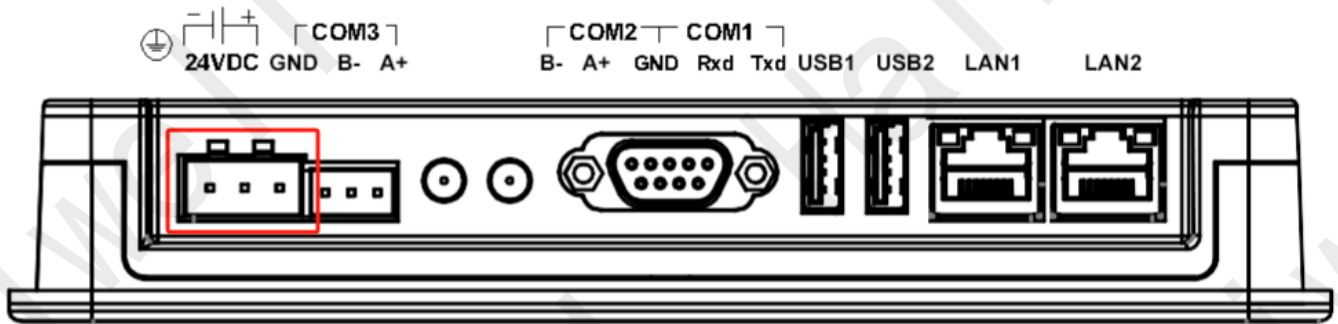

Figure19 Power Supply Terminal

### 5.2 Ethernet Connection

The HMI Ethernet LAN port is located on the far right side of the bottom of the device and is mainly used to connect the PC end with the HMI network cable, achieve communication between the HMI and PC ends, and complete operations such as uploading and downloading projects. The LAN port can also be connected to the lower computer for communication.

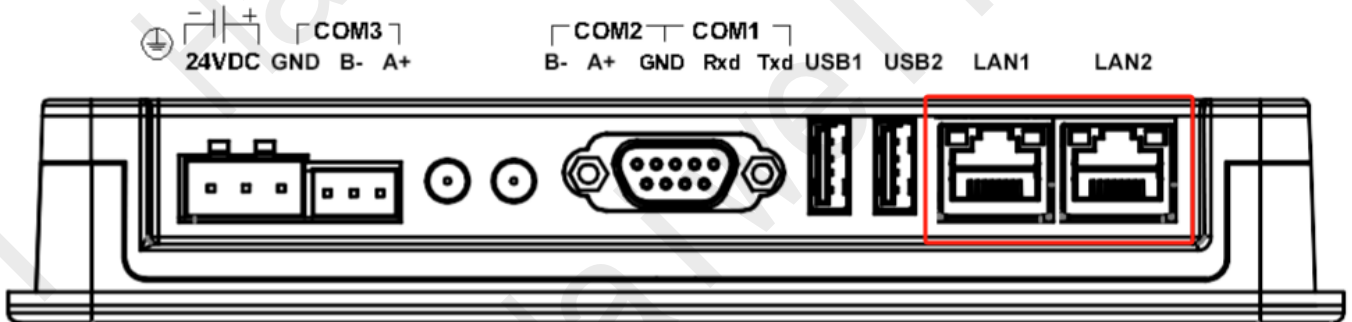

Figure20 Ethernet Port

## 5.3 Serial Connection

The HMI serial port is divided into DB9 interface and RS485 interface, which can support RS232/RS485 communication simultaneously.

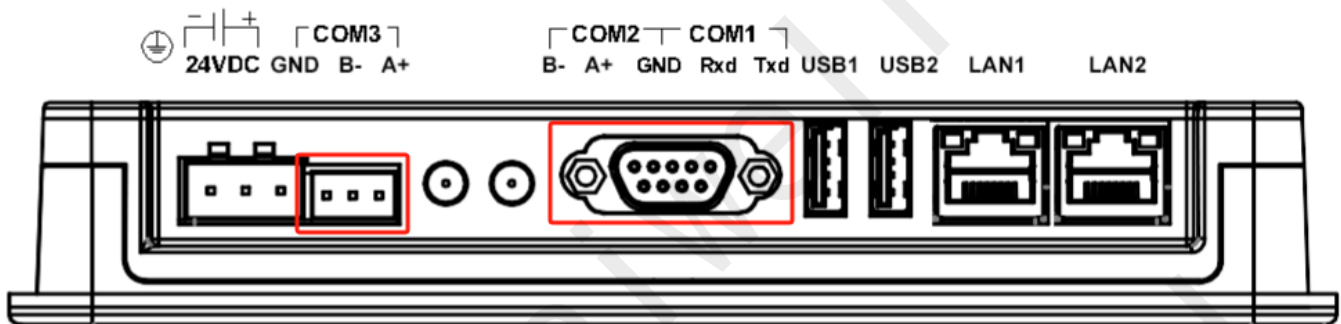

Figure21 Serial Communication Interface

## IV. HMI Installment and Use

### 1. Panel Installation

#### Step 1: Prepare to install the panel

1. Determine the opening size: Determine the opening size on the panel based on the HMI size and installation instructions.
2. Open holes: Use proper tools to open holes on the installation panel. Make sure the size and shape of the openings match the HMI's mounting holes.

#### Step 2: Install HMI

1. Align the HMI with the opening: Align the HMI with the opening on the panel, ensuring that the front of the HMI faces outward and the back faces inward.
2. Gently push in: Slowly and evenly push the HMI into the opening until the edge of the HMI is flush with the panel.

#### Step 3: Fix HMI

1. Find the buckle: There are 4 buckles on the side of the HMI.
2. Locking buckles: Gently press each buckle with your hand to secure it to the edge of the installation panel. Ensure that each buckle is securely fixed to the panel to prevent the HMI from loosening or falling off.

#### Matters needing attention:

- ① The installation direction must be in accordance with the instructions in this manual, and the wiring must strictly follow the direction marked on the terminal, otherwise it may cause product failure or burning.
- ② The product and other bottom components must maintain sufficient space to avoid equipment damage caused by poor heat dissipation.

### 2. Settlement Installation

#### Step 1: Assemble the Double-Layer Frame

1. Align the through-holes of the mounting iron parts with the studs on the panel. Use a screwdriver to tighten the screws in a diagonal sequence (top-left → bottom-right → top-right → bottom-left).

2. Ensure the frame is stable without shaking and the surface is flat without protrusions.

### **Step 2: Embed the HMI Device**

1. Place the HMI face up and horizontally insert it into the panel opening. Gently push until it is fully embedded.

2. Check that the device surface is flush with the panel and there are no gaps around the edges.

### **Step 3: Secure the Device Clips**

1. Insert the 4 fixing clips into the left and right hanging holes on the machine body. Use a screwdriver to tighten them evenly.

2. Ensure the screws press against the mounting iron parts with moderate tightness, and the device does not shift.

### **Step 4: Apply the Custom Face Sticker**

1. Clean the panel surface, peel off the back adhesive of the face sticker, and align it with the opening position. Apply it smoothly.

2. Press to remove air bubbles, adjust until the display area is fully exposed, and ensure no edges are curled up.

#### **Matters needing attention:**

- ① Design the opening panel and mounting iron parts according to the dimensional drawings provided in the product manual, with a material thickness between 1mm and 2mm.

- ② For Pro model installations, ensure the custom face sticker has corresponding openings.

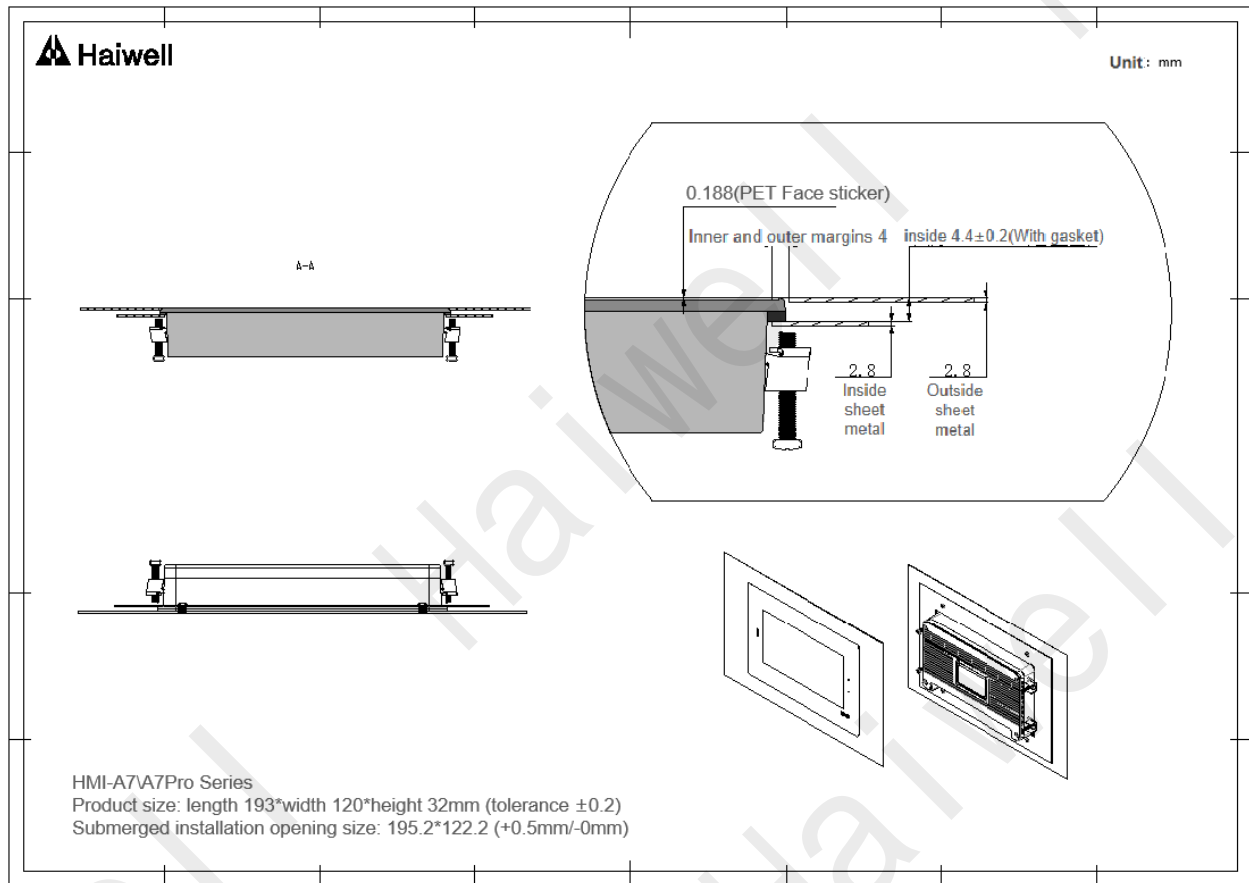

Figure22 HMI A7/A7 Pro Settlement Installation

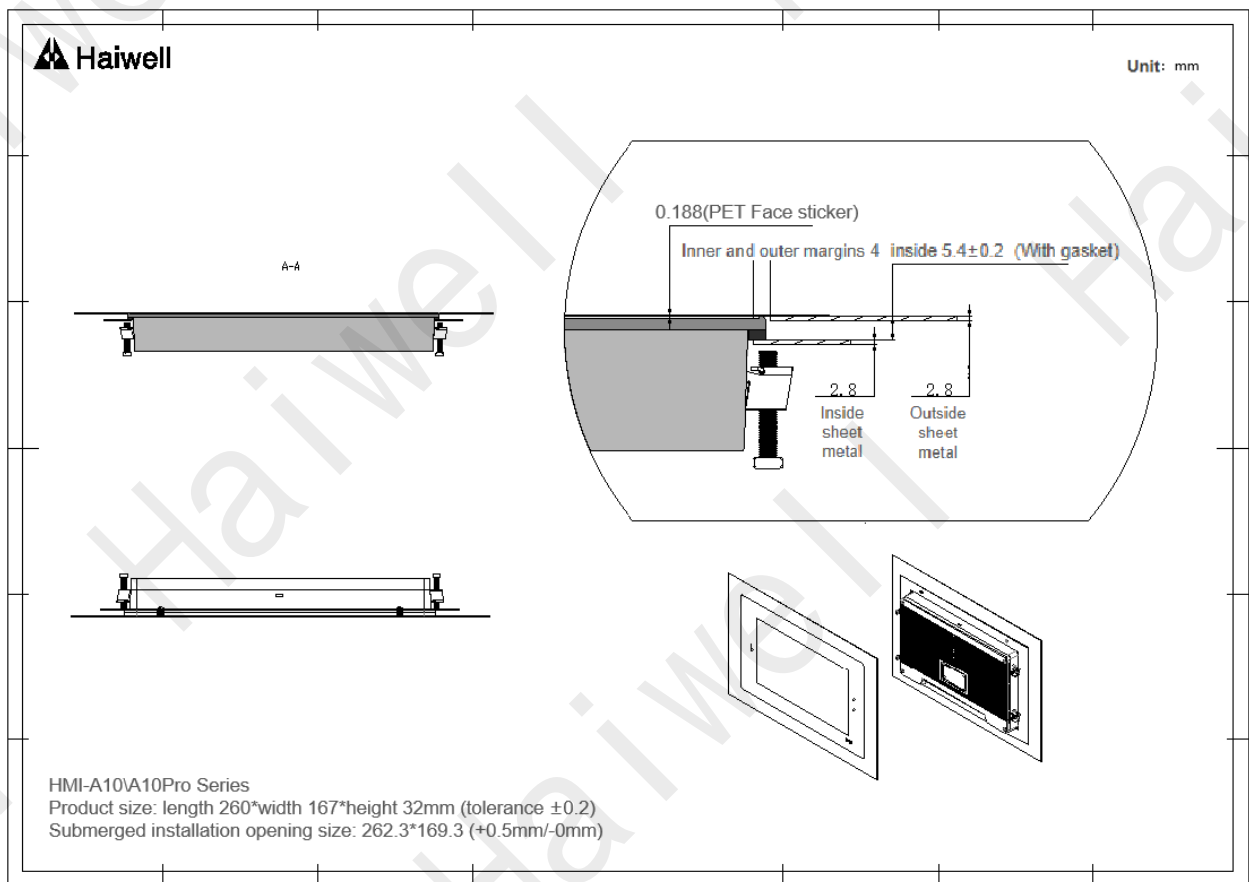

Figure23 HMI A10/A10 Pro Settlement Installation

### 3. Installation of External 4G Card

**Step 1:** The installation position of the external 4G card on the HMI is on the back of the HMI, and there is a hole on the right side of the back panel that can be opened.



Figure24 HMI 4G Card Backplane

**Step 2:** After removing the back cover, press the card slot downwards to open it. After opening, insert the 4G card and then press the card slot upwards to lock it.



Figure25 HMI Installation of 4G Card

**Note:** After inserting the 4G card, you need to restart the HMI to correctly recognize the SIM card.

## 4. Antenna Installation

Haiwell HMI can be equipped with 4G/WIFI/ Satellite positioning function. To obtain the best signal strength, please lead the antenna out of the control cabinet. After the antenna is led out from the HMI, it should be routed on the cabinet door, and the antenna should avoid the power supply line. The antenna is led out in a straight line through the opening and closing edge of the cabinet door to the top opening of the cabinet, as shown in Figure26:

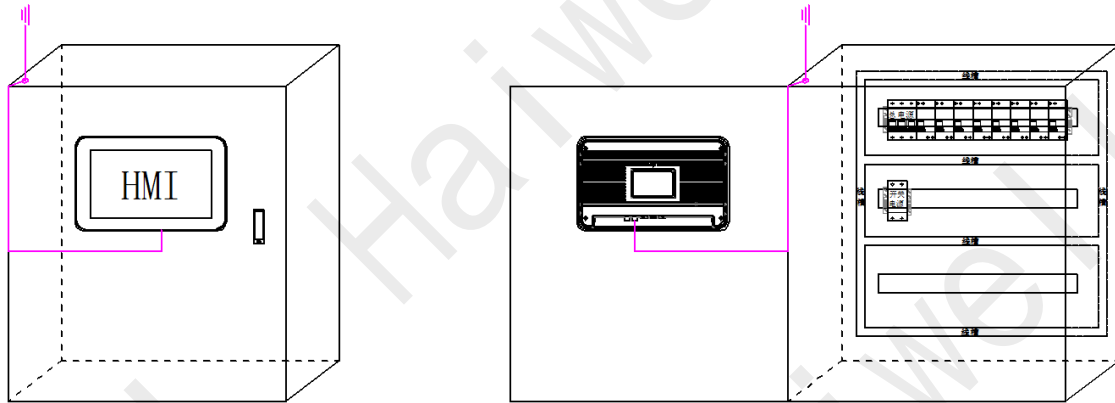

Figure26 HMI Antenna Installation Diagram

## V. HMI Settings

### 1. HMI Supporting Software

Haiwell HMI needs to be used in conjunction with Haiwell SCADA editing software. Please download it from the official website of [Haiwell Software Download Center](#).

### 2. HMI Background Settings

#### 2.1 Background Setting Entry Method

Long press the upper right corner of the HMI screen (for about 5 seconds), and when you hear the device make a 'beep' sound, you can release it. At this time, the HMI enters the background settings interface.



Figure27 Enter the Background Settings

## 2.2 Project Settings

The project settings mainly support downloading generated project operation files through USB flash drives, as well as accessing project screens of other smart connected devices in the local area network through device IP addresses.

### Network Connection Project:

Enter the HMI background settings interface, click on **【Project Settings】**, click on **【Connect Network Project】**, and enter the IP address of the HMI that needs to be connected to the same local area network to achieve remote access between HMIs.

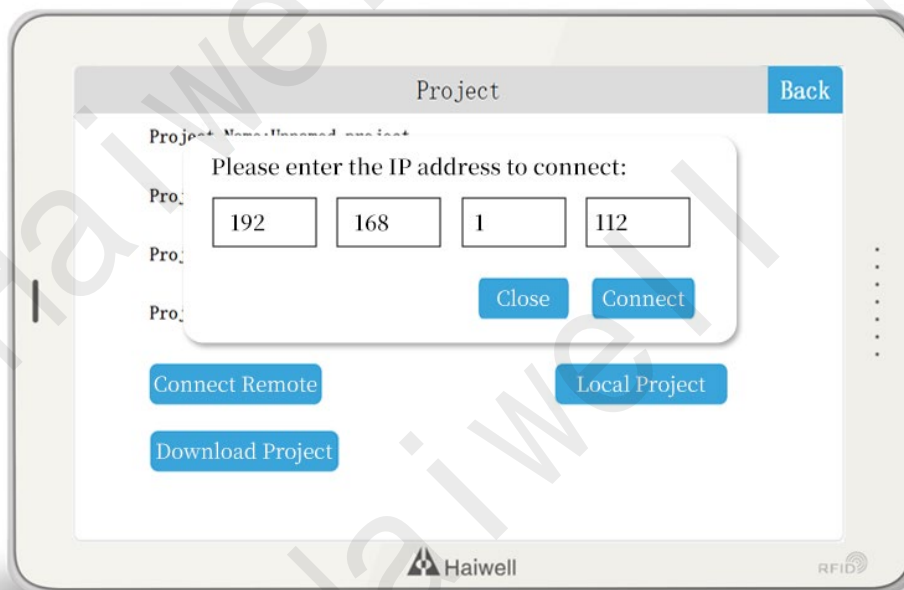

Figure28 Connect Network Project

### Connect Local Project:

When the HMI is connected to the online project and accessing other HMI project, if you want to return to the original HMI to run the project, you can click on **【Run Local Project】**

### Download Project:

#### (1) Generate USB Drive Running Files

Step 1: Create a project, click on **【Project】** in the Scada menu bar, expand the tab, and click on **【Generate USB Run File...】** ;

Step 2: Enter the compilation interface, set the appropriate output path after compilation, and click **【Save】** ;

Step 3: After successfully saving the file, the system will pop up a prompt box indicating successful saving. Click **【OK】** to proceed.

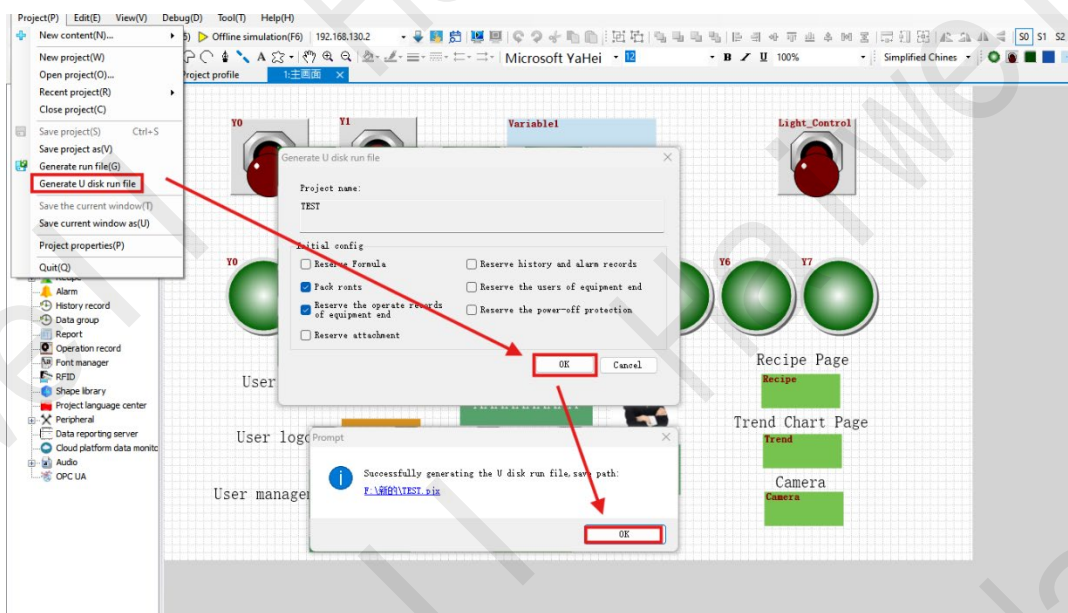

Figure29 Generate USB Drive Running Files

## (2) USB Download Project

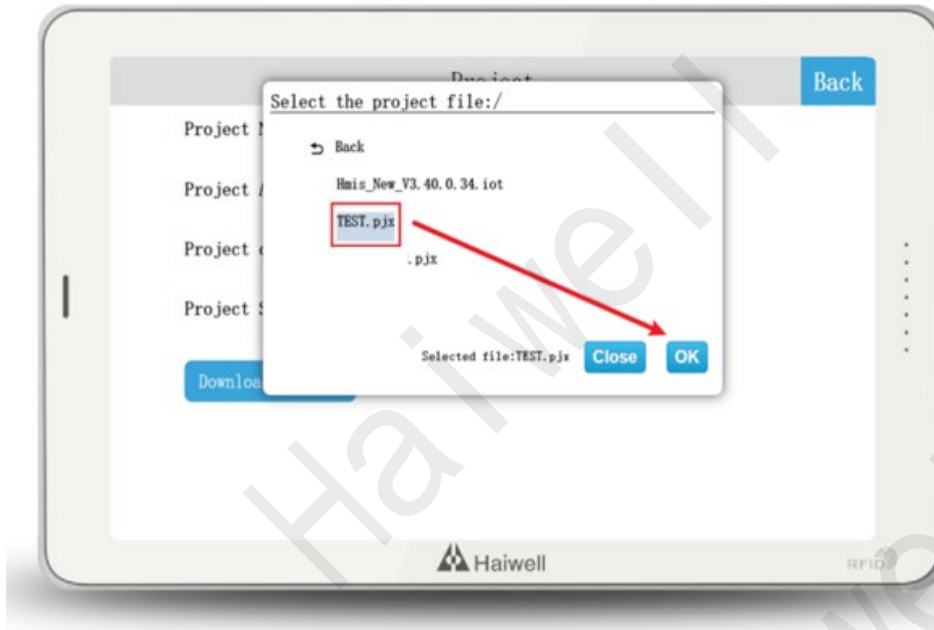

Figure30 USB Download Project

## 2.3 Local Settings

The main setting of this machine is to set the basic functions and parameters of the HMI.

### (1) Local Settings

#### ① Set Terminal Name

Enter the HMI background settings interface, click on **【Local Settings】**, In the **【Local Settings】** interface, you can see the **【Terminal Name】**. Click on **【Settings】**, enter the new terminal name, and press Enter on the keyboard. Terminal Name: Device Name.

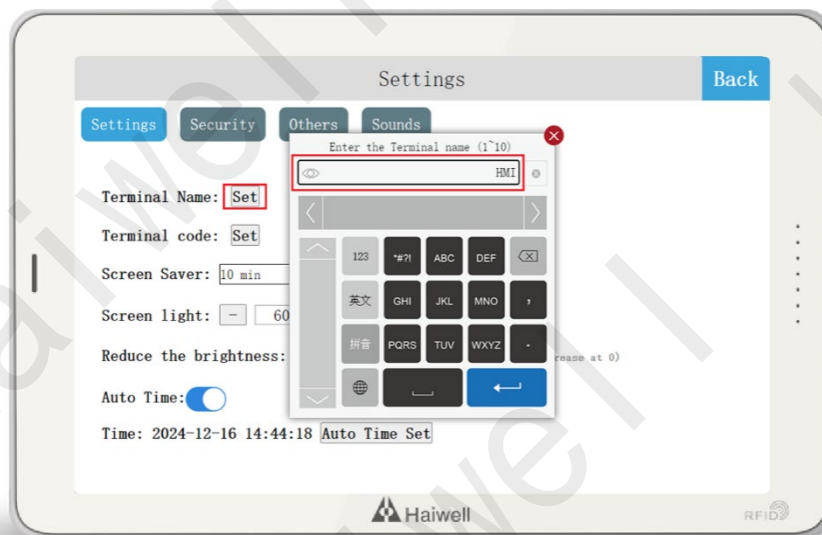

Figure31 Setting Terminal Name

**Note:** The length of the terminal name is 1-10 digits.

### ② Set Terminal Number

Enter the HMI backend settings interface, click on **【Local Settings】**, and in the **【Local Settings】** interface, you can see the **【Terminal Number】**. Click on **【Settings】**, enter the new terminal number, and press Enter on the keyboard. Terminal Number: Device Number.

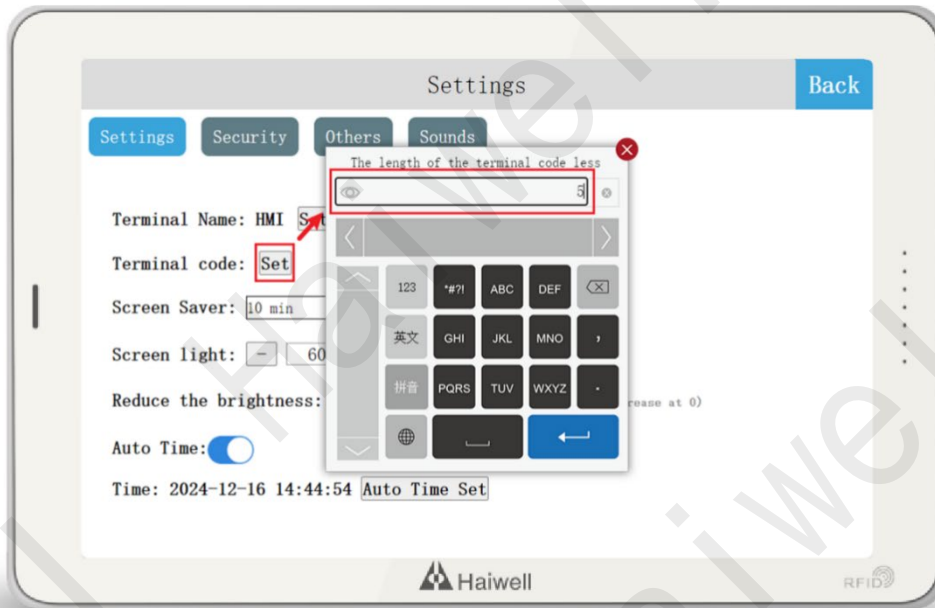

Figure32 Set Terminal Number

**Note:** The length of the terminal number is 0-10 digits.

### ③ Set Network Timing

Enter the HMI background settings interface, click on **【Local Settings】**, open network timing in the **【Local Settings】** interface, and then click on automatic timing settings. The current time will automatically correspond to the network time.

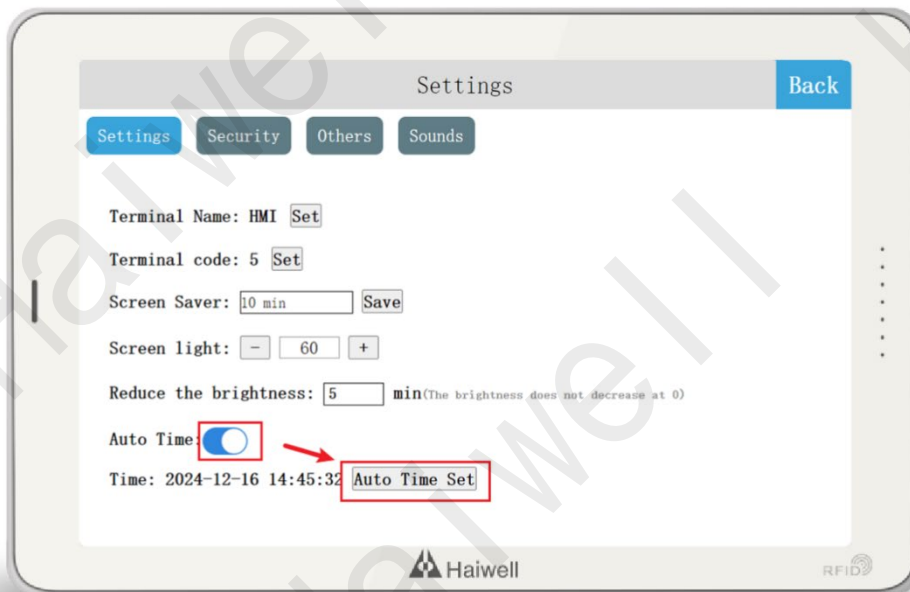

Figure33 Setting Network Timing 1

Enter the HMI background settings interface, click on **【Local Settings】**, turn off network timing in the **【Local Settings】** interface, and then click on Change Time to manually enter the set time. After entering, click 'OK'. If Click 'Cancel' and then the content just entered will not be saved.

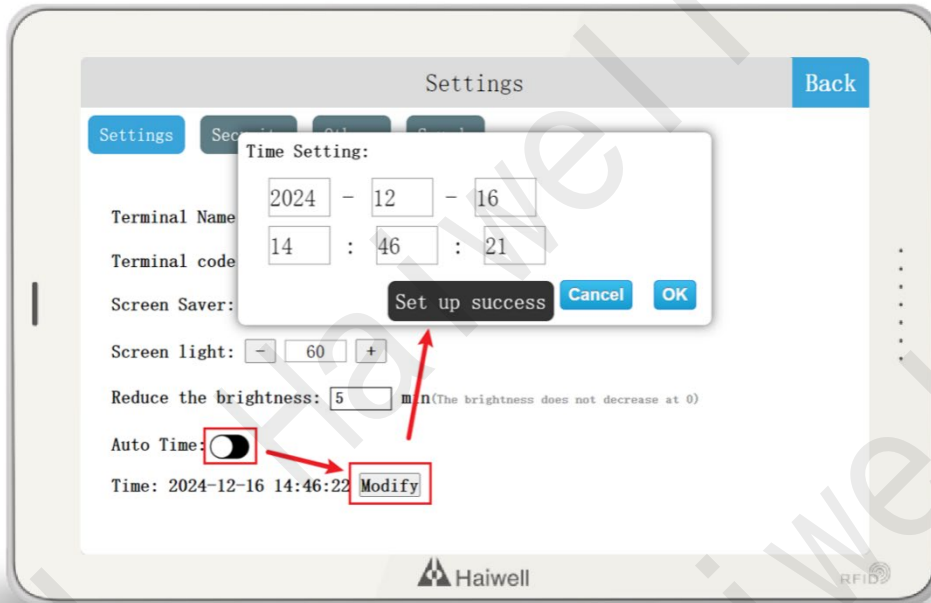

Figure34 Set network Synchronization 2

## (2) Safety Setting

### ① Download Project Password

Enter the HMI background settings interface, click on **【Local Settings】**, open the **【Download Project Password】** function in the **【Security Settings】** interface, set the HMI download project password. After successful setting, users need to verify the password to download projects and update firmware, otherwise they cannot do related operations.

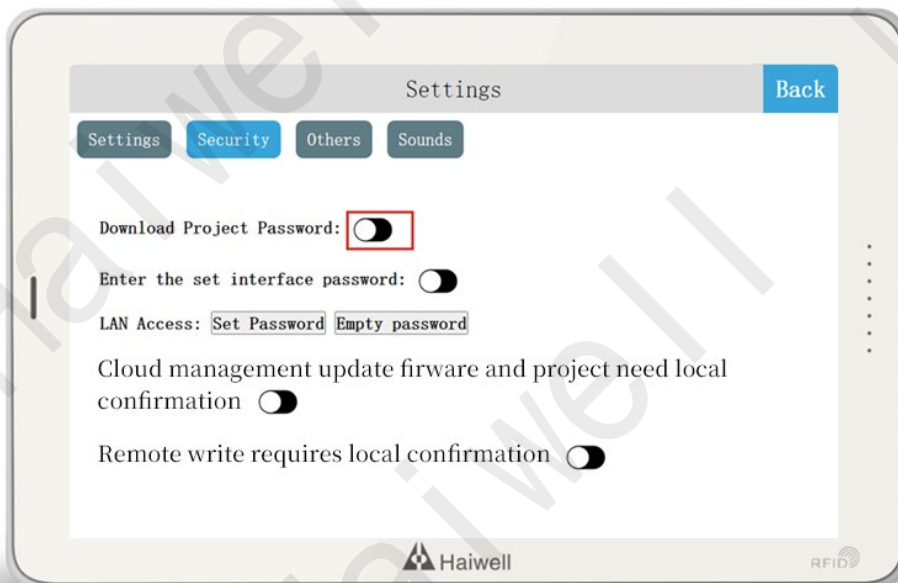

Figure35 Download Project Password

**Note:** The password for downloading the project should be carefully set. If you forget the password, you need to reset it to the factory settings.

## ② Enter Background Password

Adding password verification to the background can prevent security risks and economic losses caused by unrelated personnel's misoperation. The specific steps are as follows:

Step 1: Enter the HMI background settings interface and click on **【Local Settings】** ;

Step 2: Open the **【Enter Background Password】** function in the **【Security Settings】** interface;

Step 3: Set the password to enter the background. After successful setting, the user needs to verify the password to enter the background settings.

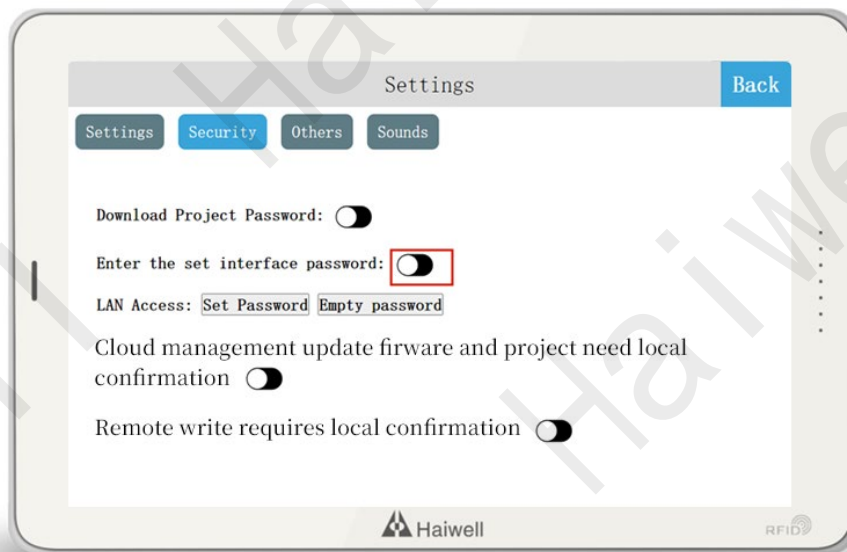

Figure36 Set Password to Enter the Background

**Note:** When setting the password to enter the background, caution should be taken. If you forget the password, you need to contact technicians in Haiwell to clear it.

## ③ LAN Access

Enter the HMI background settings interface, click on **【Local Settings】** , switch to the **【Security Settings】** interface, and enable LAN access by default. Users can click on **【Set Password】** as needed, enter the password they want to set, click Enter, enter the password they just entered again, and click Enter to save the LAN access password they just set. To access the device through LAN, mobile app, cloud website, TVBOX, etc., users must enter the correct LAN access password.



Figure37 Set LAN Access Password

Click to clear password, and a message will pop up saying "Setting successful, it is recommended to set a password to improve security". This means clearing the previously set LAN password, and users can access the HMI through the LAN (without entering a password).

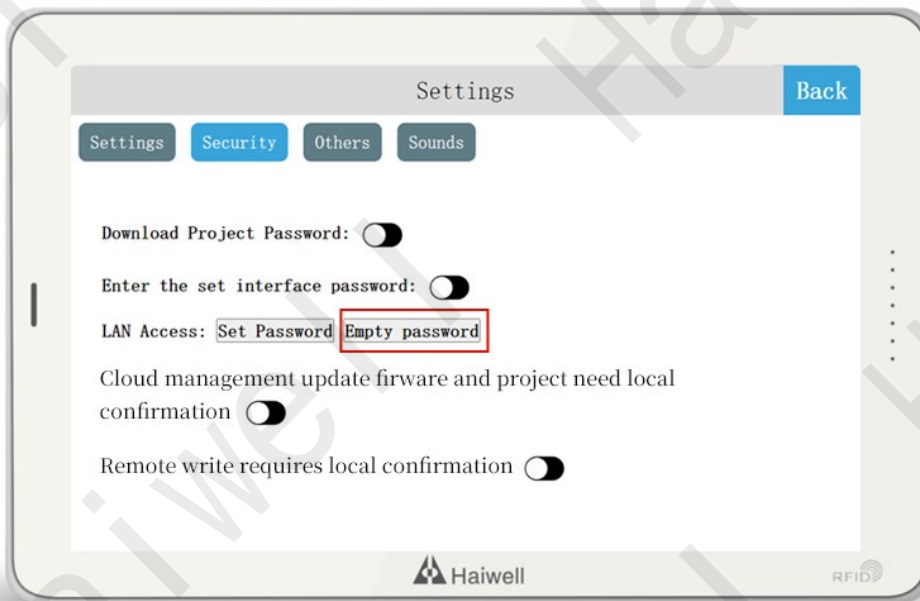

Figure38 Clear LAN Access Password

④ **Cloud Management Firmware and Project Updates Require Local Confirmation (default off)**

After enabling this feature, when remotely updating firmware or project, it is necessary to apply for local confirmation.

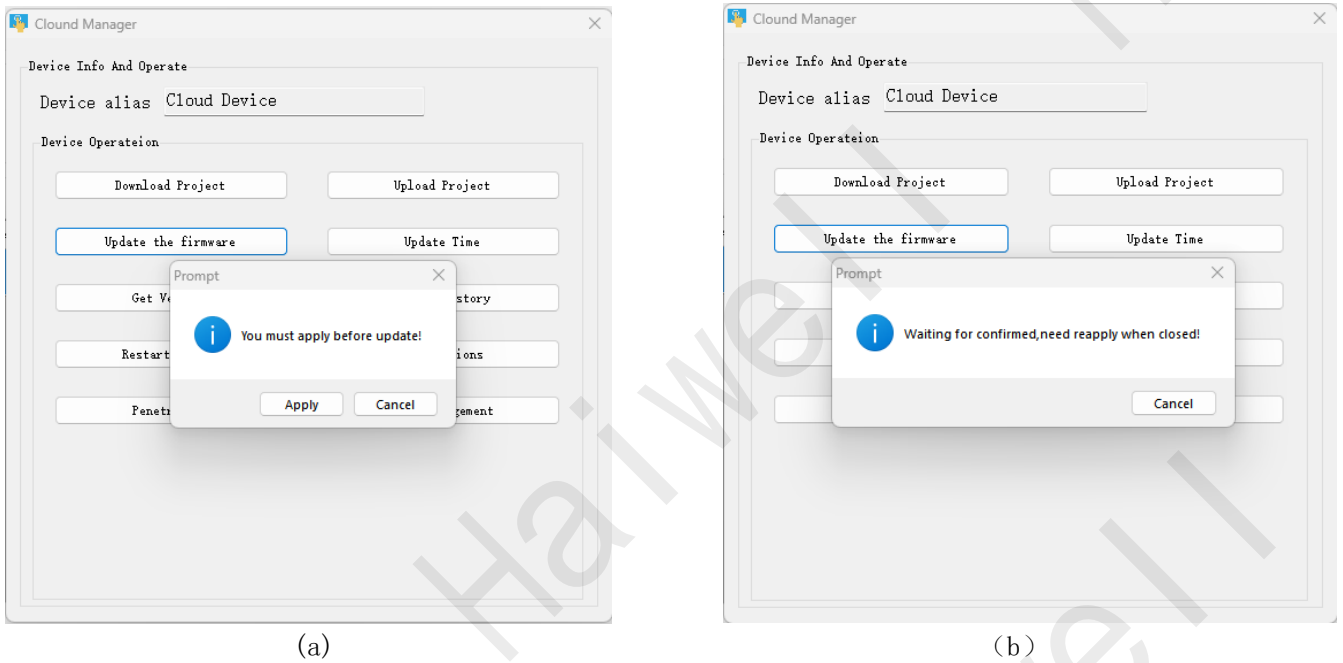

Figure39 Cloud Management Firmware Update Application

After the application is successful, the local device will receive the corresponding message and pop up the following screen. If the update is successful after approval, the device will automatically restart (default rejection after 120 seconds).

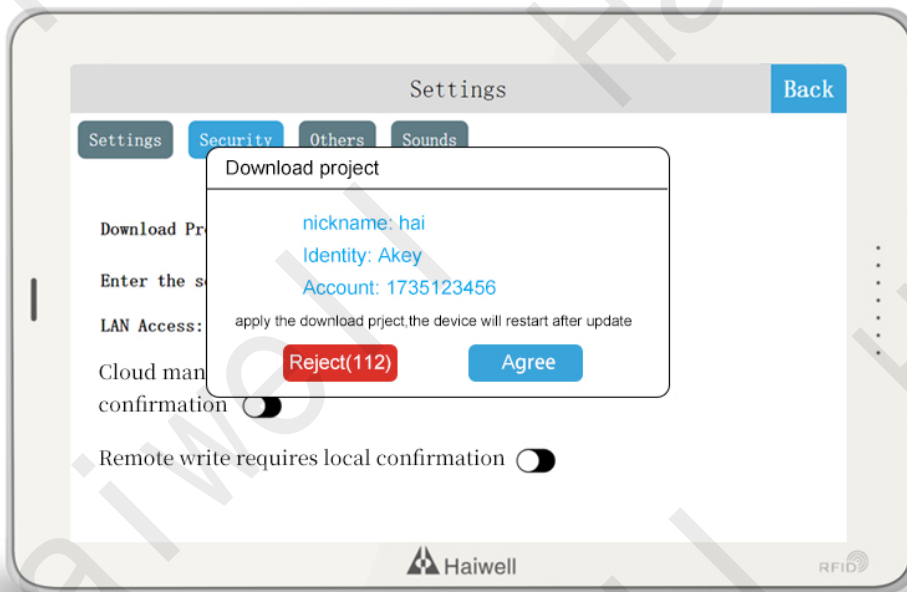

Figure40 HMI Remote Download Project Prompt Box

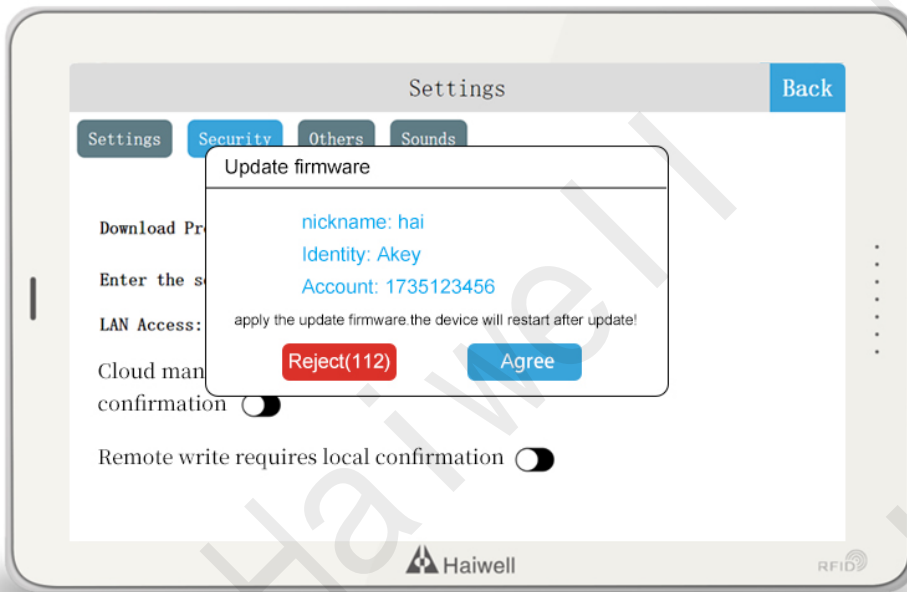

Figure41 HMI Remote Firmware Update Prompt Box

⑤ Remote Writing Requires Local Confirmation (default off)

After enabling this feature, when using cloud apps or cloud websites for remote operations, it is necessary to apply for local confirmation.

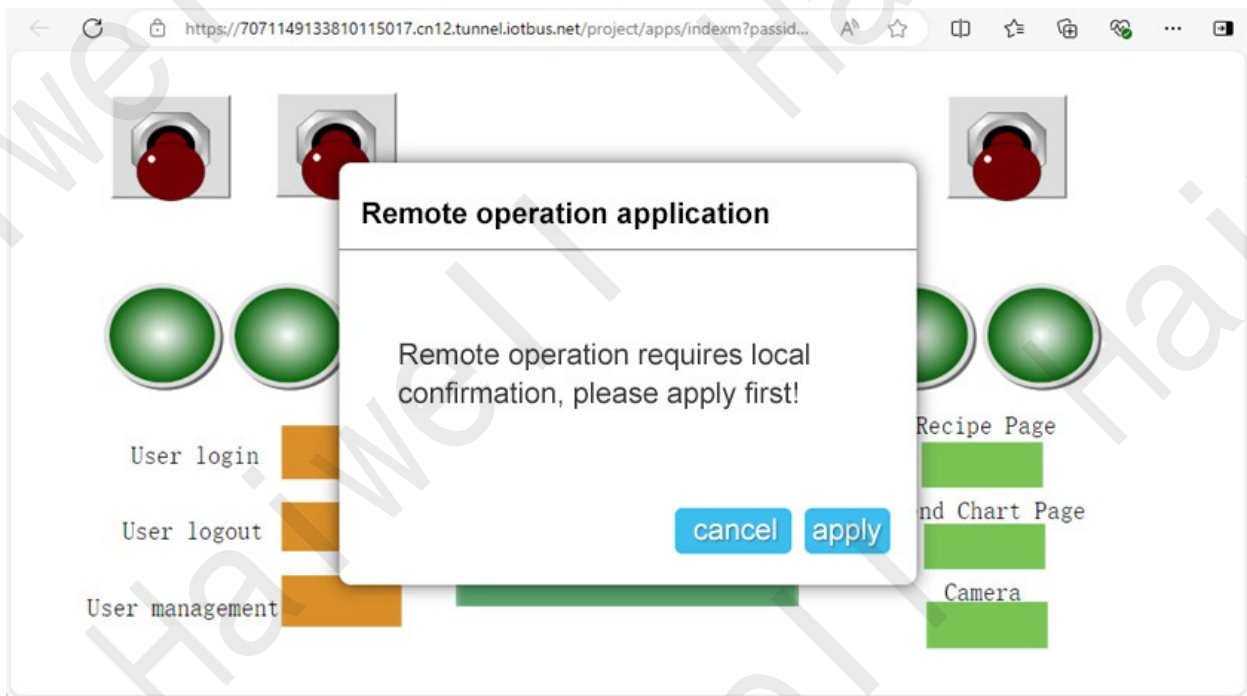

Figure42 HMI Remote Firmware Update Prompt Box

After receiving the application, the following screen will pop up locally. If approved, the device has remote write permission (default rejection after 120 seconds).

Figure43 HMI remote operation application prompt box

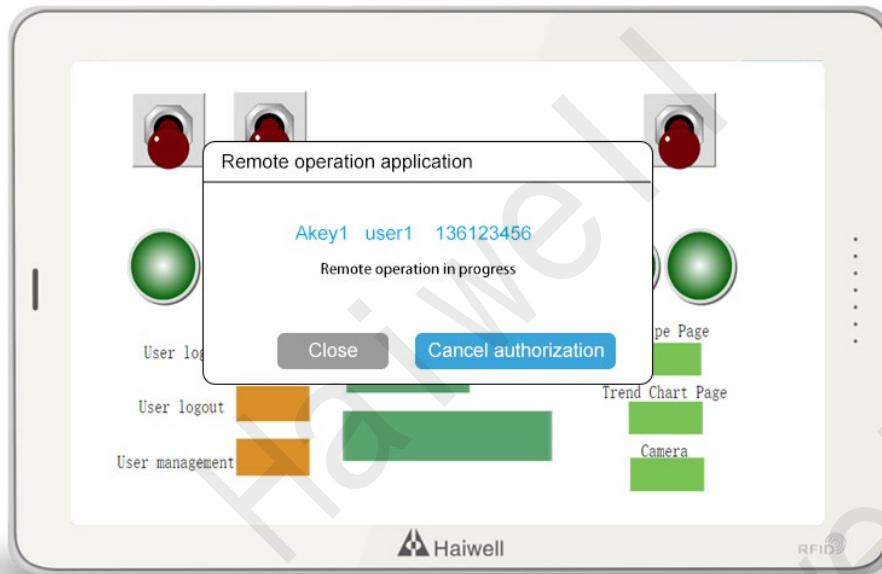

Figure44 HMI Remote Operation Authorization Application in Progress

When applying for other devices again, the following interface will pop up.

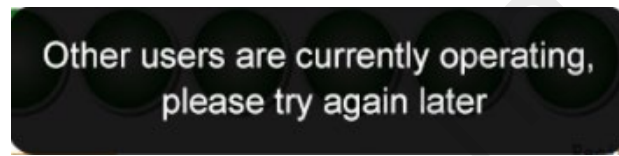

Figure45 HMI Prompt Box

An interactive identifier will appear in the lower left corner of the local device, which can be used to modify device permissions.



Figure46 HMI Interactive Identification

After cancel authorization, the remote device will pop up the following screen, and other remote devices can apply for operation at this time.

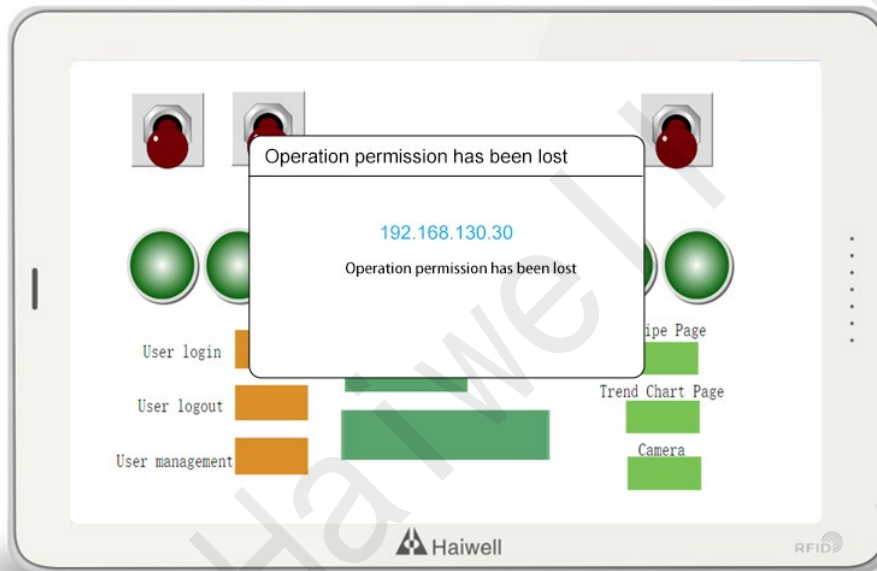

Figure47 HMI has Lost Operational Privileges

### (3) Other Settings

#### ① Set Cloud Online Detection Frequency

Enter the HMI background settings interface, click on **Local Settings**, switch to the **Other Settings** interface, click on **Settings** on **Set Cloud Online Detection Frequency**, and select the cloud online detection frequency we need.

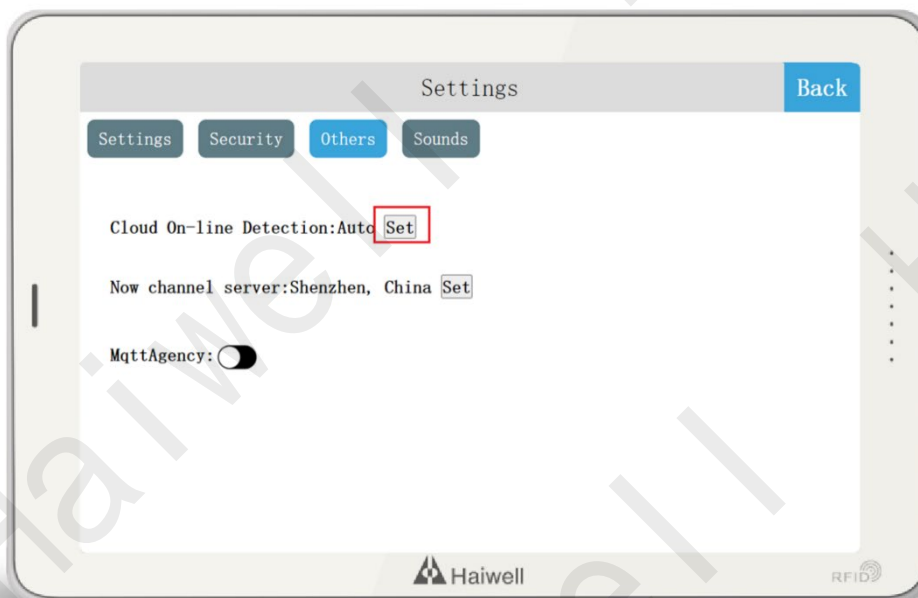

Figure48 Setting Cloud Online Detection Frequency

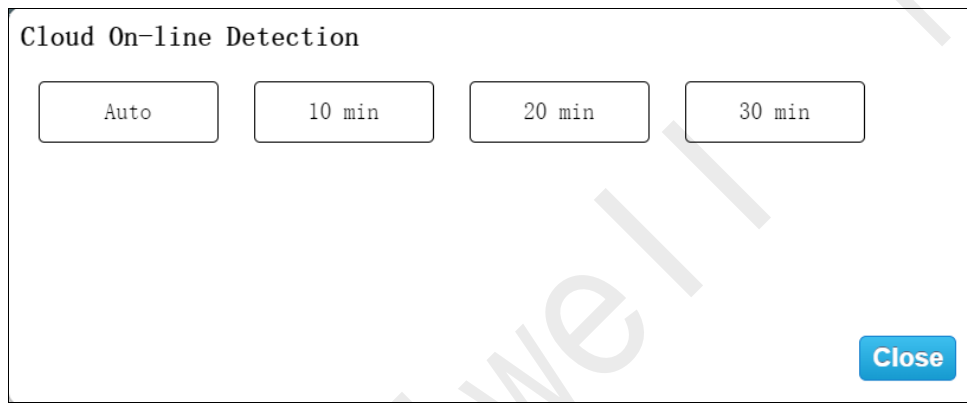

Figure49 Equipment Cloud Online Detection Frequency

## ② Set the Current Cloud Server

Enter the HMI background settings interface, click on【Local Settings】, switch to the【Other Settings】interface, click on 【Settings】 on the "Current Cloud Server", select the cloud server address we need, and the current cloud server will be displayed as the selected server address. Click on 【Auto Select】 to automatically select a relatively nearby cloud server address based on the IP address. Click 【Close】 to close the interface.



Figure50 Setting the Current Channel Server

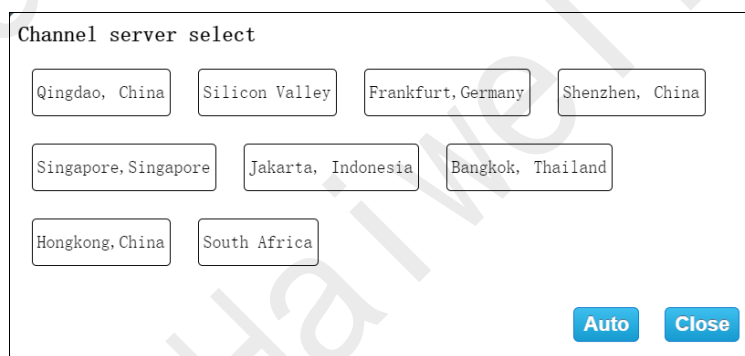

Figure51 Channel Server Selection

### ③ MQTT Proxy

Clicking on MQTT proxy can enable or disable MQTT proxy. Enabling MQTT proxy will use HMI as a small MQTT server, with the server address being the Ethernet IP address or WIFI IP address of the device. For specific usage of MQTT, please refer to the MQTT user manual. MQTT proxy is disabled by default and will remain on until manually disabled.

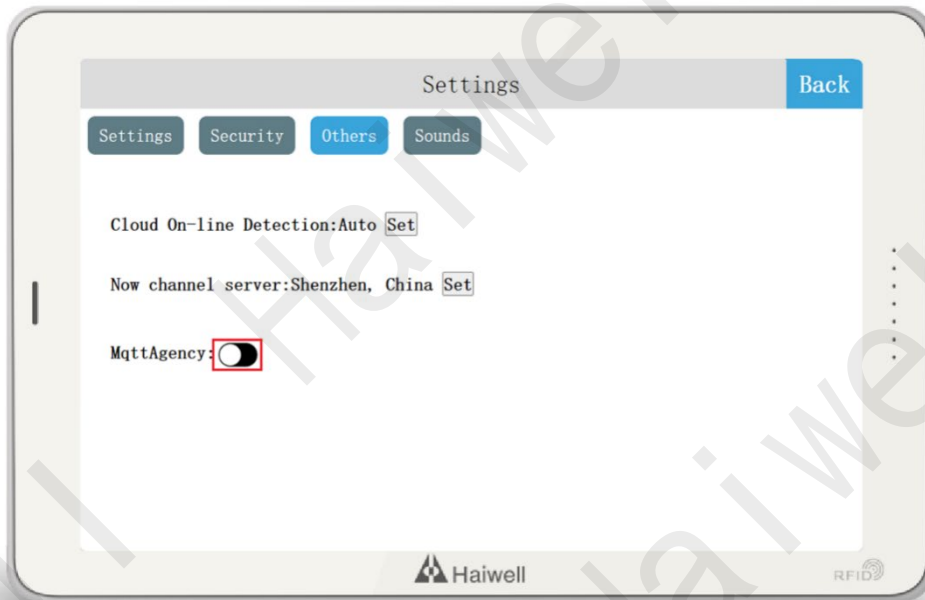

Figure52 MQTT Proxy

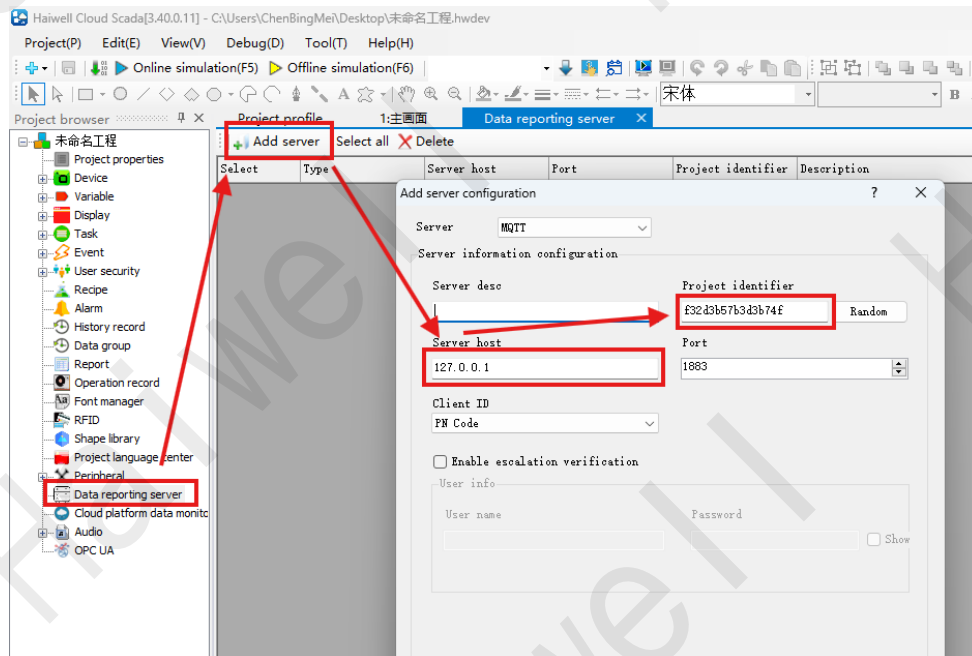

Figure53 Configuration Project Server Settings

#### (4) Sound Settings

Users can activate the "buzzer switch", "boot music", "power on text music" according to their needs, and also set the sound volume.

##### ① Buzzer Switch

Enter the HMI background settings interface, click on【Local Settings】, switch to the【Sound Settings】interface, turn on the "Buzzer Switch", and touch the device to emit a sound "beep";

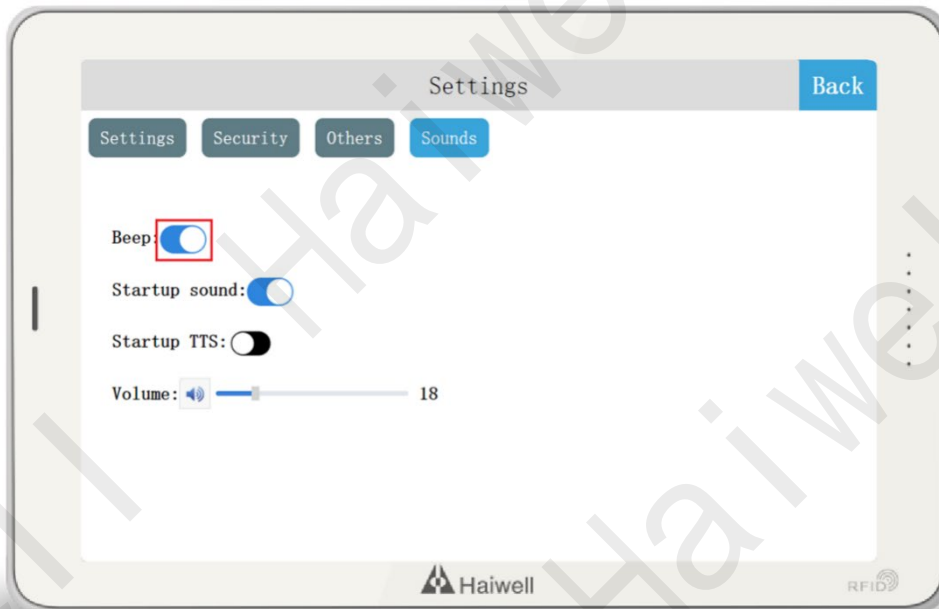

Figure54 Buzzer Switch

##### ② Boot Music

Enter the HMI background settings interface, click on【Local Settings】, switch to the【Sound Settings】interface, turn on the "Power on Music" switch, and when the device is turned on, the configured music will be played.



Figure55 Startup Sound

### Project Attribute Settings:



Open Haiwell SCADA (version 39.0 or above), double-click  **Project properties** to enter the project properties interface, click on **【Boot Setting】**, enable power on music, and set the power on music: you can set the last device used music; User can also choose "Customize", click  to import local audio, and customize the startup music settings. Users can choose whether to turn on "stop playing music when entering the interface" according to their needs.



Figure56 Custom Settings for Boot Music

When selecting "Factory", check "Clear device side custom music" to perform factory settings and clear existing custom music.



Figure57 Factory Settings for Boot Music

### Device Manager Settings:

Open Haiwell SCADA (version 39.0 or above), click  to enter the device manager interface, enter the IP address of the device to be accessed, click on **【Management】**, click on **【Boot Options】**, and click on **【Custom Power on Music】** to make the settings.

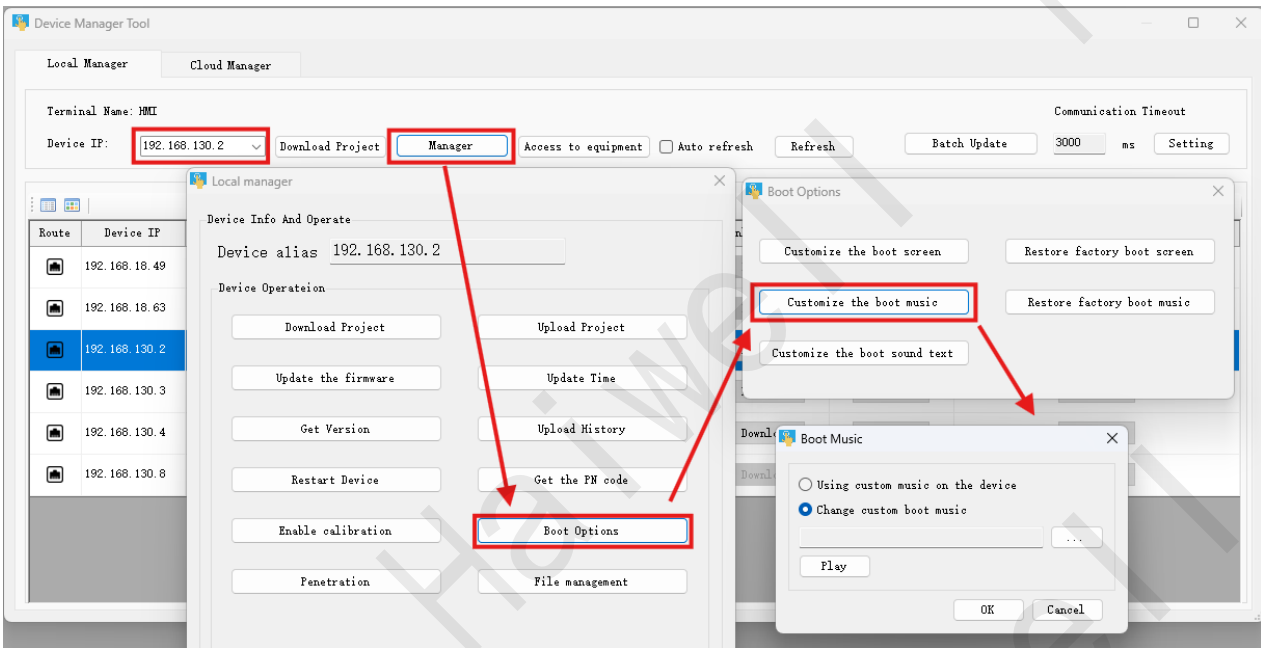

Figure58 Custom Boot Music

### ③ Startup Text Voice

Enter the HMI background settings interface, click on【Local Settings】, switch to the【Sound Settings】interface, turn on the "Startup Text Voice" switch, and when the device is turned on, it will broadcast the configured text content.



Figure59 Power on Text Voice

### Project Attribute Settings:

Open Haiwell SCADA (version 39.0 or above), double-click to enter the project properties interface, click on【Boot Setting】, enable text voice, and enter the corresponding text content to complete the settings.

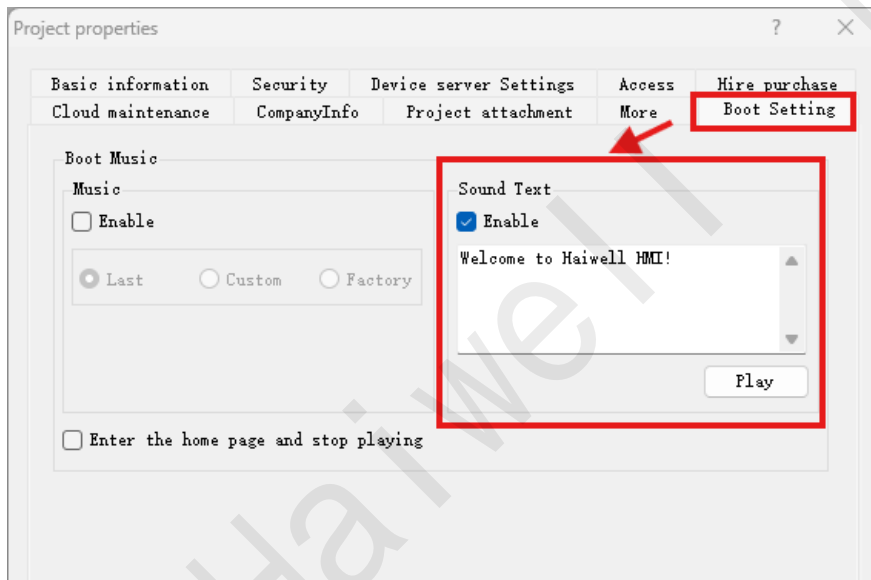



Figure60 Text and Voice Settings

### Device Manager Settings:

Open Haiwell SCADA (version 39.0 or above), click  to enter the device manager interface, enter the IP address of the device to be accessed, click on **【Management】**, click on **【Boot Options】**, and click on **【Custom Power on Voice Text】** to make the settings.

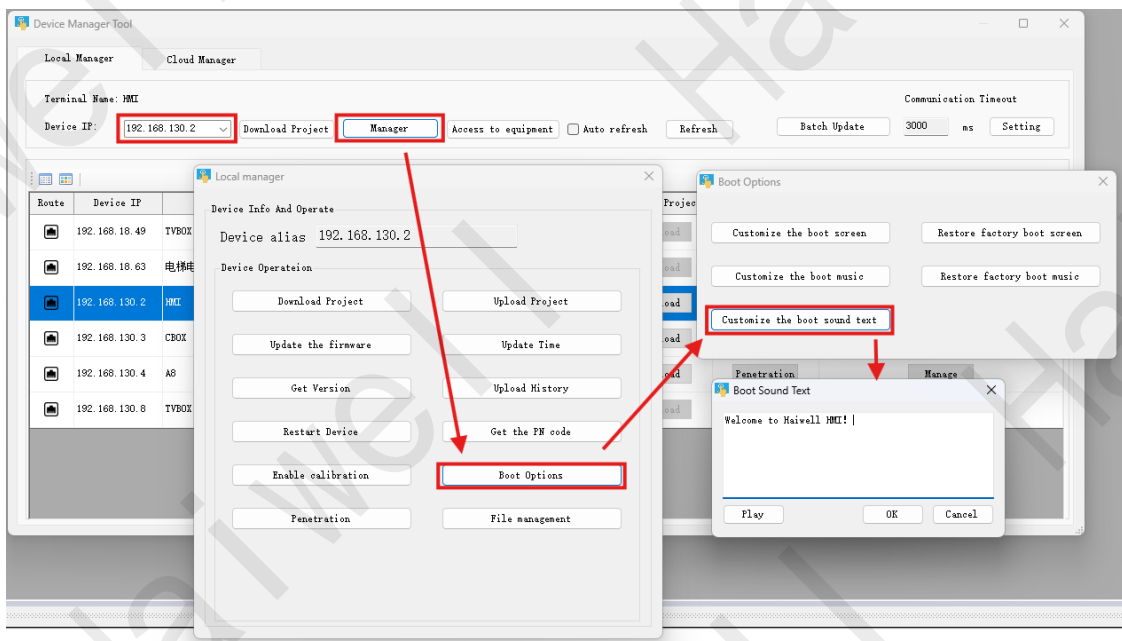

Figure61 Custom Power on Voice Text

## 2.4 System Information

### (1) Restart Device

The user enters the HMI background settings interface, clicks on **【System Information】**, and selects **【Restart Device】** to restart the HMI device.



Figure62 Restarting the Device

### (2) Firmware Update

Update the firmware on the USB drive, enter the HMI background settings, click on **【System Information】**, select **【Firmware Update】**, enter the firmware upgrade interface, select **【USB】**, choose the appropriate firmware update package, click **【OK】** to upgrade the firmware. After the upgrade is successful, the device will restart.

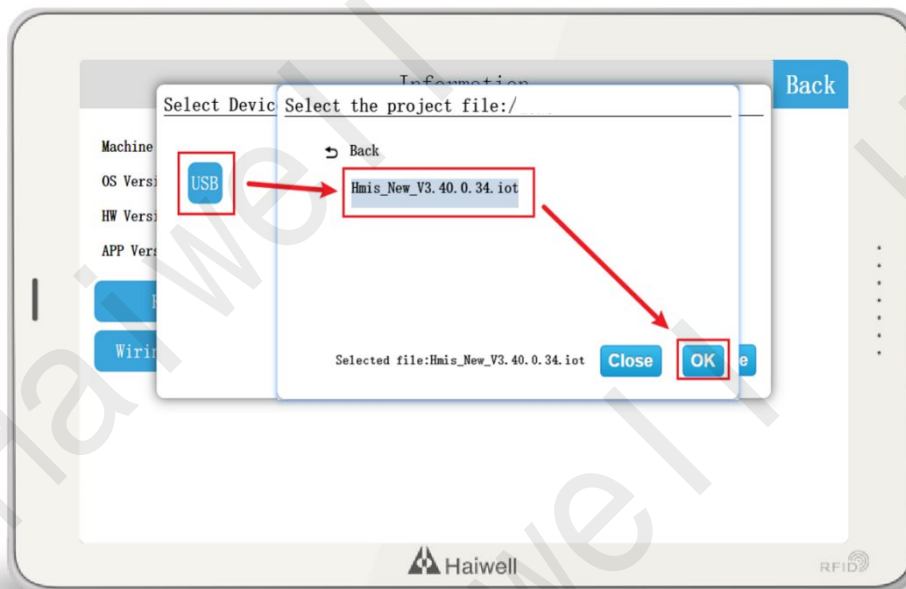

Figure63 Firmware Update

### (3) Start Touch Screen Calibration

Click on **【Enable Touch Screen Calibration】**, and a pop-up will appear saying **【Enabling Calibration will restart the device, do you want to restart calibration?】** Click 'Confirm' to perform touch screen

calibration.

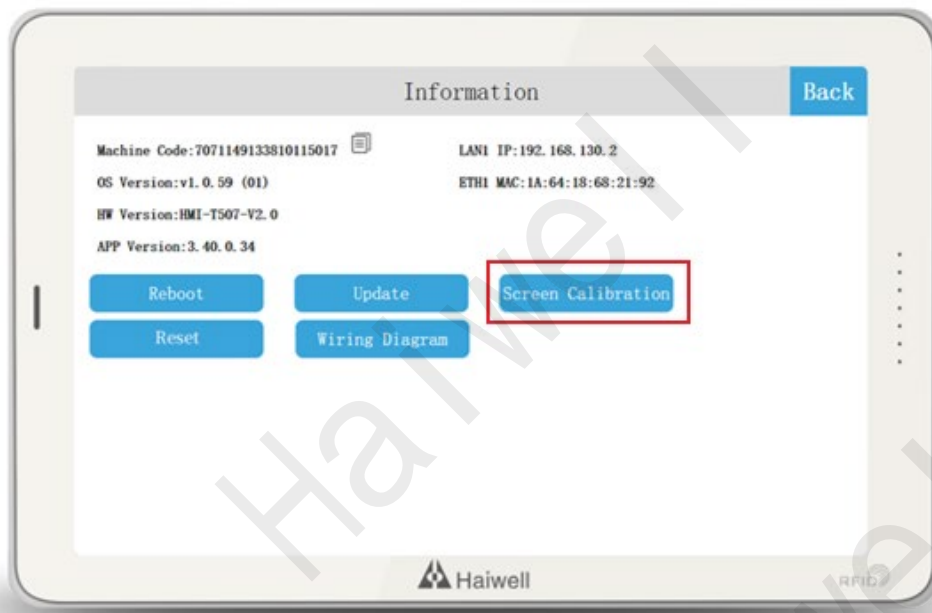

Figure64 Start Touch Screen Calibration

Please refer to section [VIII. HMI Calibration](#).

#### (4) Factory Reset

Click on **【Restore Factory Settings】** and a prompt box will pop up saying **【After restoring factory settings, all configuration information will be cleared. Do you want to restore it?】** Click 'Confirm' to restore factory settings.

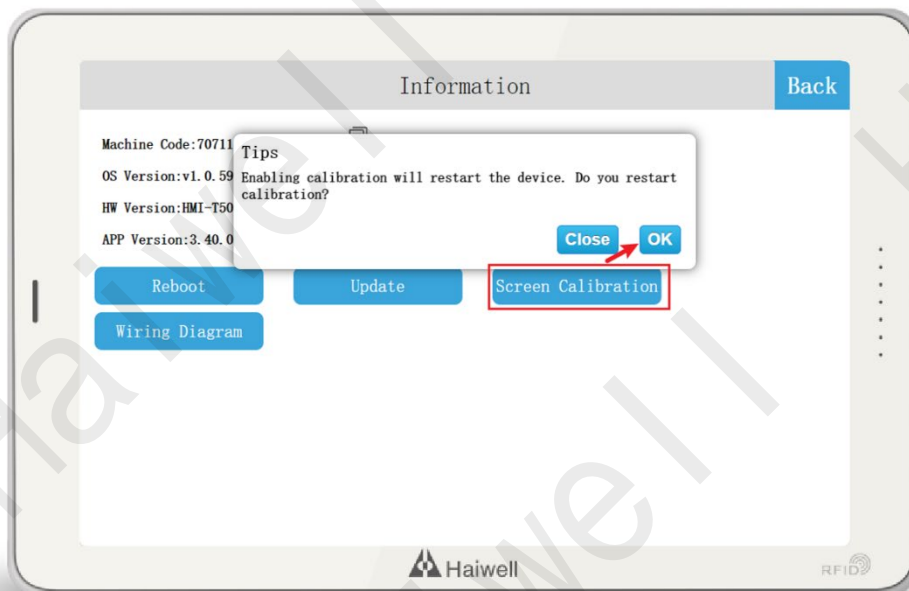

Figure65 Restoring Factory Settings

**Note: Restoring factory settings cannot recover cloud settings account binding information. Please delete the device on the cloud app/platform.**

### (5) Serial Port Wiring Diagram

Click on the **【Serial Port Wiring Diagram】** and a nine pin serial port COM1/COM2 pin definition will pop up.

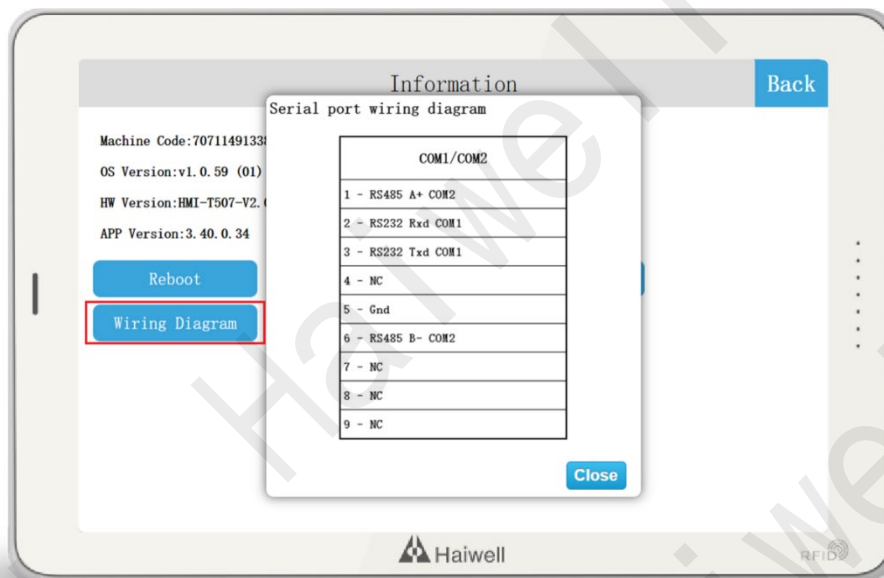

Figure66 Serial Port Wiring Diagram

## 2.5 Cloud Settings

Cloud settings are mainly used to bind devices to personal devices or enterprise devices. The premise of using this function is to ensure that devices can connect to the Internet normally.

### (1) Mobile Phone Cloud APP/ WeChat Applet Download

#### ① APP

Scan the QR code to obtain it directly



Figure67 Download the QR Code of Haiwell Cloud APP

#### ② WeChat Mini Program

Search Xiamen Haiwell on WeChat official account, click Send Message, select Hotspot - applet in the chat box, and you can directly enter Haiwell APP.

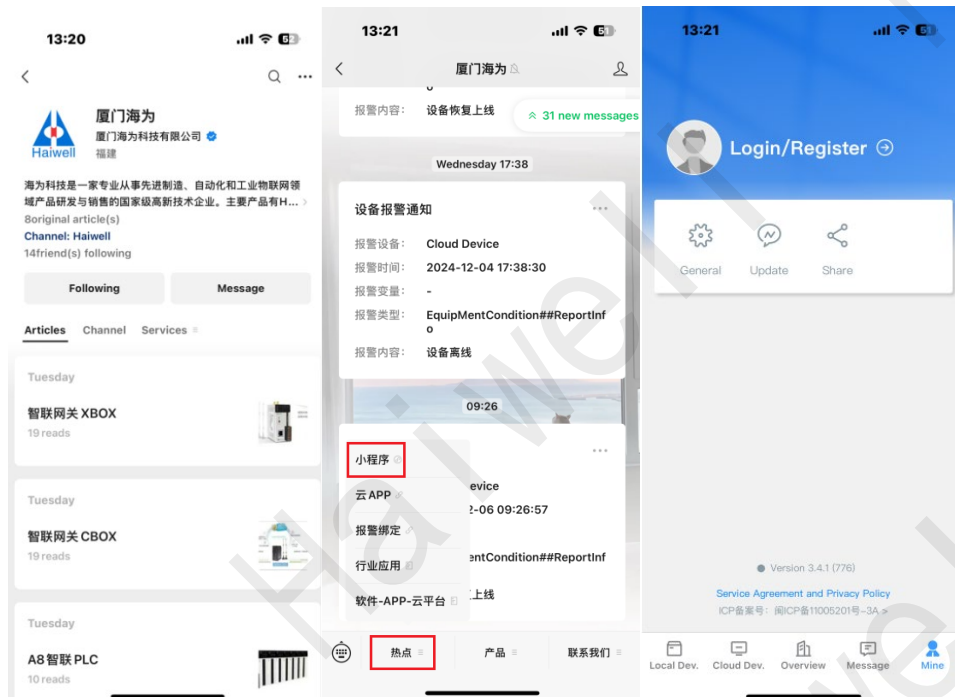

Figure68 Download the QR Code of Haiwell Cloud APP

**Note: The WeChat mini program does not have a local device and requires downloading the Haiwell APP.**

### (2) Haiwell Cloud APP/WeChat Mini Program Scan Code to Bind QR Code

Enter the HMI background settings interface, click on 'Cloud Settings', turn on the cloud switch, and a QR code and machine code will pop up. If the cloud status shows offline, please check if the HMI has successfully connected to the external network.



Figure69 Binding Cloud Settings QR Code

Log in to the Haiwell Cloud APP on your mobile phone, enter the local device interface, click the button  in the upper left corner of the main interface, and then click on the dropdown menu to scan. Scan the QR code to add the device. A confirmation binding prompt box pops up on the device, click **【Confirm】**,





Figure72 HMI Cloud Setting Binding Information

### (3) Remote Monitoring and Control

Open the Haiwell Cloud app on your phone and enter the cloud device; Find the corresponding device and click on **【Access】** in the bottom right corner to remotely access the device. If the current project allows remote operation, users can control the device remotely through their mobile phone.

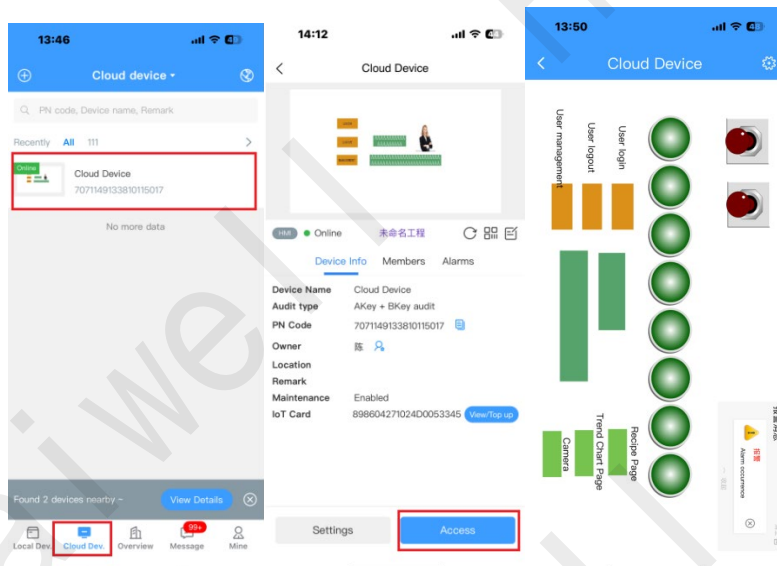

Figure73 Remote Access via Mobile APP

## 2.6 Network Settings

Intelligent HMI supports a variety of network connection modes Ethernet, WIFI, 4G, through different networking modes, so that the Intelligent HMI connected to the Internet, remote access, remote operation, remote transparent transmission operation.

### (1) Ethernet Connection

Go to the HMI background Settings screen, Tap **【Network Settings】** to enter the Ethernet Settings screen, Open the **【Network Switch】**, the network type includes DHCP and Static IP.

**Dynamic IP:** Connect the network cable, select **【DHCP】**, and click **【Save】**, The device automatically obtains an IP address.

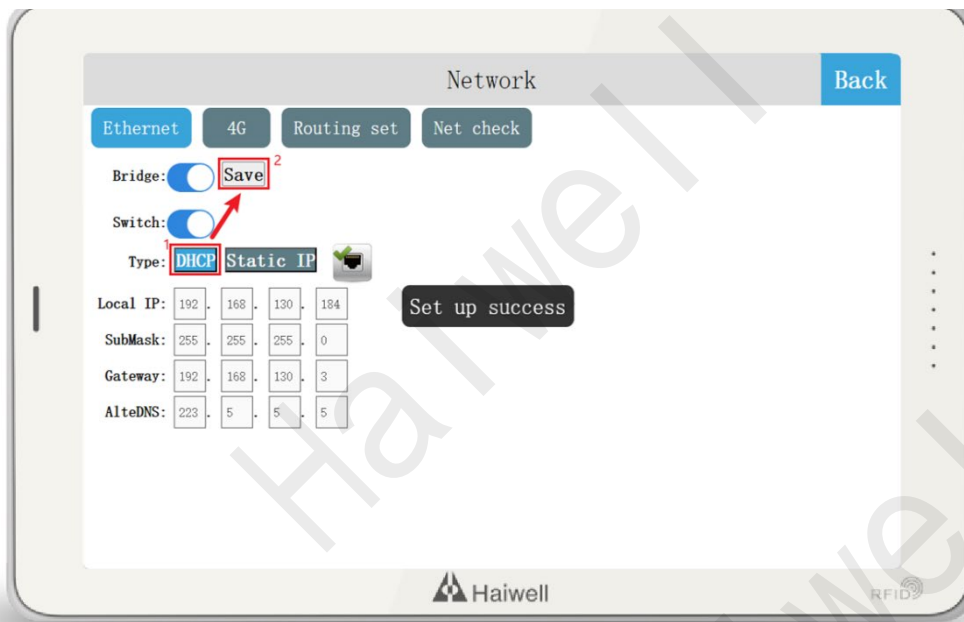

Figure74 Obtaining IP Dynamically

**Static IP:** Connect the network cable, Select **【Static IP】** for the network type, Enter the correct IP address, subnet mask, default gateway, and DNS. Click **【Save】**.

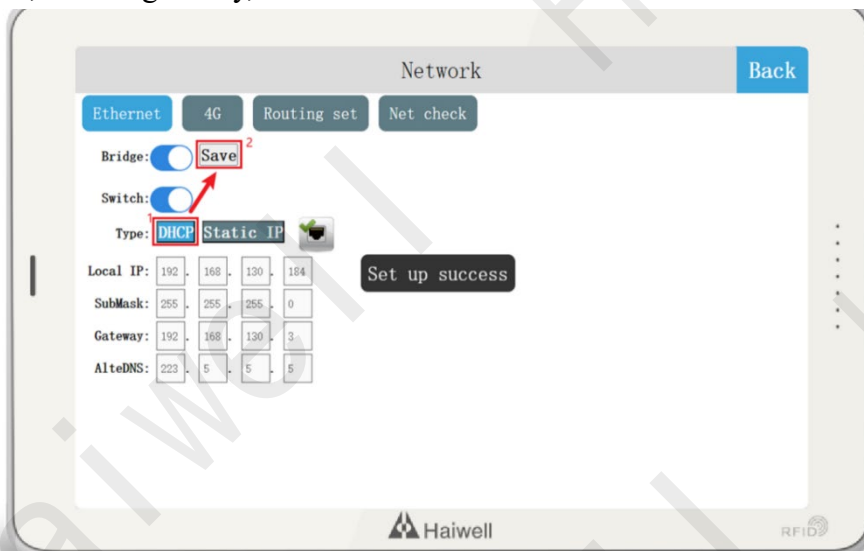

Figure75 Static IP Settings

**Note:** After the touch screen network port is plugged into the network cable of the external network, enter the background Settings - **【Network Settings】**, and obtain the IP address dynamically first, select **【DHCP】** and then click **【Save】**, it will automatically obtain the IP address and make the touch screen for the external network. Then select **【Static IP】** to change the IP address, and click **【Save】**.

## (2) WIFI Settings

Click **【WIFI Settings】** to enter the WIFI setting interface, which supports connecting to the network through WIFI. Enter the WIFI setting interface, turn on the WIFI switch, select the target WIFI account, enter the correct WIFI password, and connect to the WIFI network after verification.

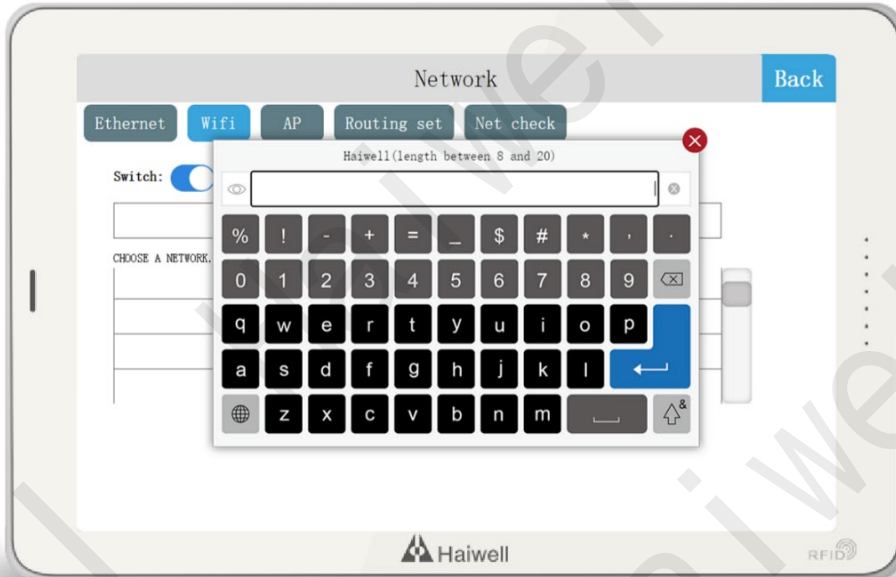

Figure76 WIFI Password Settings

After the connection is successful, a green check mark is displayed "✓".

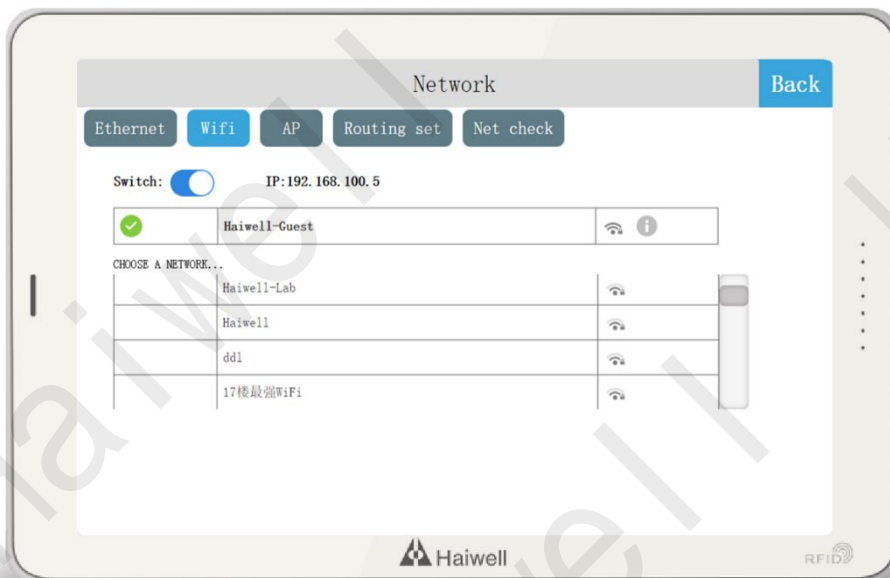

Figure77 WIFI Connection Successful

After the connection is successful, gray "i" is displayed. Click the gray "i" icon to set the IP address, subnet mask, default gateway, and DNS static or dynamic. After setting, click **【Save】** to set the IP address of WIFI. Click "Ignore this network", that is, disconnect the WIFI connection, if you want to use the WIFI, you need to re-enter the password to connect.

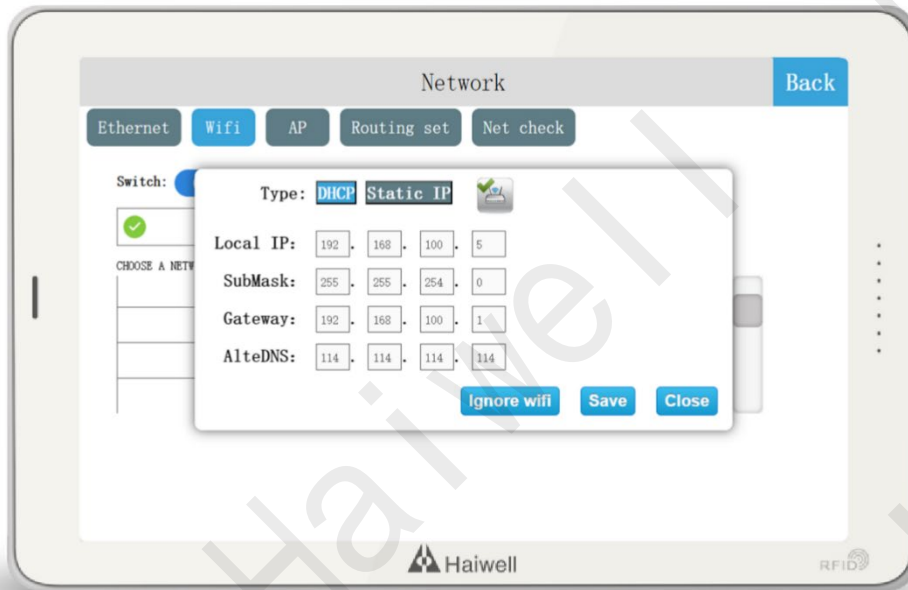

Figure78 WIFI IP Settings

Note: ①The HMI needs to be connected to the WIFI antenna, otherwise the signal strength is weak and the WIFI cannot be connected or searched.②WIFI can only search the AP band 2.4GHz, 5GHz cannot be searched, if you use a mobile phone to open WIFI hotspot, please pay attention to set the hotspot band.

### (3) Personal Hotspot

Click **【AP】** to enter the personal hotspot interface, the HMI built-in network card can also share the WIFI hotspot for other users. Turn on the personal hotspot switch, set the hotspot name and password, and you can share the WIFI hotspot for other users.



Figure79 Personal Hotspot Settings

Set the hotspot name, click "Hotspot name", the hotspot name input box is displayed. Enter the hotspot name, click **【Enter】** , and then click **【Save】** to save the added hotspot name.

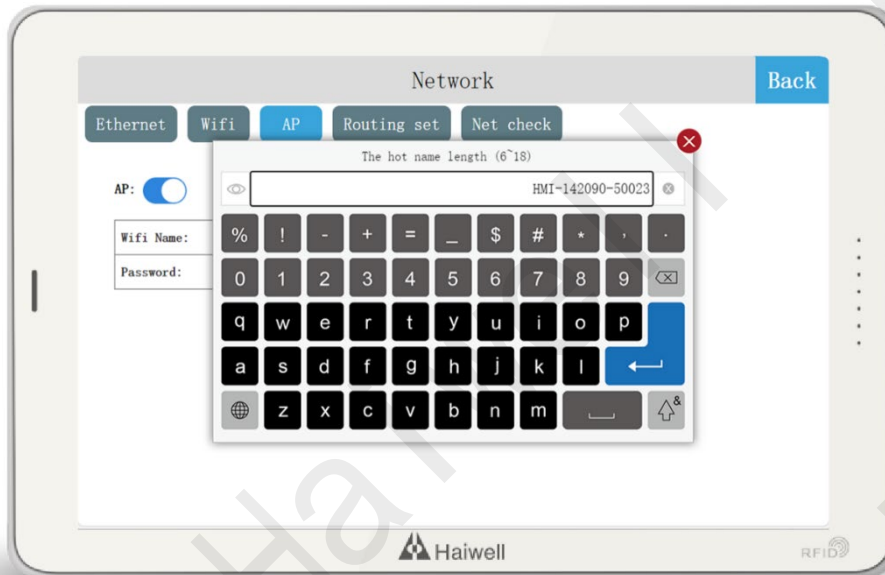



Figure80 Personal Hotspot Settings Name

Set the password, click "Password", the password input box appears, click the upper left corner of the input box  to switch the plain text and cipher text of the password. Enter the password, click **【Enter】**, and click **【Save】** to save the added password. The factory default WIFI password of the HMI is empty.

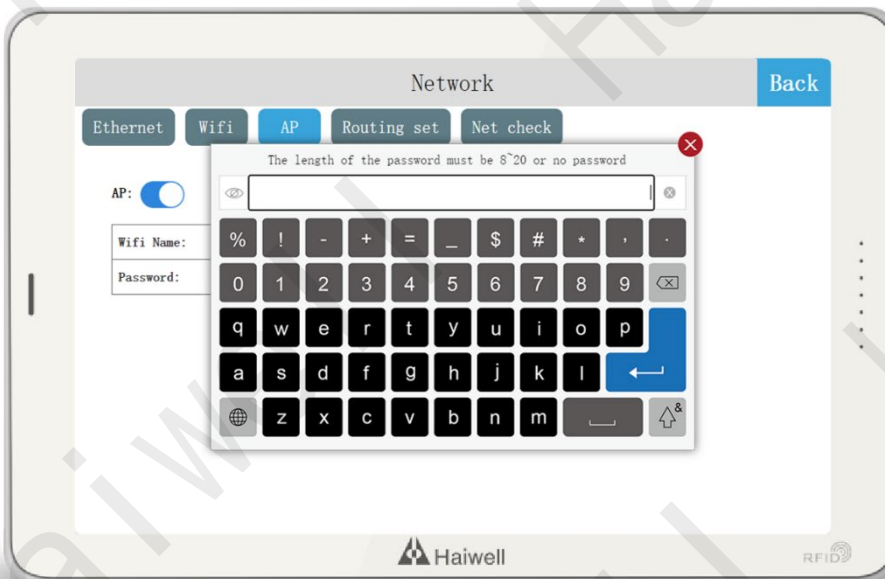

Figure81 Personal Hotspot Setting Password

**Note:** The hotspot name contains 6 to 18 characters, and the password can be left blank or 8 to 20 characters. Click Enter to enter the hotspot name, the password will not be displayed in the corresponding position, and a pop-up prompt will be displayed.

#### (4) 4G Configuration

Click **【4G】** to enter the 4G configuration interface, which contains two modes: internal eSIM card and external SIM card. Users can identify or obtain the relevant information of the device and its SIM card

through three codes: IMEI (International Mobile Equipment Identity Code), IMSI (International Mobile User Identification Code) and ICCID (Integrated Circuit Card Identification Code).

**Disable 4G:** turn off the 4G switch and the message "Closing..." is displayed. If only the IMEI code is displayed, the device is not connected to the 4G network.



Figure82 4G is not Enabled

**Enable 4G:** Turn on the 4G switch and pop up the "4G Option" pop-up window. Users can click "Enable built-in eSIM" or "Enable External SIM Card" as required. After clicking, the pop-up message "Closing..." when displayed "Setting succeeded", the device can access the 4G network.

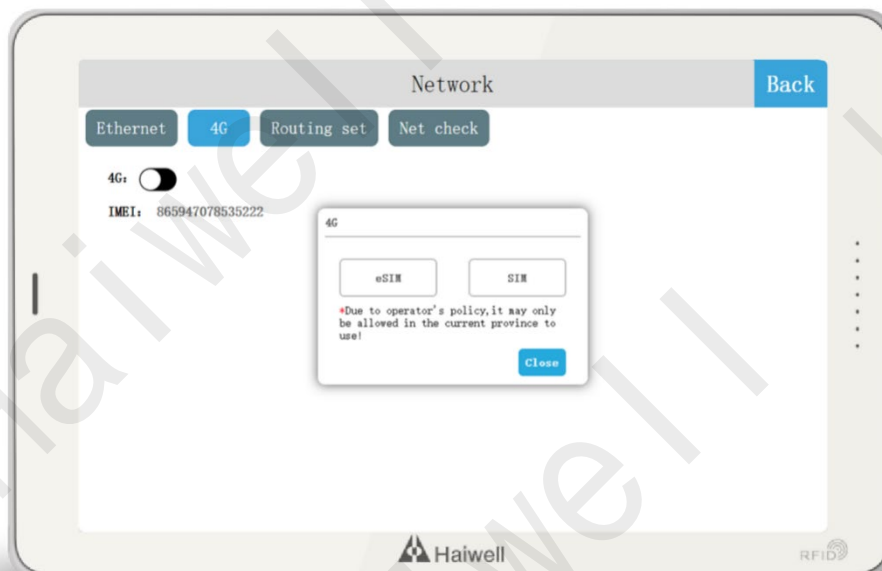

Figure83 Enabling 4G

**eSIM Card Mode:** When the eSIM card mode is enabled, Using is displayed on the right of the eSIM card information, and you can view the built-in eSIM card information.



Figure84 Enabling the eSIM Card

Click **【View data】** to display the total data and remaining data of the eSIM card in this period.

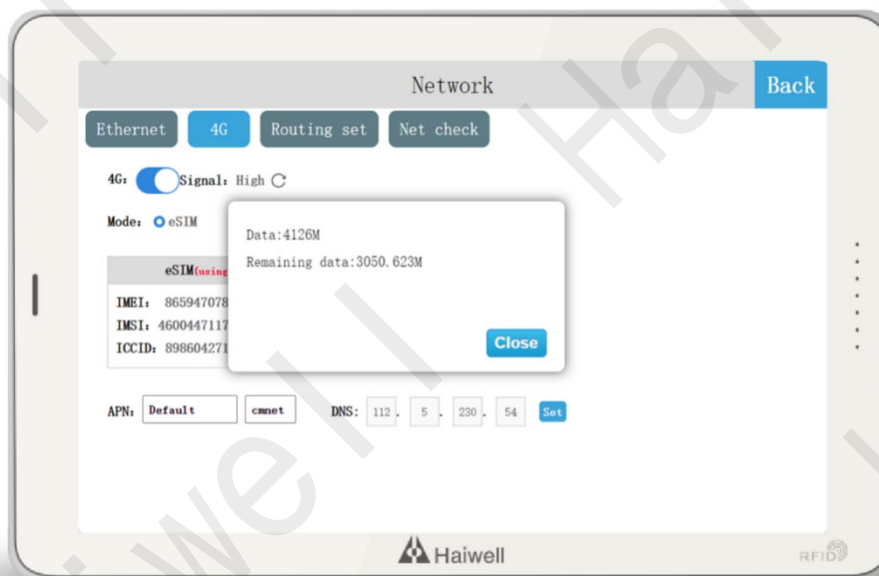

Figure85 Check Remaining Data Balance

**SIM Card Mode:** When the SIM card mode is enabled, "In Use" is displayed on the right of the SIM card information, and information about the external SIM card can be viewed.



Figure86 Enabling the SIM Card

Click **【View data】**, if the SIM card is not the Internet of Things card provided by Haiwell, the prompt "Failed to obtain data" will pop up.



Figure87 Viewing Data

**APN Settings:** Click "Default" on the APN, You can select "Default" or "Custom". If you select "Custom", you can modify the APN (Network access point) name, user name, password, and dial number as required.

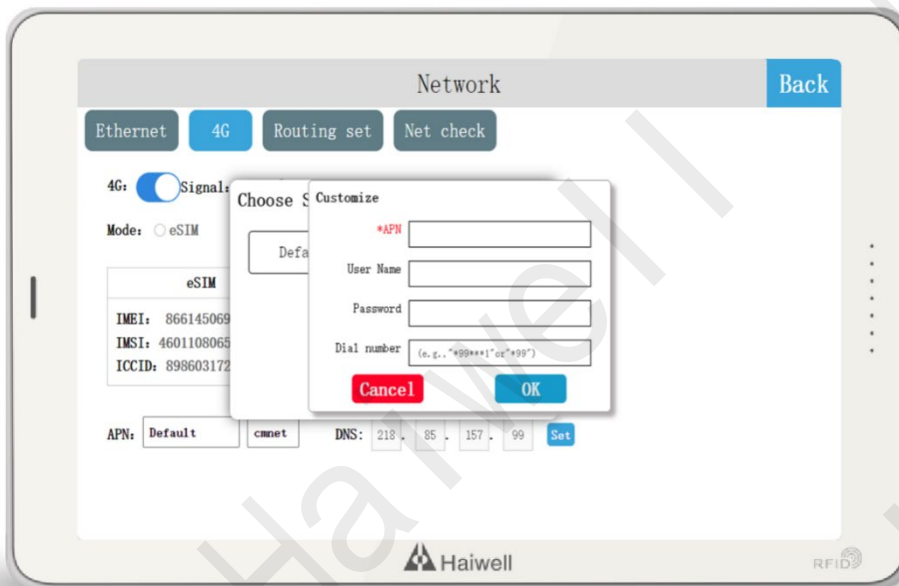

Figure88 APN Settings

**DNS Settings:** Background 4G DNS Settings function, to achieve self-configuration of DNS, to solve the 4G network automatically obtain probabilistic DNS anomalies, resulting in the 4G network cannot be used.

Click **【Settings】** on the DNS page, the DNS configuration pop-up window is displayed. You can select the DNS server assignment mode. You can customize the DNS server assignment mode by selecting Manual.

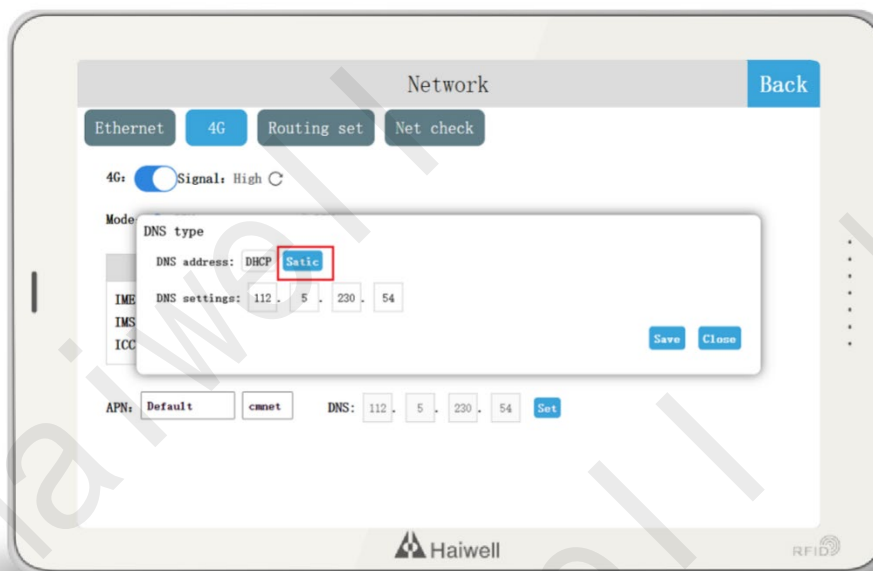

Figure89 DNS Settings 1

Click the DNS server address input box to modify the value of the address.

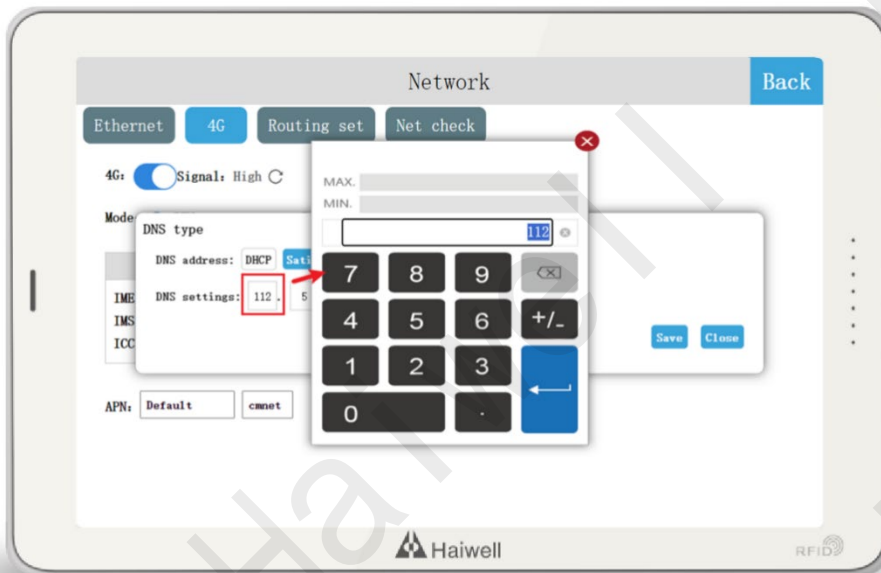

Figure90 DNS Settings 2

After setting the DNS server address, click **【Save】** to save the DNS server address.

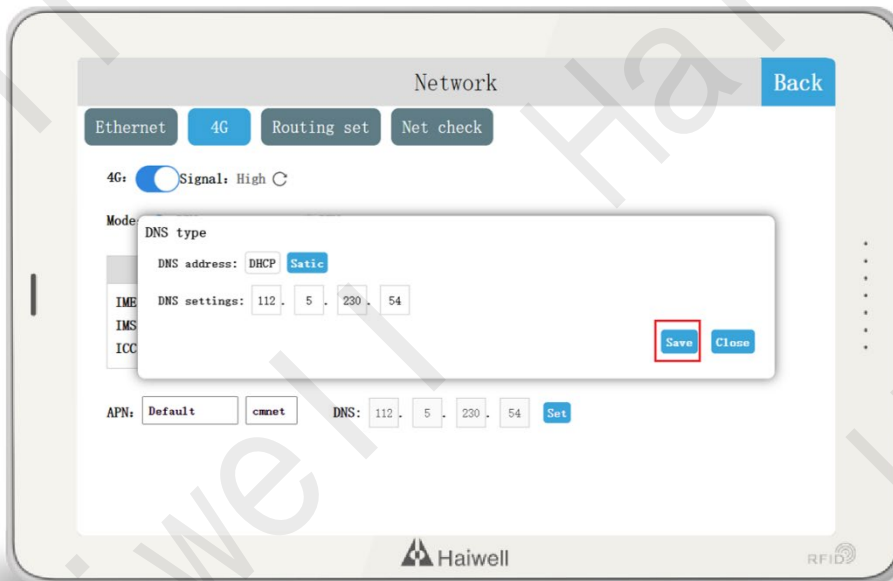

Figure91 DNS Settings 3

The DNS server is configured successfully.

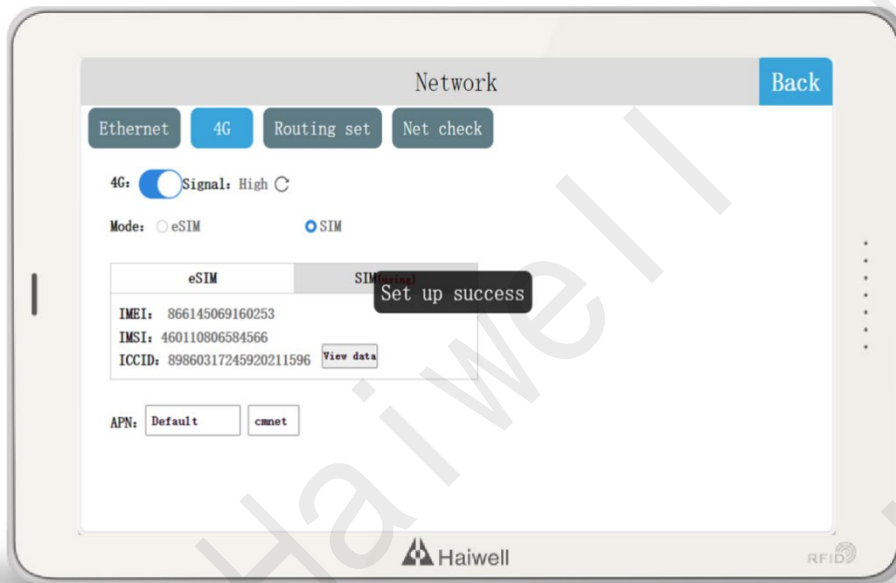

Figure92 DNS Settings 4

Note: DNS information is not displayed when the signal strength is "No Service".



Figure93 DNS not Displayed

### (5) Network Configuration Model

The new series HMI is available in the following four models with different network configurations.

#### Standard version (example: A7 Pro)

The HMI Standard Edition only has Ethernet, does not include WIFI/4G/ hotspot/routing module, and is only provided by the network cable.

#### WIFI version (example: A7 Pro-W)

The HMI with WIFI version only includes Ethernet and WIFI, does not include 4G/ hotspot/routing module, and is provided by network cable /WIFI.

**With 4G version (example: A7 Pro-G)**

HMI with WIFI version includes Ethernet and 4G and routing module, does not contain WIFI/ hot spot, provided by network cable /4G, routing mode is: not enabled routing mode /4G client mode, about the specific use of each routing mode will be explained later.

**4G with WIFI version (example: A7 Pro-GW)**

HMI with 4G and WIFI version includes Ethernet /WIFI/4G/ routing module, which provides the network by Ethernet /WIFI/4G. The routing modes are: not enabled routing mode/wireless access point mode /4G routing mode/client mode/relay mode /4G client mode. The specific use of each routing mode will be explained later.

**(6) Route Configuration**

Route configuration not only supports the device to access the Internet through "LAN", "WIFI", and "4G" modes, achieving "device Internet access". In addition, you can share a LAN or directly create a hotspot to "provide external network connections".

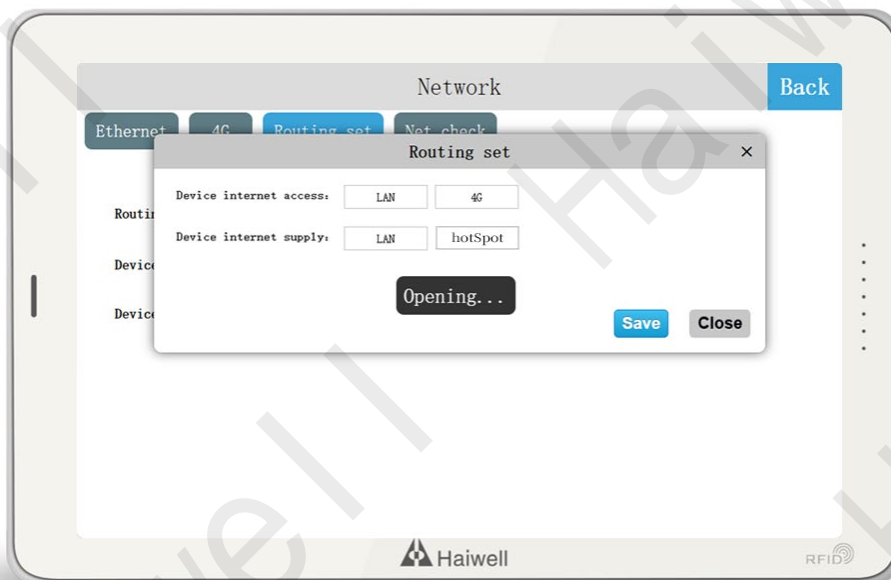

Figure94 Route Settings

**The Routing Mode is Disabled:** On the HMI background Settings screen, tap **【Network Settings】** to enter the route configuration screen. Disable the route switch then the prompt "Closing..." will pop up, next hides the Internet access and external network information of the device. In this case, the routing mode is disabled.

In "Route Disabled" mode, only the routing function of the current Ethernet, WIFI, and 4G is disabled. In this mode, the hotspot supports only the local area network (LAN) and does not support the Internet. The function Settings of Ethernet, WIIF, and 4G remain unchanged.



Figure95 Disable Routing Mode

**Wireless Access Point Mode:** Enter the HMI background setting screen, click **【Network Settings】** to enter the route configuration screen, turn ON the route switch, and the setting screen will pop up (it will pop up when the switch is set to ON from OFF, otherwise you need to click "Setting" to enter the setting screen), set the device Internet access mode to "LAN", set the external network supply mode to "Hotspot", and click "Save". The message "Setting succeeded. 4G and WIFI have been turned off for you." is displayed. "Is set to wireless access point mode.

In "Wireless Access Point" mode, only the wired network provides the network. Other devices can connect to the personal hotspot of the device to access the LAN and the external network.

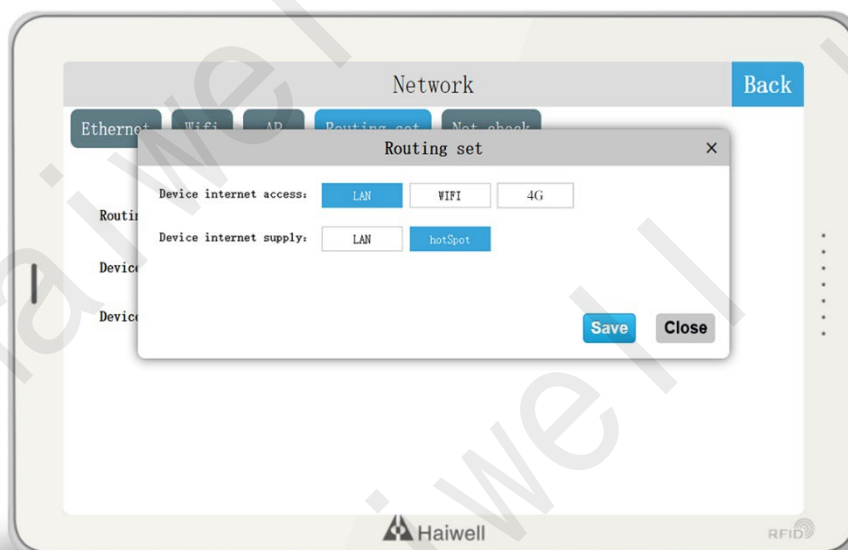

Figure96 Wireless Access Point Mode

**4G Routing Mode:** Enter the HMI background setting screen, tap **【Network Settings】** to enter the

routing configuration screen, turn on the routing switch, tap "Settings", set the device Internet access mode to "4G", set the external network mode to "hotspot", click "Save", and the pop-up message "Setting succeeded, WIFI has been turned off for you." In this case, the routing mode is set to 4G.

In "4G routing" mode, only 4G provides the network for the device. Other devices can connect to the personal hotspot of the device to access the LAN and the Internet. The wired network in this mode supports only LAN networks.

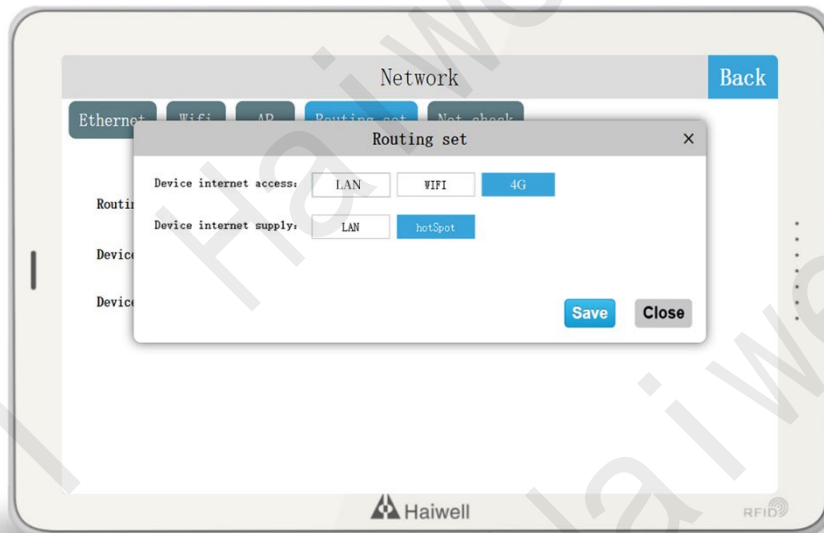

Figure97 4G Routing Mode

**Relay Mode:** Go to the HMI background Settings screen, tap **【Network Settings】** to enter the route configuration screen, turn on the route switch, tap "Settings", set the device Internet access mode to "WIFI", set the external network mode to "Hotspot", and tap "Save", The message "Setting succeeded, 4G has been disabled for you" is displayed. In this case, the relay mode is set.

In "relay" mode, only the WIFI connected hotspot provides the network. First, connect to a hotspot that can access the Internet, and then provide a network for other devices through the personal hotspot of the device, supporting the local area network and the external network. The wired network in this mode supports only LAN networks.

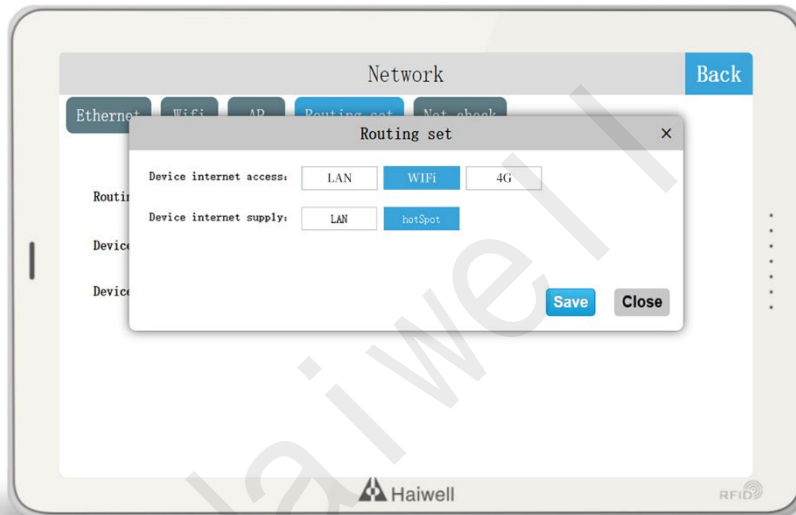

Figure98 Relay Mode

**Client Mode:** Go to the HMI background setting screen, tap **【Network Settings】** to enter the route configuration screen, turn on the route switch, tap "Settings", set the device Internet access mode to "WIFI", set the external network mode to "LAN", click "Save", and the prompt "Setting succeeded, 4G has been disabled for you" is displayed. , then set to the client mode;

In the "client" mode, the network is provided by the WIFI connected hotspot, and the HMI is equivalent to the router. The HMI connects to the wired network, and then connects to the device through the cable to provide the network for the device. The personal hotspot function is not supported in this mode.

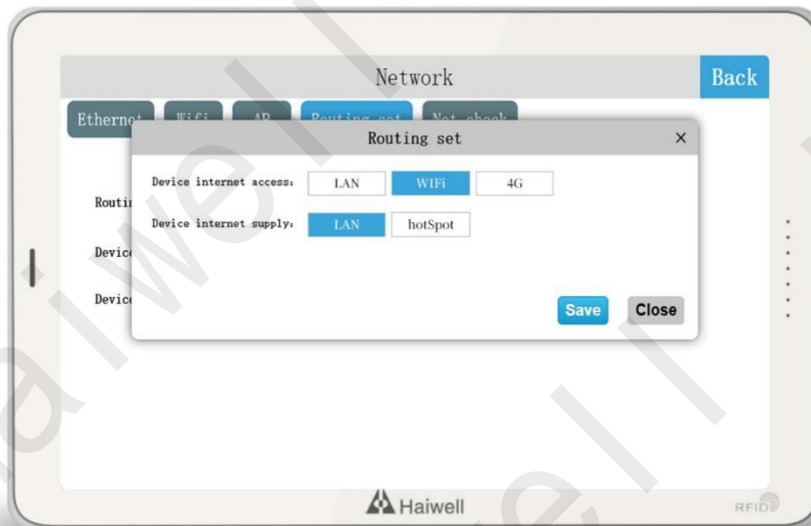

Figure99 Client Mode

**4G Client Mode:** Enter the HMI background setting screen, tap **【Network Settings】** to enter the route configuration screen, turn on the route switch, tap "Settings", set the device Internet access mode to "4G", set the external network mode to "LAN", click "Save", and the prompt "Setting succeeded, WIFI has been turned off for you" will be displayed. In this case, set to the 4G client mode.

In "4G client" mode, the network is provided by 4G, and the HMI is equivalent to a router. The HMI connects to the wired network, and then connects to the device through the wired network to provide the network for the device. The personal hotspot function is not supported in this mode.

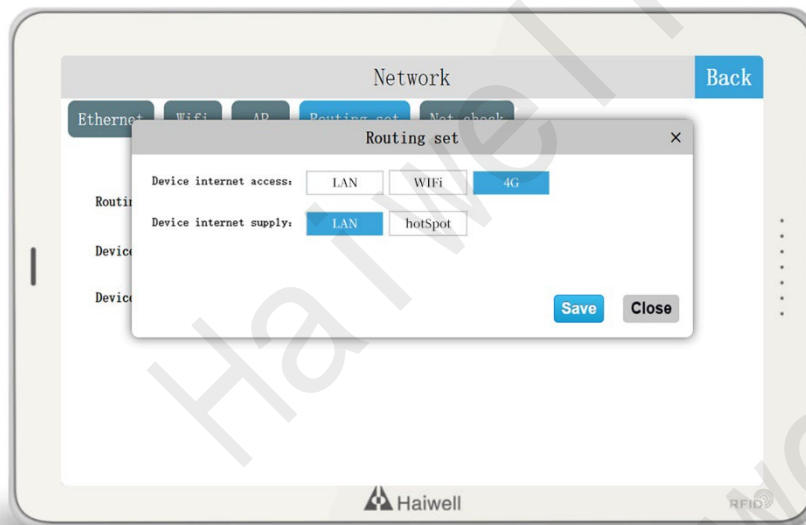



Figure100 4G Client Mode

### (7) Network Diagnosis

**External Network Access:** Use network diagnosis, click the website , select the website to access, if the return information indicates that the device is connected to the network.

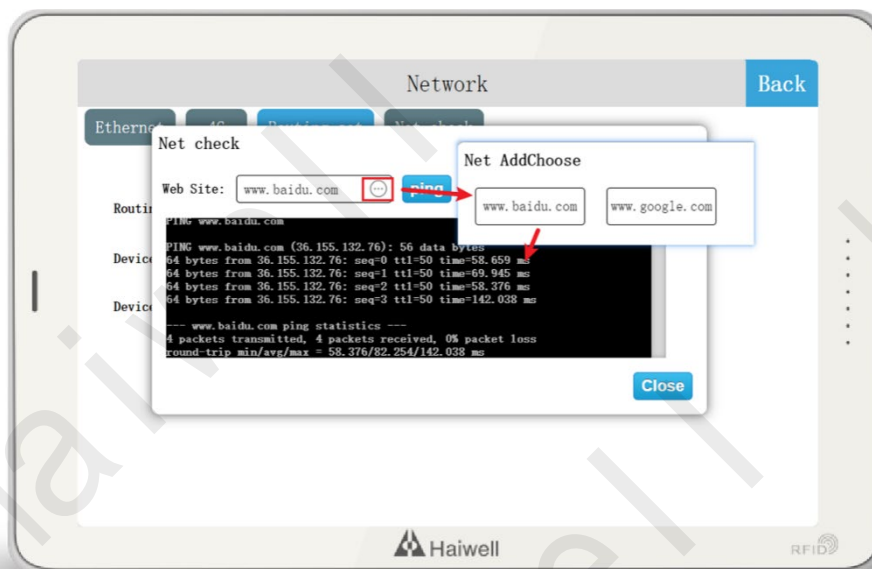

Figure101 Internet Access

**LAN Access:** Use network diagnosis, click on the website, enter the corresponding IP address of the device you want to access, such as the IP address of the HMI communication PLC is 192.168.13.212, if the following information is returned, the successful access to the mutual communication.

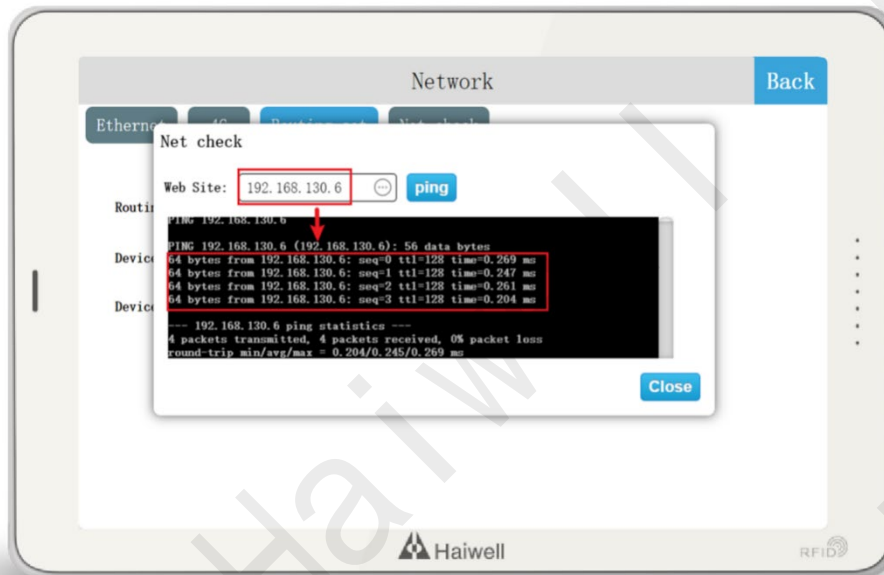

Figure102 LAN Access

## VI. Configuration SCADA Project

### 1. Project Establishment

This paper takes a new project as an example to realize HMI and Siemens 200smart Ethernet communication, and can achieve local access and remote access to HMI screen control PLC.

#### 1.1 Add New Project

**Step 1:** Open the Haiwell Cloud Configuration SCADA software and click "New Project" on the configuration software start page.

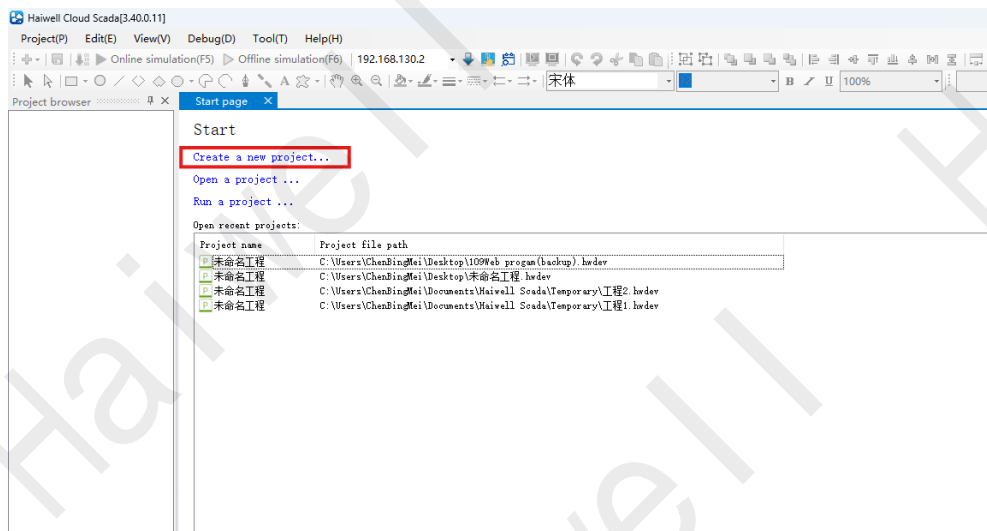

Figure103 New Project

**Step 2:** Click "Create a new project" and the project property window will pop up, the project name can be customized, and the corresponding operation platform can be selected. A7 Pro-G is taken as an example here, and Haiwell HMI A7 Pro (the model ending number -W or -G or -GW is a common operation platform) can be selected, and the screen resolution of the device used can be seen after selection. You can select an Angle as required. If the Angle is not set, the default value is 0°. Select LAN access to use the

LAN access function, you can use the Haiwell Cloud APP/ computer browser /TVBOX to access the LAN, the password can be set to empty, that is, you do not need to enter the password to access, and finally click "OK".

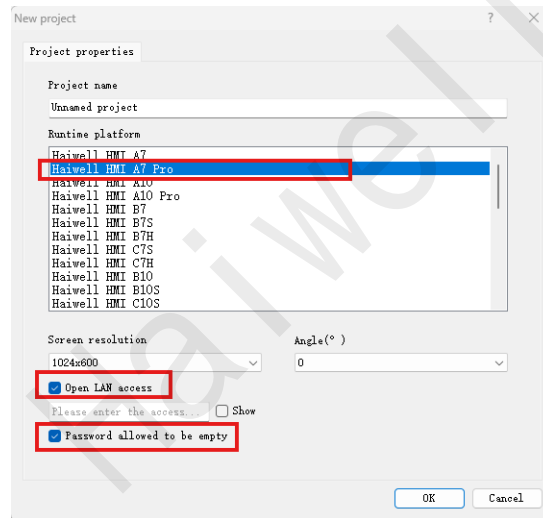

Figure104 Selecting a Running Platform

## 1.2 Add New Device

**Step 1:** Right-click Ethernet in Project Browser and choose "Add Device". Click OK.

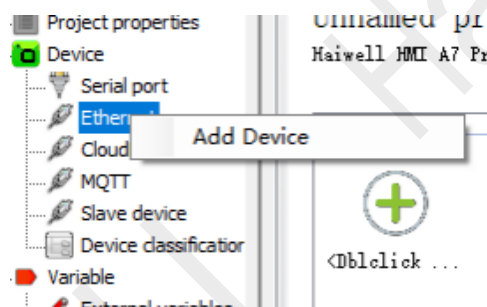

Figure105 Adding a Device

**Step 2:** Select Ethernet (TCP/IP) for the device interface, select the device on the left to find the corresponding Siemens model, and enter the IP address of Siemens PLC in the device properties.

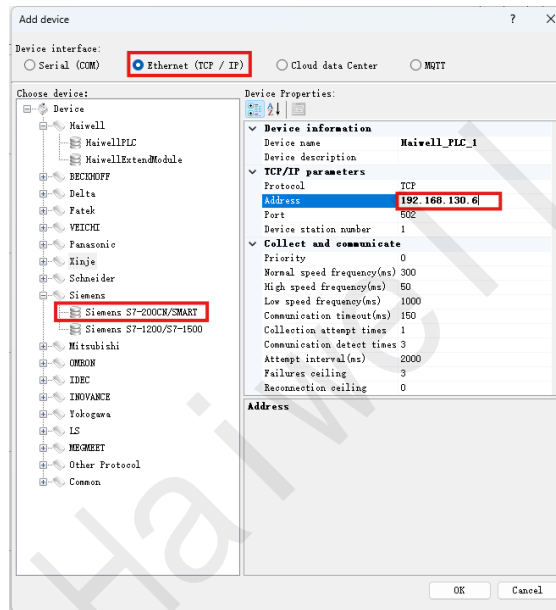

Figure106 Setting Device Communication Parameters

### 1.3 Add the New Variables

After you click OK, a prompt box will pop up asking you whether to define variables for the device immediately. Select Yes to add a Q0.0 and VW0.0 respectively.

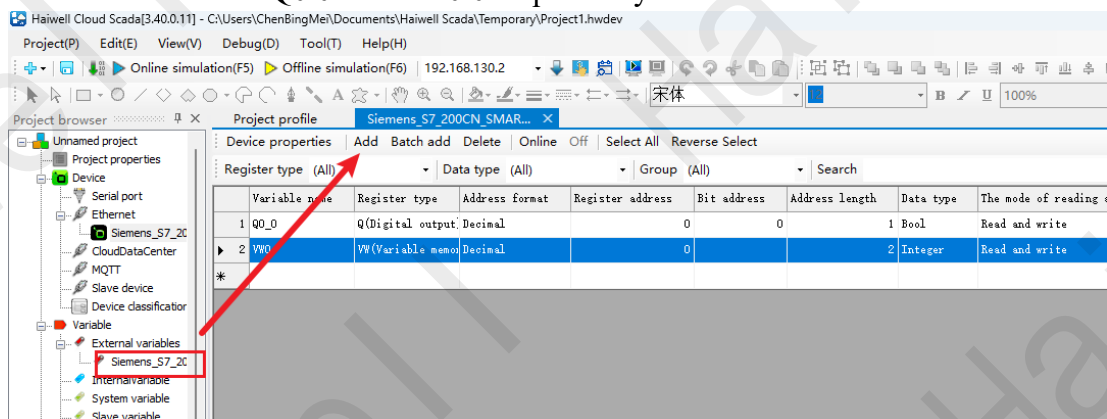

Figure107 Create New Variable

### 1.4 Edit Screen

Project browser select the main screen, in the right of the library - function components, drag "bit Settings" and "numerical display input" to the screen, double-click the meta binding variable.

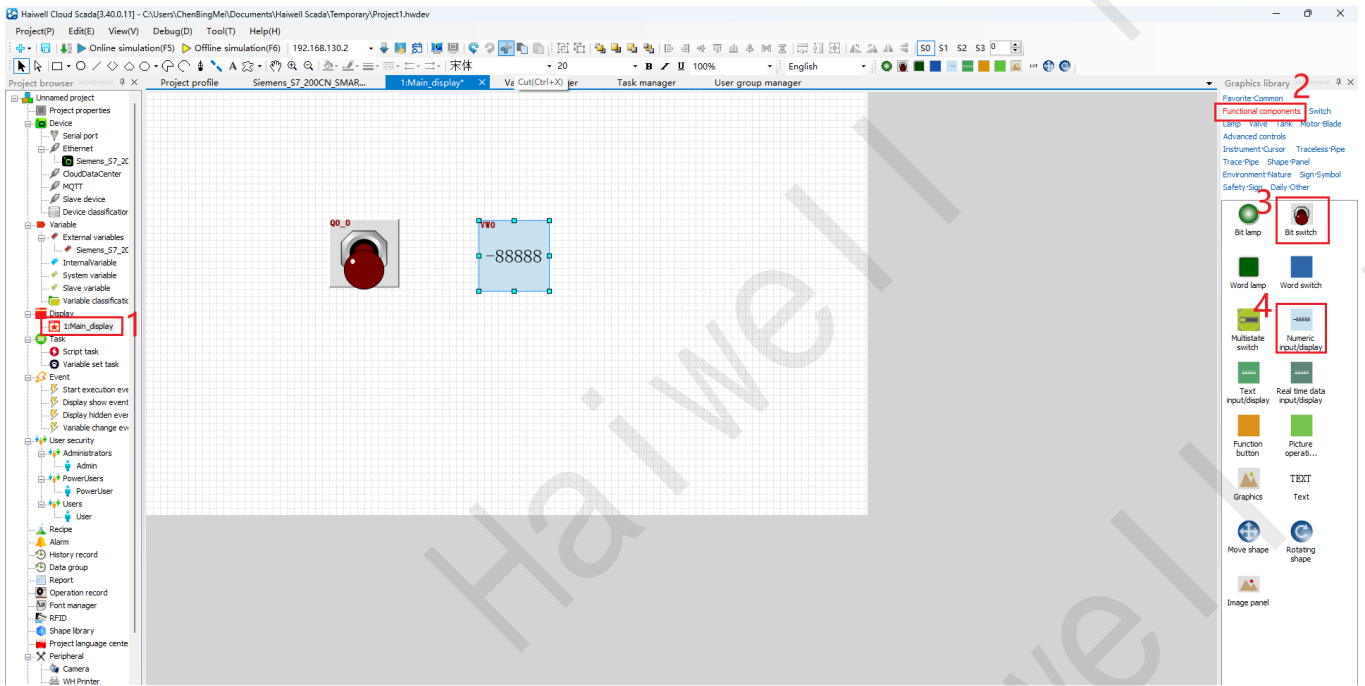
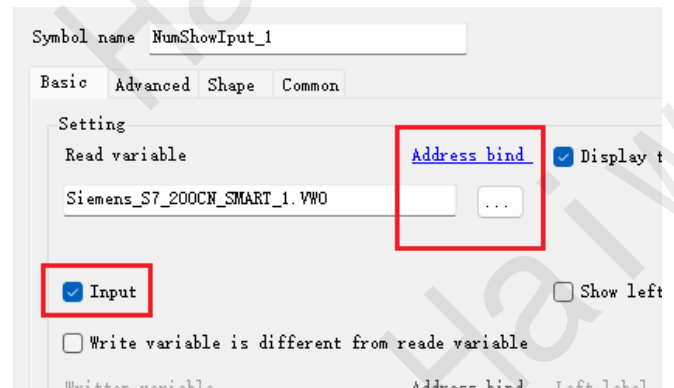

Figure108 Edit Screen

If users need to write the VW value to the PLC, you need to select Input in the value display input attribute, otherwise only read-only attribute.



(a)



(b)

Figure109 Meta Binding Variable

### 1.5 Debugging and Running

The developed and edited project can be run and debugged through "online simulation" and "offline simulation".

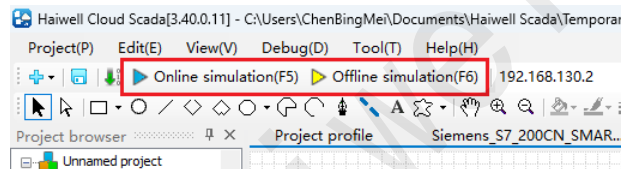

Figure110 Simulation and Debugging

#### (1) Online Simulation and Offline Simulation Differences

**Online Simulation:** take the port on the computer as the port of the HMI touch screen, communicate with the PLC, etc., for simulation and debugging.

**Offline Simulation:** that is, it does not communicate with the actual PLC, but only simulates the screen of the simulation operation.

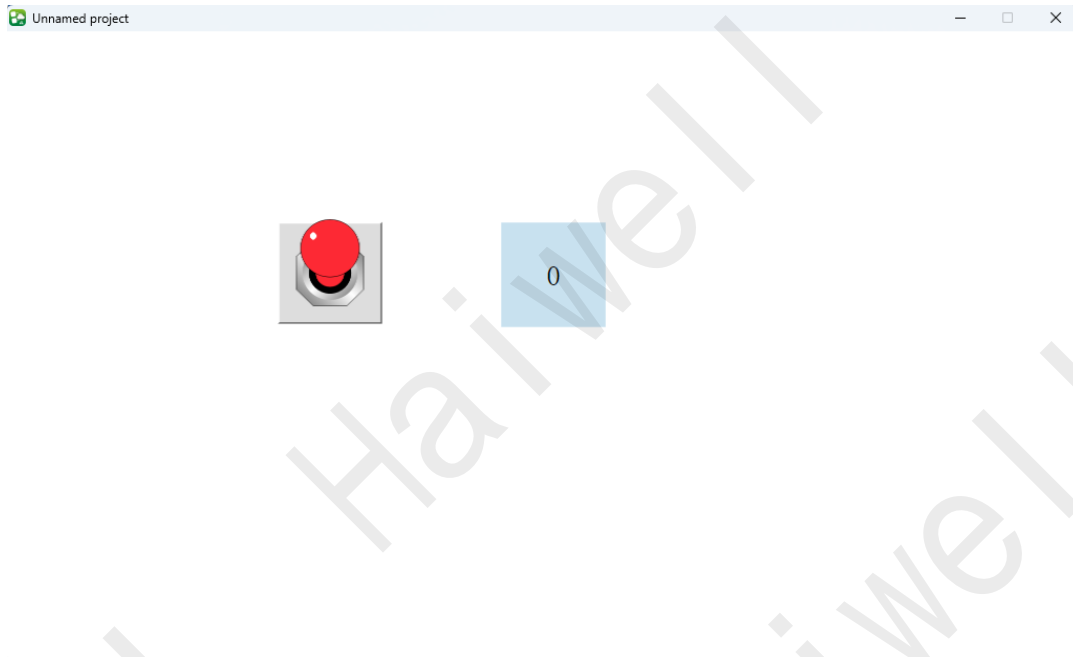



Figure111 Online/Offline Simulation Screen

## 2. Device Management Tool

Open the configuration design terminal  on the computer, click the device management tool icon in the menu bar to enter the device management tool; Or click **【Programs】**, expand the installation file **【Haiwell Scada】**, and click **【Haiwell Cloud HMI Manager】** to enter the device management tool.



Supports effective HMI control using local and cloud management.

### 2.1 Local Management

In local management, you can select and manage devices based on the IP addresses of devices on the LAN.

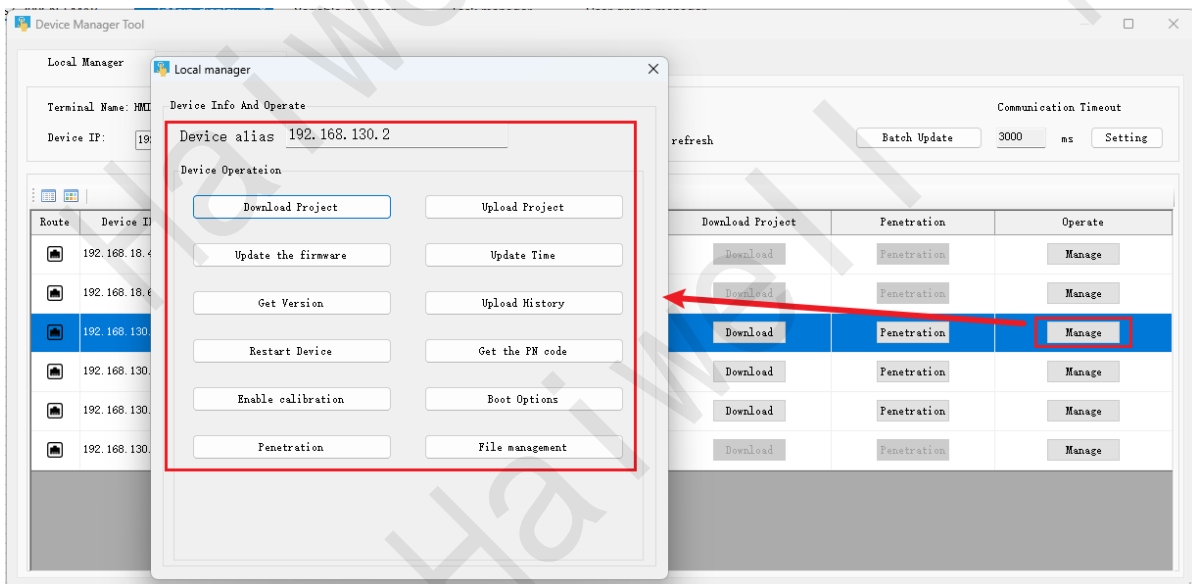

Figure112 Local Manager

## 2.2 Cloud Management

In cloud management, users can log in by mobile phone or email. Device administrators and owners can manage current devices, but common users do not have device management rights. Users can log in to the device Manager by entering the correct account and password. After login, users can select a specific device and perform management operations.

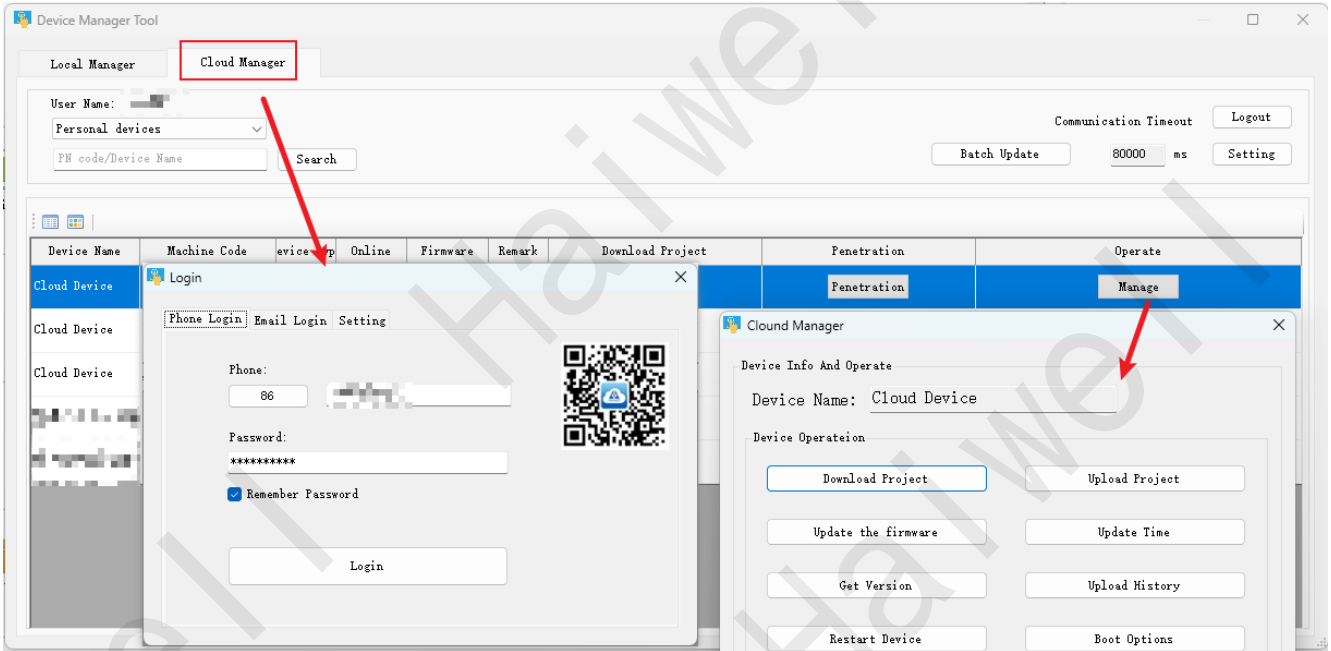

Figure113 Cloud Manager

## 3. Project Download

### 3.1 Local Download

**Step 1:** Go to the Device management tool. You can choose to use local management or cloud management, find the corresponding HMI, and click "Download Project".

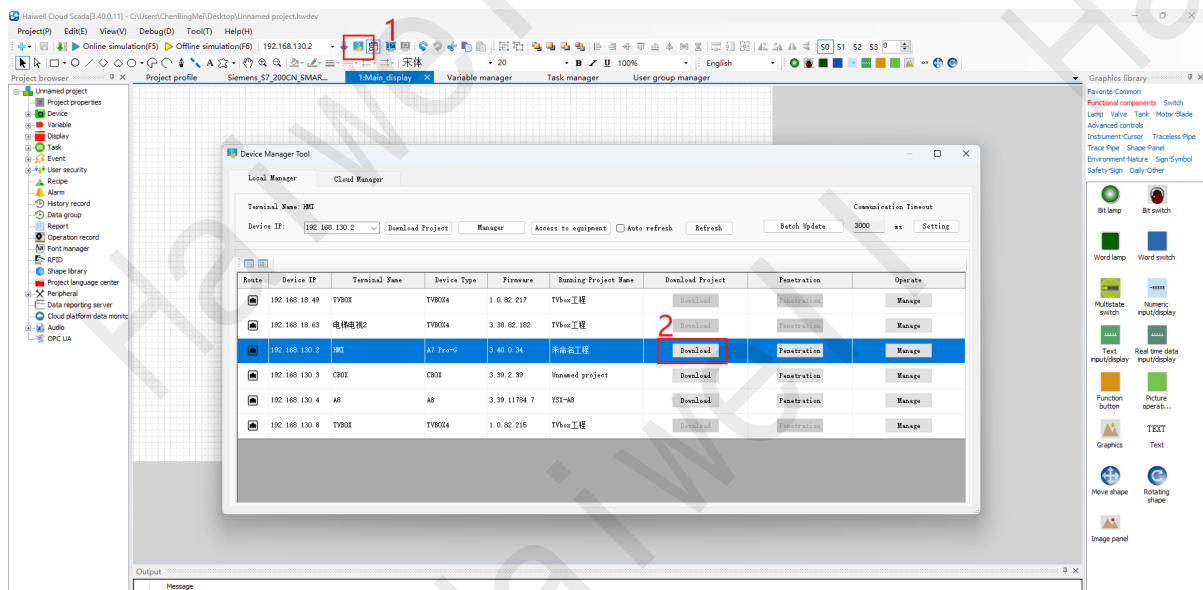

Figure114 Local Download Project

**Step 2:** In the confirmation download interface, you can choose whether to retain history and alarm

records, whether to retain recipes, and whether to pack fonts for download according to your needs. You can check it by default and click "OK".

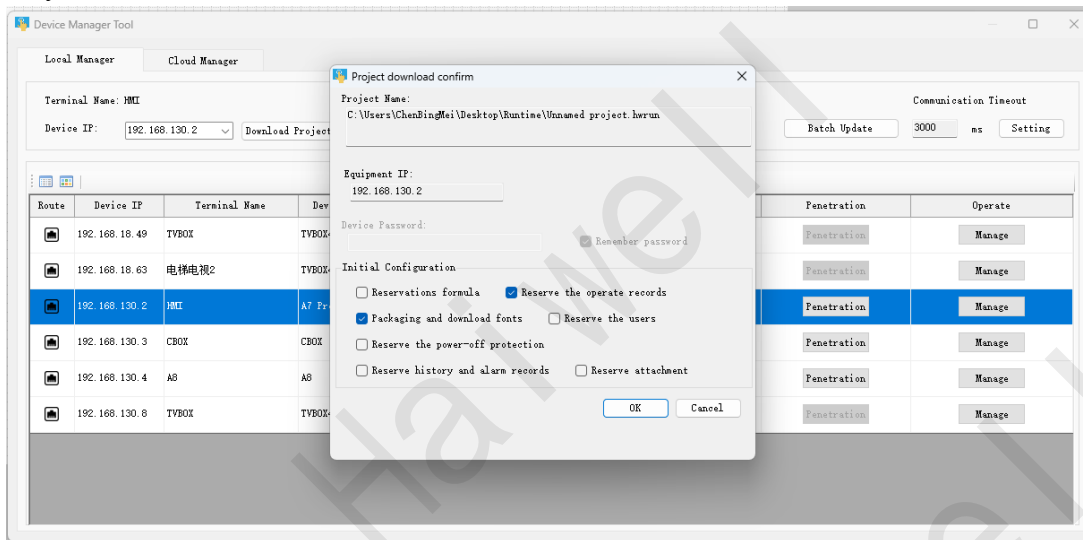

Figure115 Project Download Confirmation

**Step 3:** Wait until the message "Download success!" is displayed. Click "OK" to run the new project on the HMI.

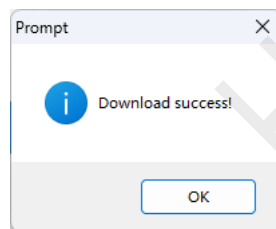

Figure116 Download Successfully

### 3.2 Remote Download

**Step 1:** To use cloud management, you need the HMI to connect to the Internet and the cloud is online. Log in to the cloud APP account and password, find the bound HMI, and select Download Project.

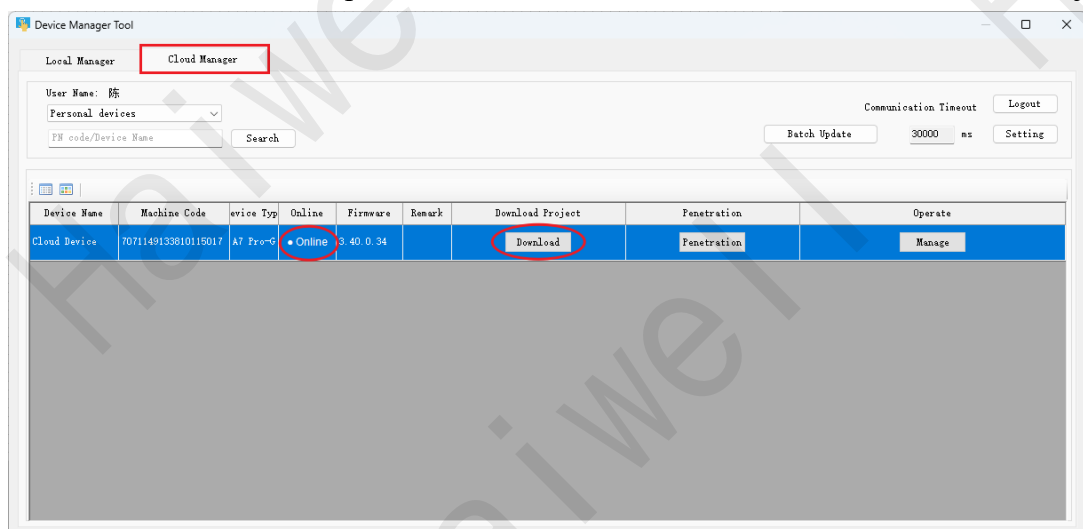

Figure117 Remote Download Project

**Step 2:** The follow-up is the same as the local download, and will not be summarized here.

## 4. Project Operation

After the project download is successful, wait for HMI restart, after the successful restart, the touch screen will automatically open the project start screen, the toggle bit is set to on, the value displays the input write value of 10, and you can observe the PLC monitoring to see that there is a successful write.

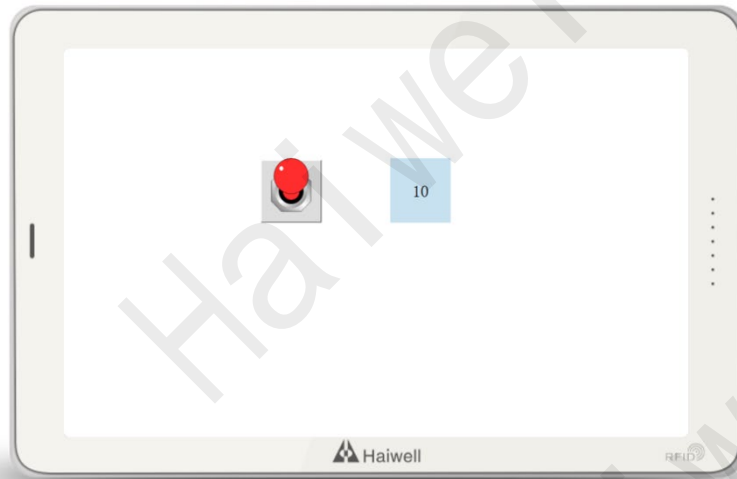

Figure118 HMI Running Screen

Address	Format	Value	New Value
1 CPU_Output0	Bit	2#1	
2 VW10	Signed	+10	
3	Signed		
4	Signed		
5	Signed		

Figure119 PLC Real-time Monitoring

## 5. Local/Remote Access HMI Screen

### 5.1 PC Local/Remote Access

#### (1) PC Local Access

**Method 1:** Local management After downloading the project, check the project properties to run LAN access, you can enter the HMI IP address in the browser and press Enter to locally access the HMI screen (for example: 192.168.13.202).



Figure120 Enter IP in the Browser

**Method 2:** Local management in the Device management tool Click Access Device. The browser is automatically displayed to access the device on the LAN.

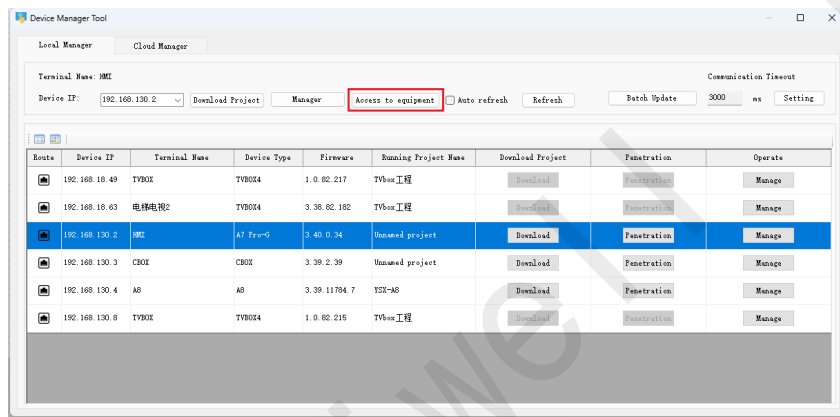

Figure121 Manage Access Devices Locally

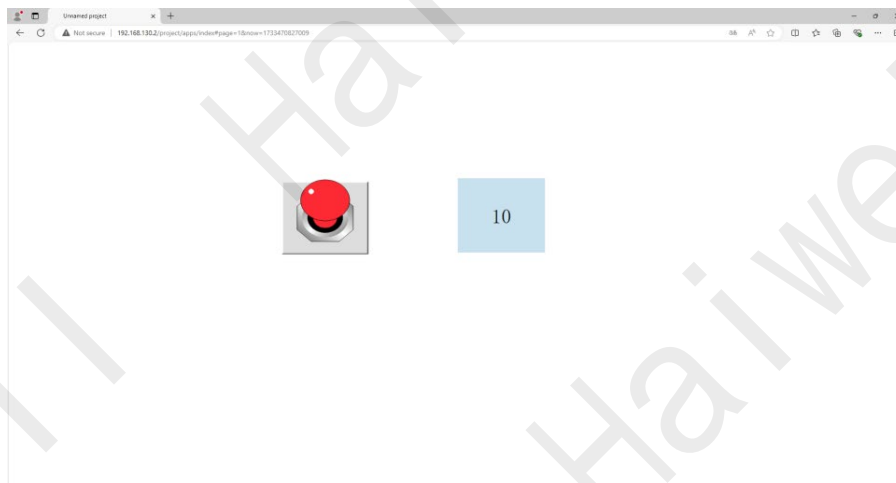

Figure122 Browser LAN Access

## (2) PC Remote Access

**Step 1:** open the computer browser, type <https://ecloud.haiwell.com/> access to the Haiwell for IIoT at cloud platform, login password is selected to individual users into the platform.

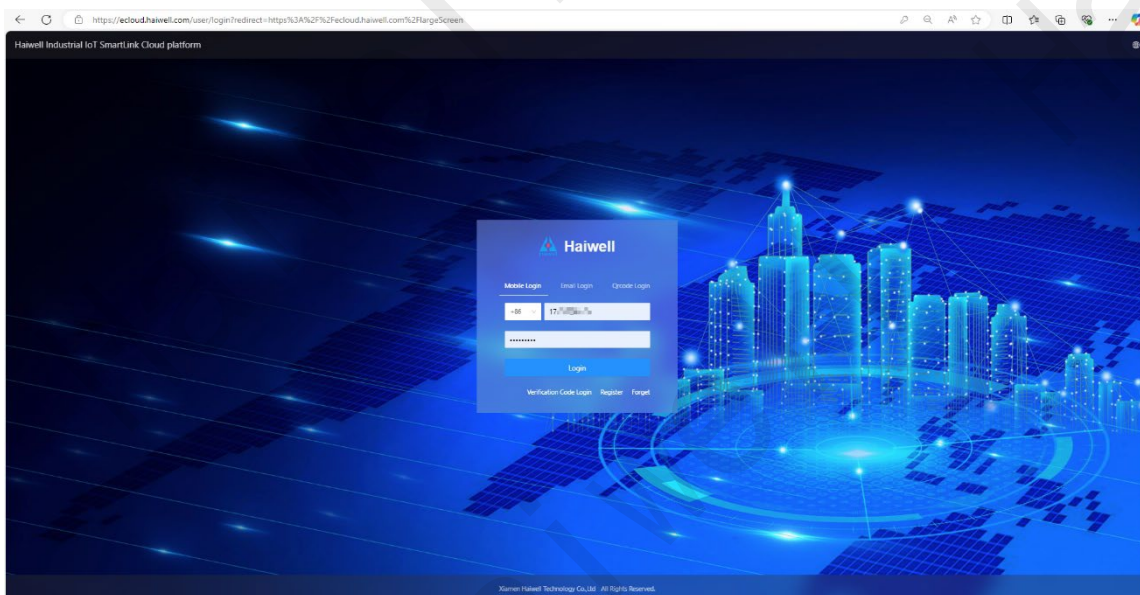

Figure123 Log in Haiwell IIOT Intelligent Cloud Platform

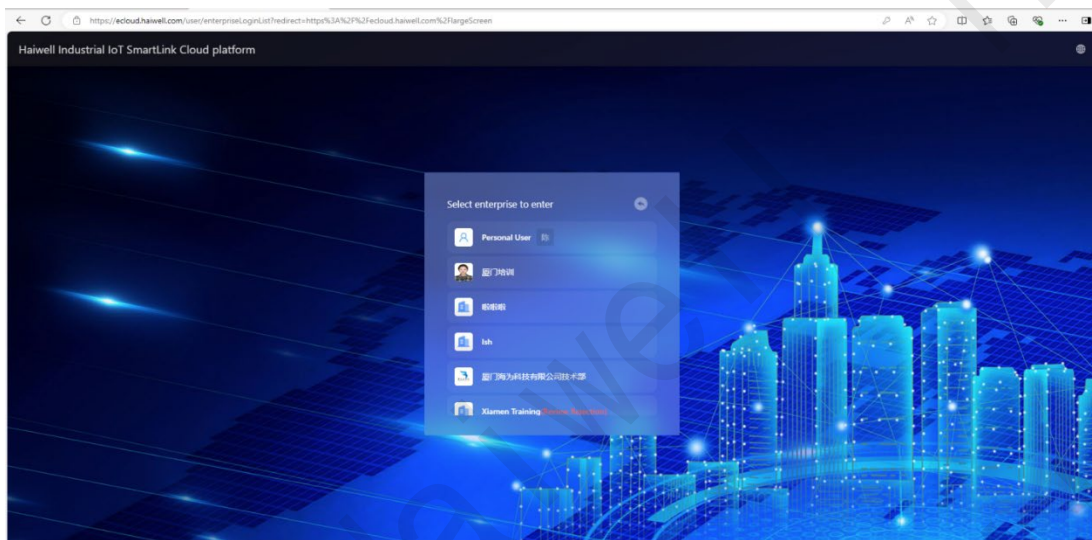



Figure124 Select Individual User

**Step 2:** In the device list, select the corresponding HMI and click  Enter device details.

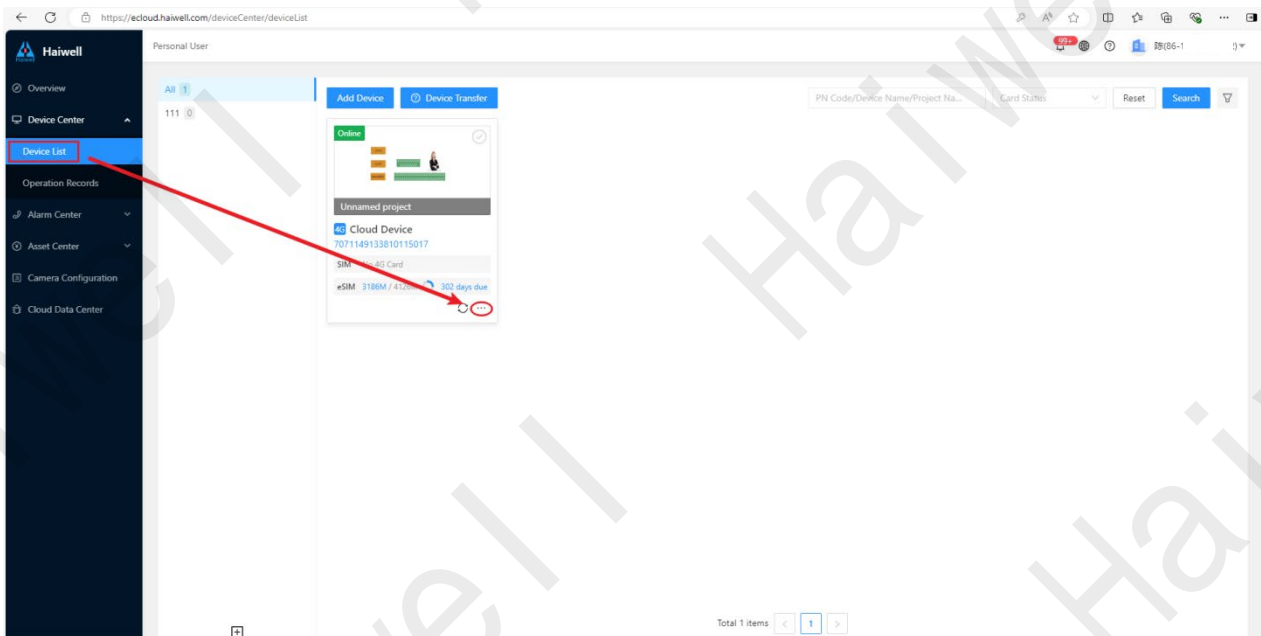

Figure125 Enter Device Details

**Step 3:** Click "Access Program" in the device details to access the HMI screen remotely.

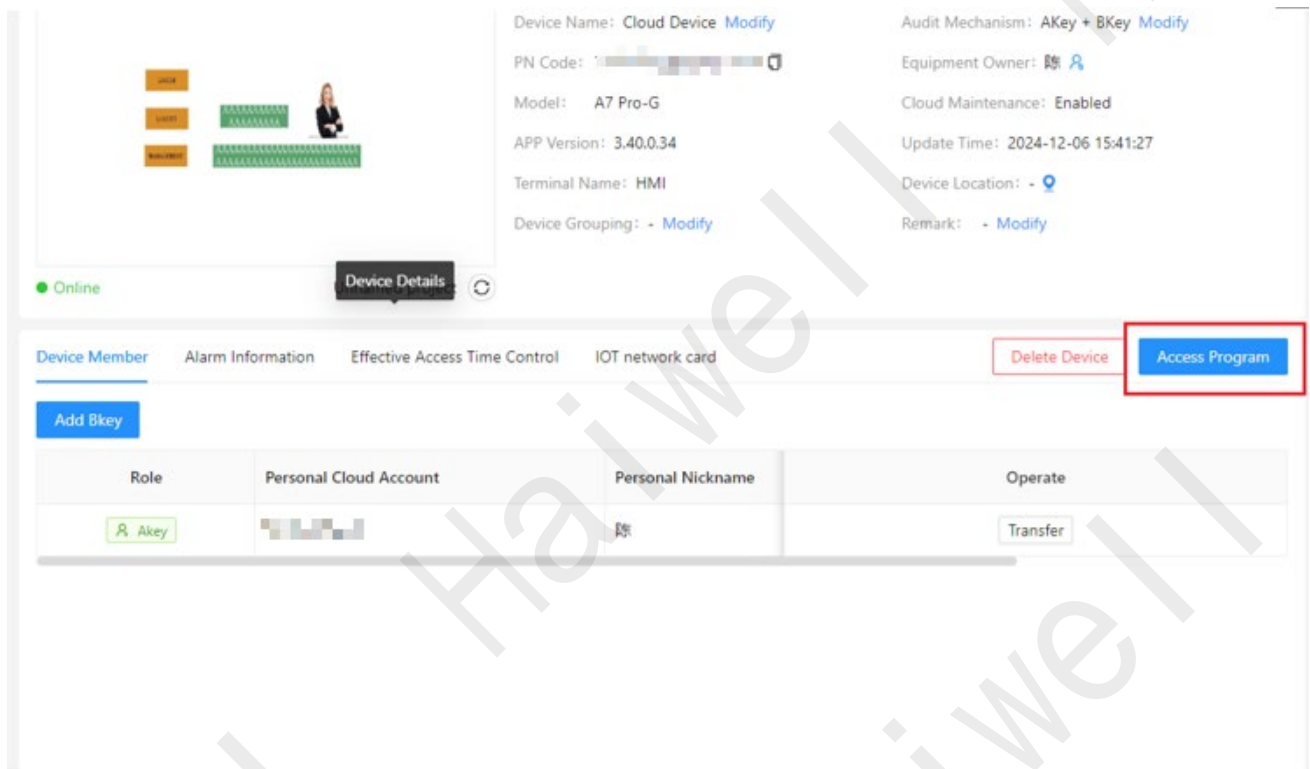

Figure126 Access Program

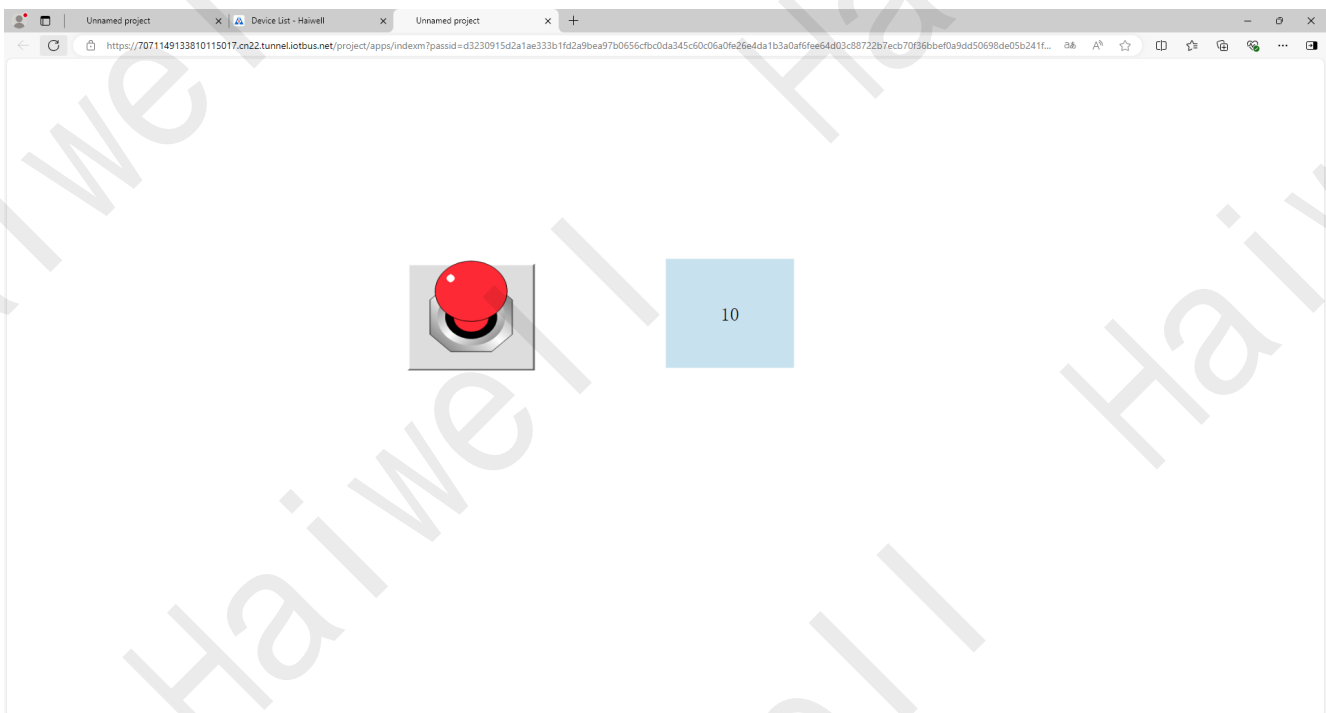

Figure127 Remote Access to HMI Screen

## 5.2 Remote Access on Mobile

Open the Haiwell Cloud APP or WeChat Mini program on your mobile phone, log in to the cloud device with the account password, select the corresponding HMI device, and finally click "Direct access".

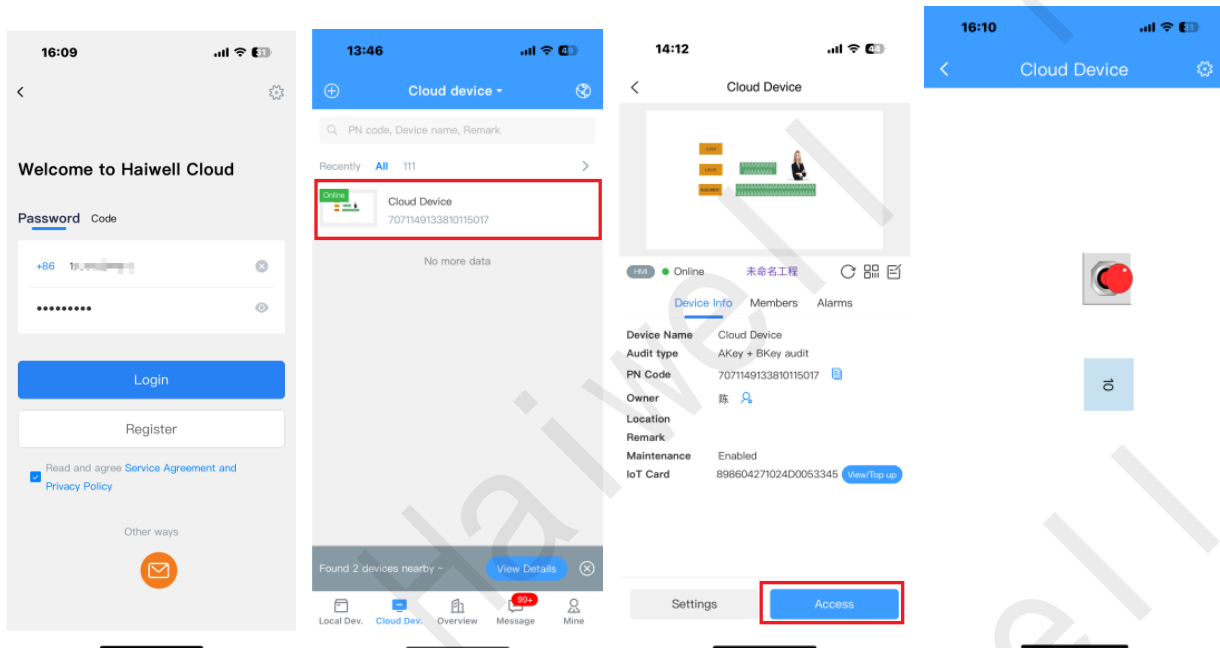

Figure128 Remote Access to HMI screen on Mobile Phone

## VII. Remote Transparent Transmission PLC

In this paper, Siemens 200 smart transparent transmission as an example, in the case of successful Ethernet communication between HMI and PLC, then perform the following steps to achieve the remote download of PLC function.

### 1. Modify the Computer Supply Network Segment

Open your computer Settings and click **【Change Adapter Options】**

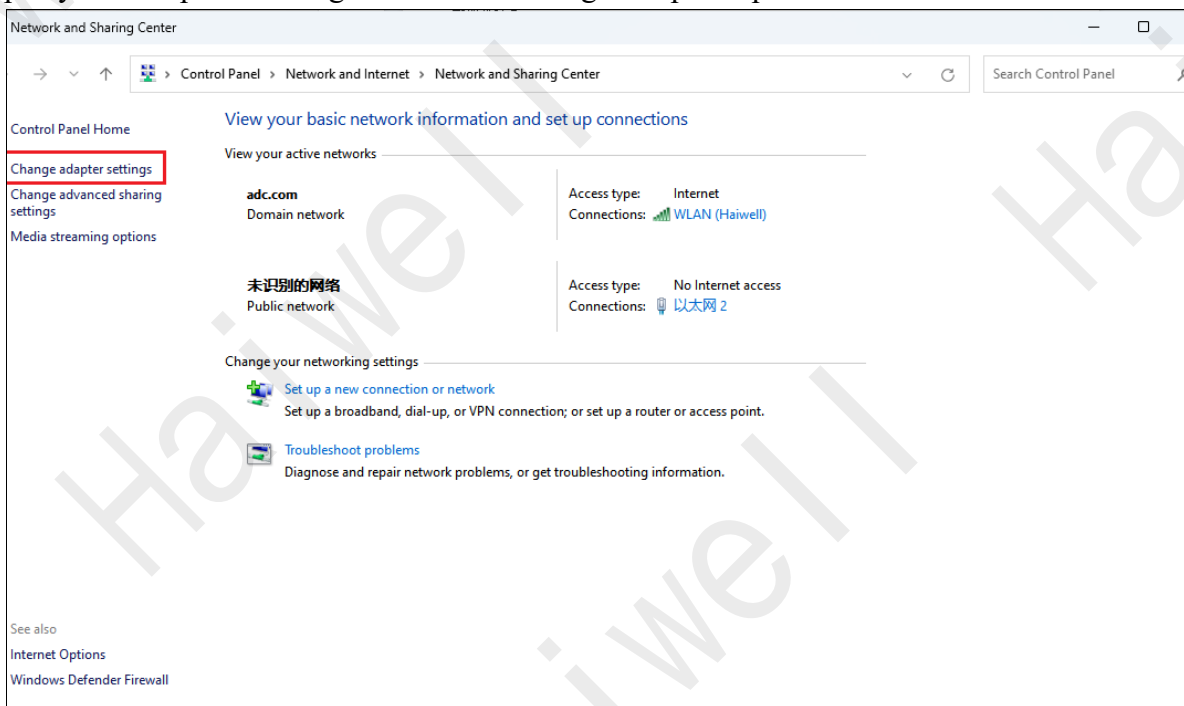

Figure129 Open Computer Settings

If the computer is supplied by Ethernet, check the Ethernet IP address segment to ensure that the Ethernet IP address segment is different from the PLC IP address segment. For example, if the PLC IP address is 192.168.14.133, the computer Ethernet IP address segment must be changed to other than 14.

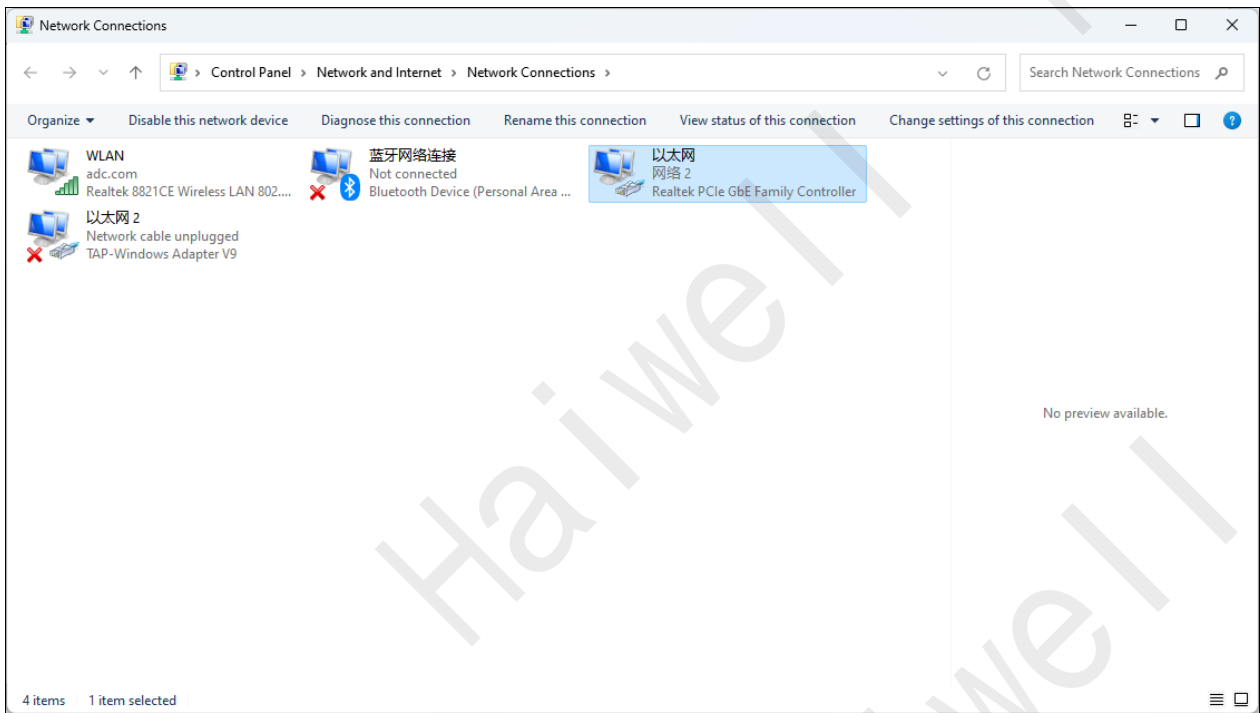

Figure130 Check the Supply Network Segment 1

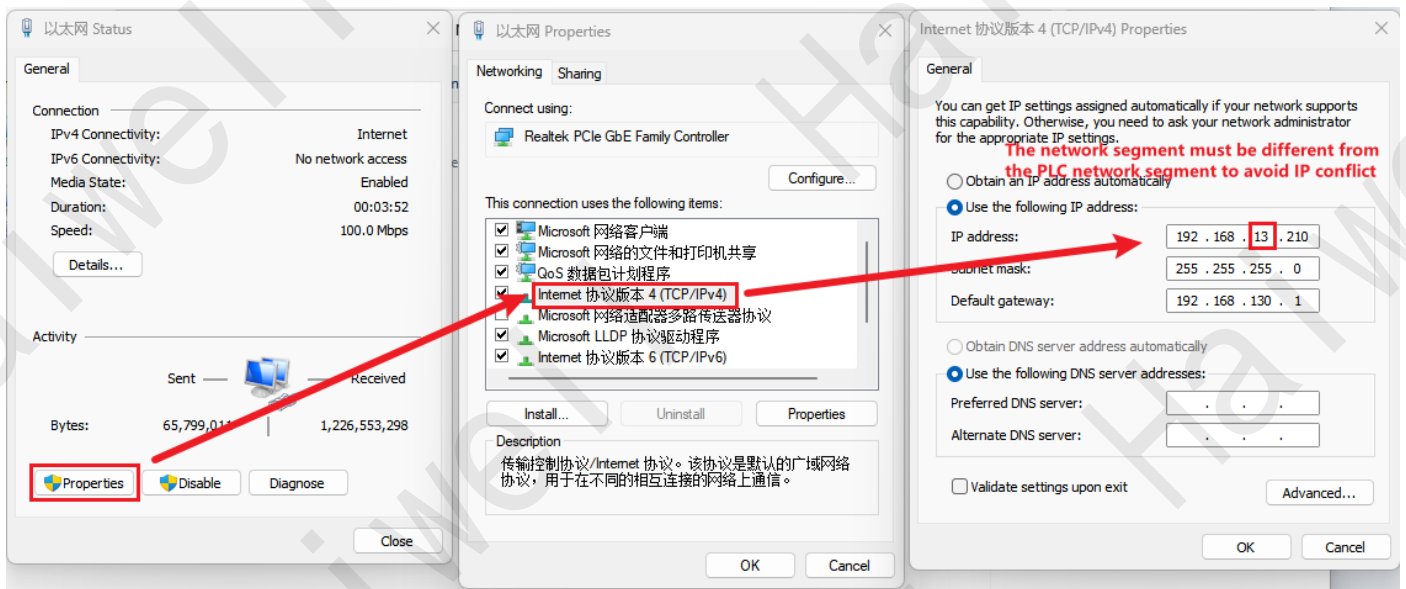

Figure131 Check the Supply Network Segment 2

**Note:** If the computer has WIFI function, the network mode can use WIFI first and then perform VPN transparent transmission operation.

## 2. Open the Device Management Tool

After the successful communication between HMI and Siemens 200 smart according to the previous project, open the configuration SCADA software - Tool - Device management tool, select Cloud Management, and carry out transparent transmission of the device.

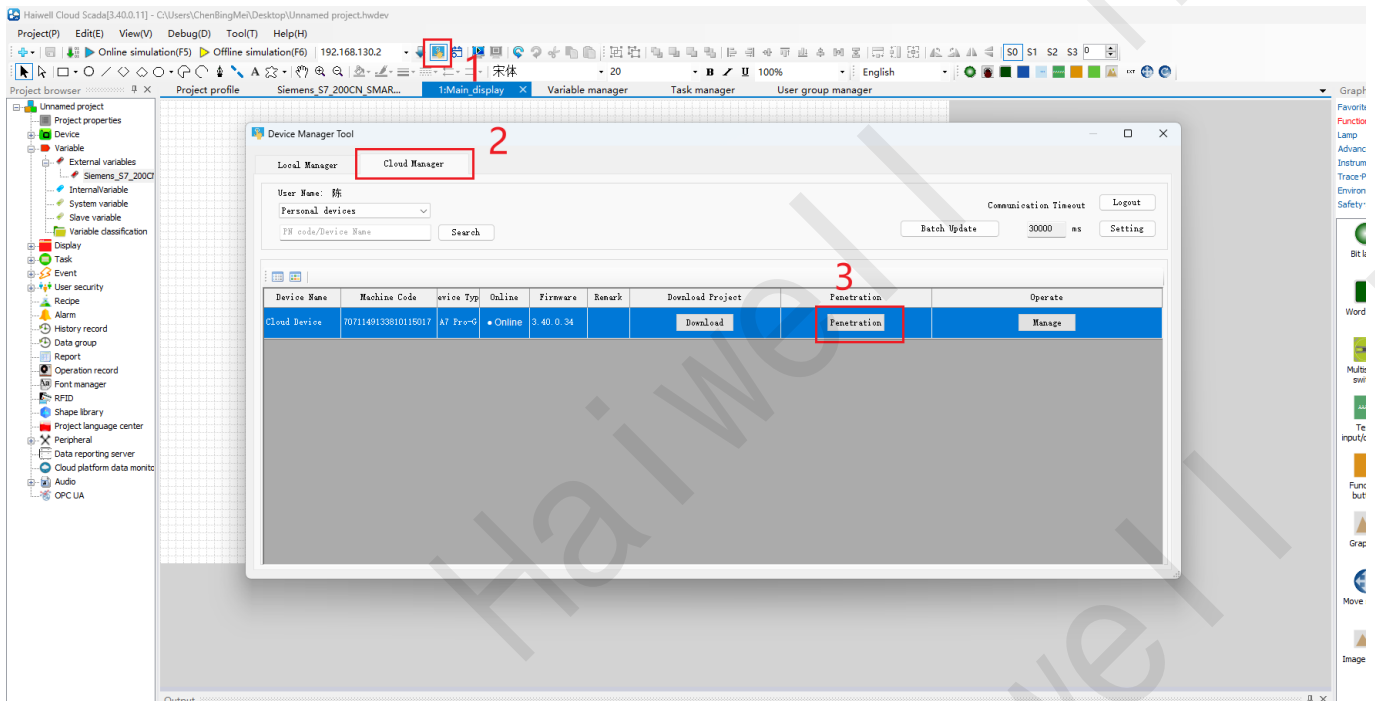

Figure132 Open the Device Management Tool

### 3. Connect Transparent Transmission Devices

Use the device management tool - Cloud Management to perform VPN transparent transmission, log in to the cloud account, select the corresponding Intelligent device - and connect the device.

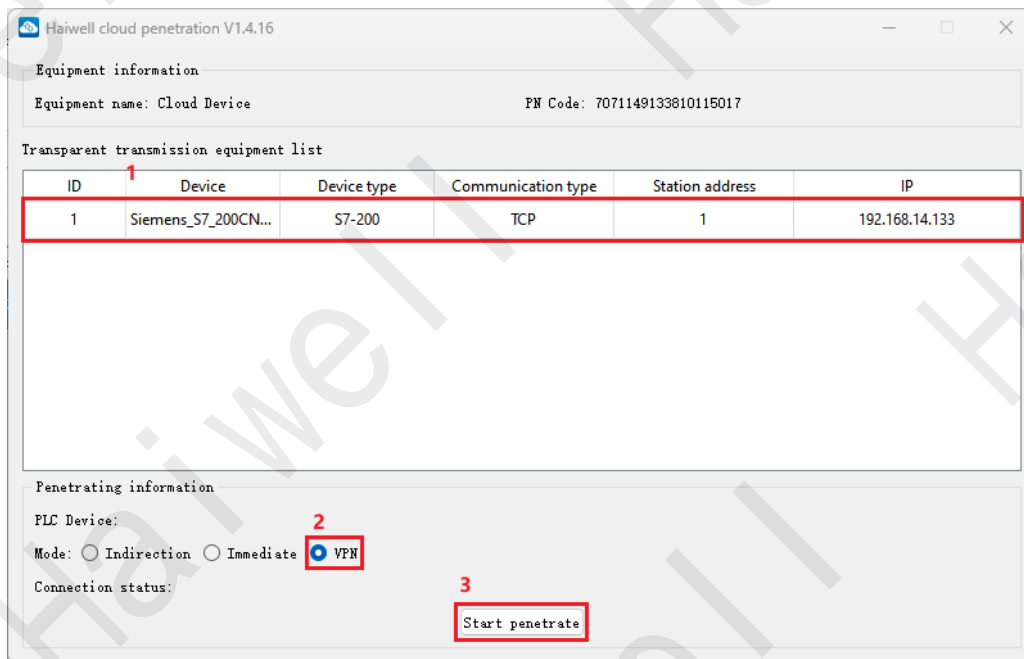

Figure133 VPN Connect the Transparent Device

After connecting the device - select the corresponding PLC, and the transparent transmission mode is the transit mode by default. In this paper, select VPN, click Start transparent transmission, and fill in the IP address to establish a virtual IP address through the touch screen.

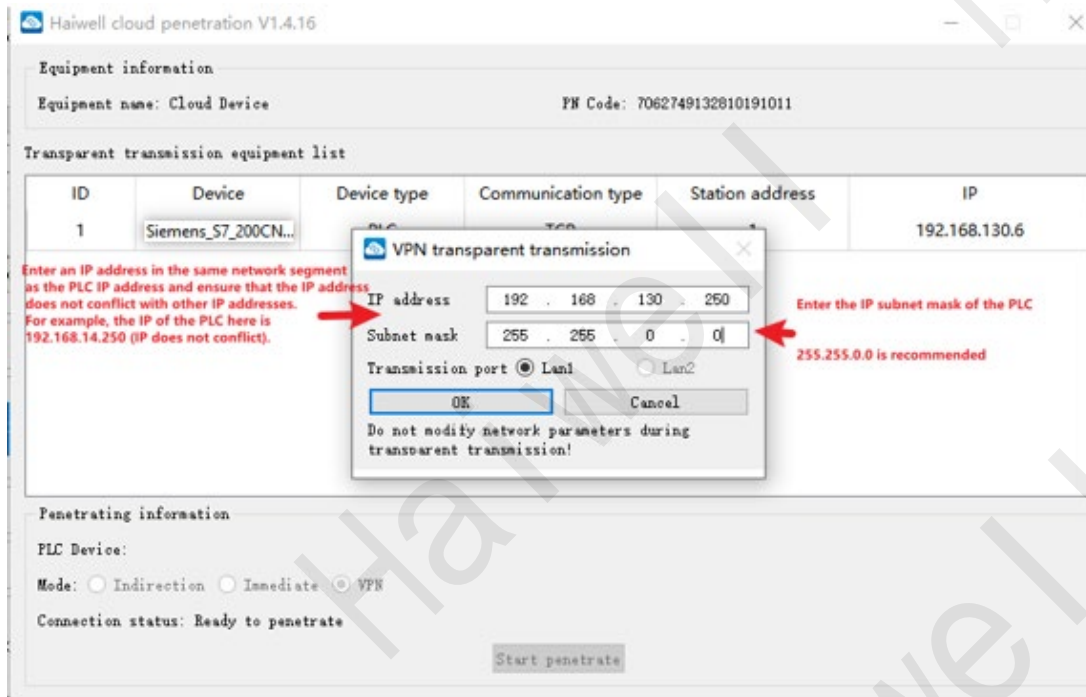

Figure134 VPN Transparent Transmission Fill Information

Note: Click after start pass through. The virtual IP address that needs to be set up here is not an IP address that is exactly the same as that of the PLC. The IP address is in the same network segment as the IP information of the PLC device that needs VPN transparent transmission, and there is no IP address conflict with the local area network where the PLC device is located. Subnet Mask Enter the subnet mask corresponding to the PLC IP address or 255.255.0.0, and click OK.

#### 4. VPN Status Check

After the preceding operations are performed and transmission through is enabled, you need to check the VPN status. Open your computer Settings and click **【Change Adapter Options】**.

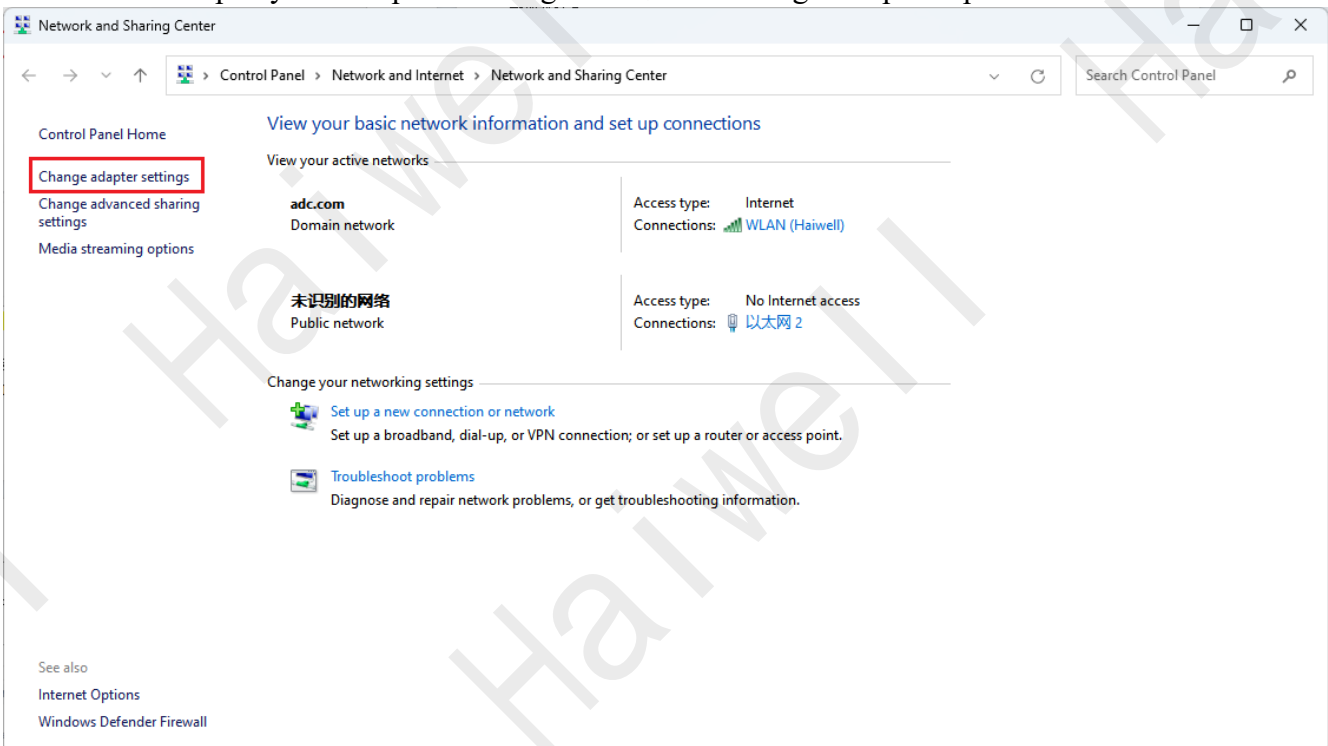

Figure135 Change Adapter Options

Locate the Ethernet (in this case, Ethernet 2) where the virtual network interface TAP-Windows Adapter V9 is located. Double-click the "Ethernet 2" interface.

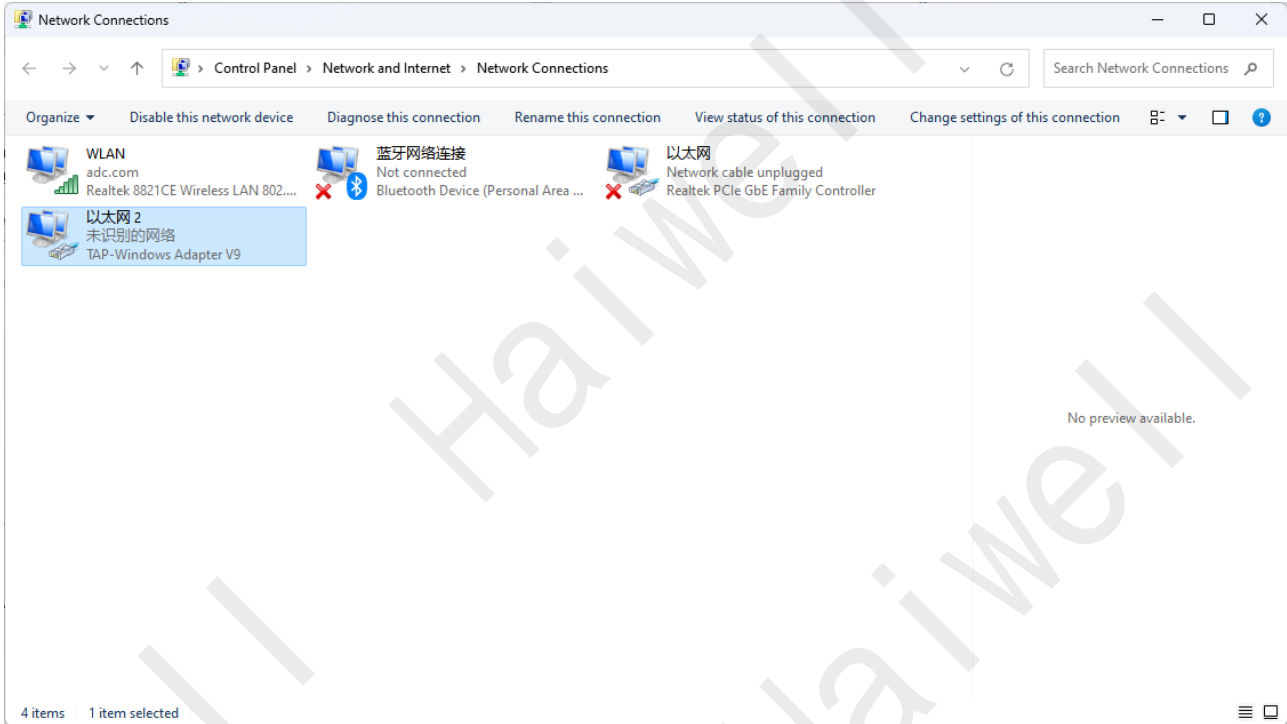

Figure136 Open the Virtual Network Card

Click **【Details】**, you can check the IPv4 address and IPv4 subnet mask information in the pop-up "Network Connection Details" page, and when the two are consistent with the VPN parameter Settings, you can start the transparent transmission PLC device.

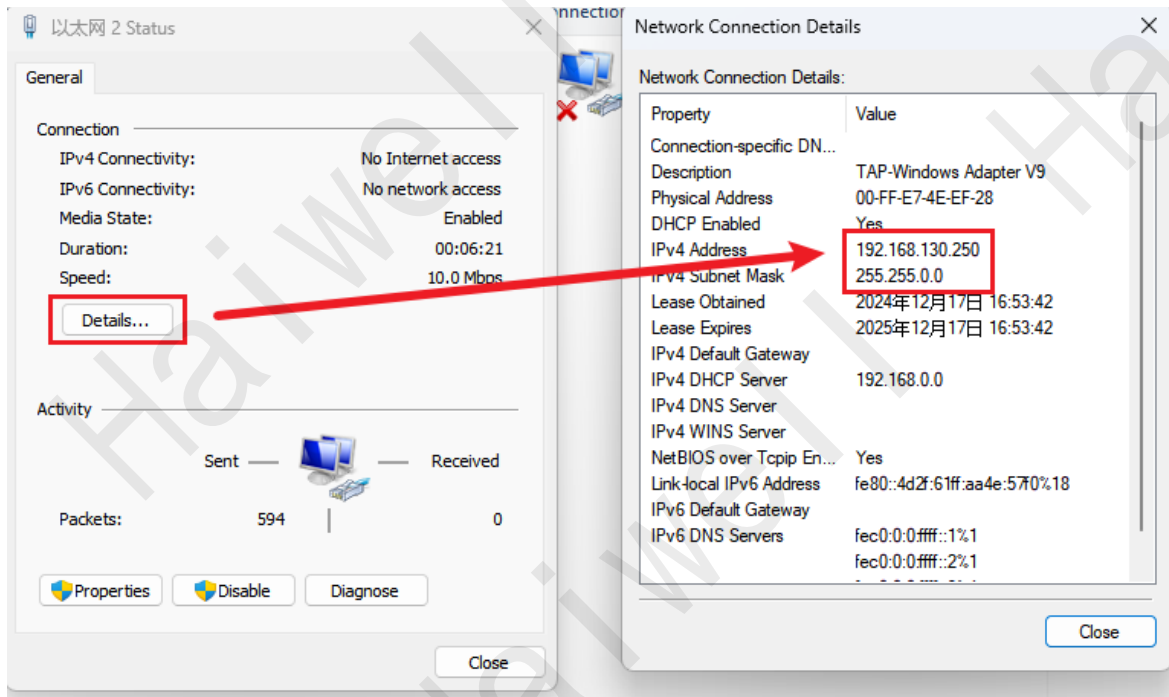

Figure137 Check the IP Address of the Virtual Network Card

**Note:** When the result of the query is: The generated TAP-Windows Adapter V9 network interface is

connected to an unidentified network, and its right-click status is displayed - The IPv4 address and IPv4 subnet mask in the details are consistent with the VPN parameter Settings, you can start transparent transmission of PLC devices.

(The preceding method is used to query VPN status in windows 10. In windows 11, you only need to click Settings > Network and Internet > Advanced Network Settings to query related network information.)

## 5. Transparent Transmission PLC

Open the Siemens programming software and click to go online. In the dialog box that is displayed, select the TAP-Windows Adapter V9 network interface driver. Click Find CPU, you can appear online PLC, if there is no CPU can be added manually enter the PLC IP address.

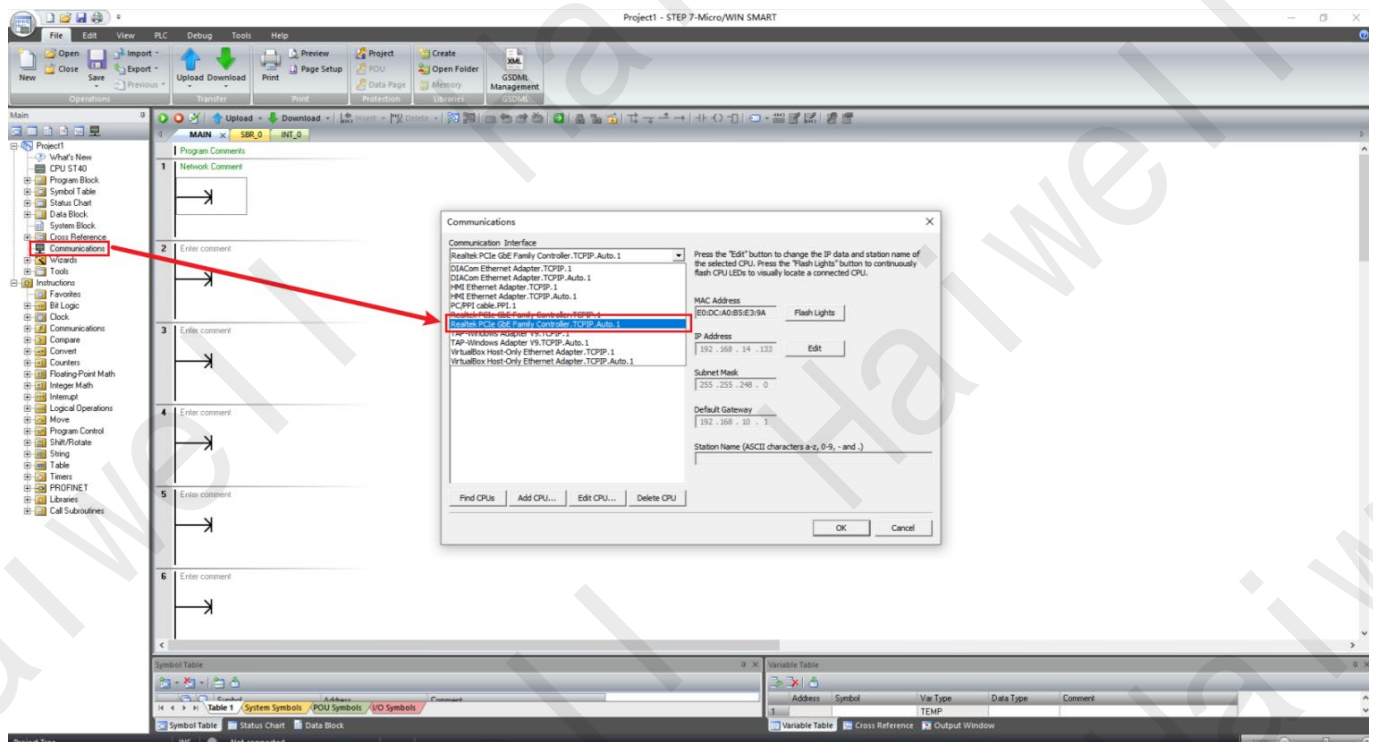

Figure138 Select the V9 Communication Interface

Select the IP device connected to the Siemens SMART PLC and double-click the corresponding IP to connect the PLC.

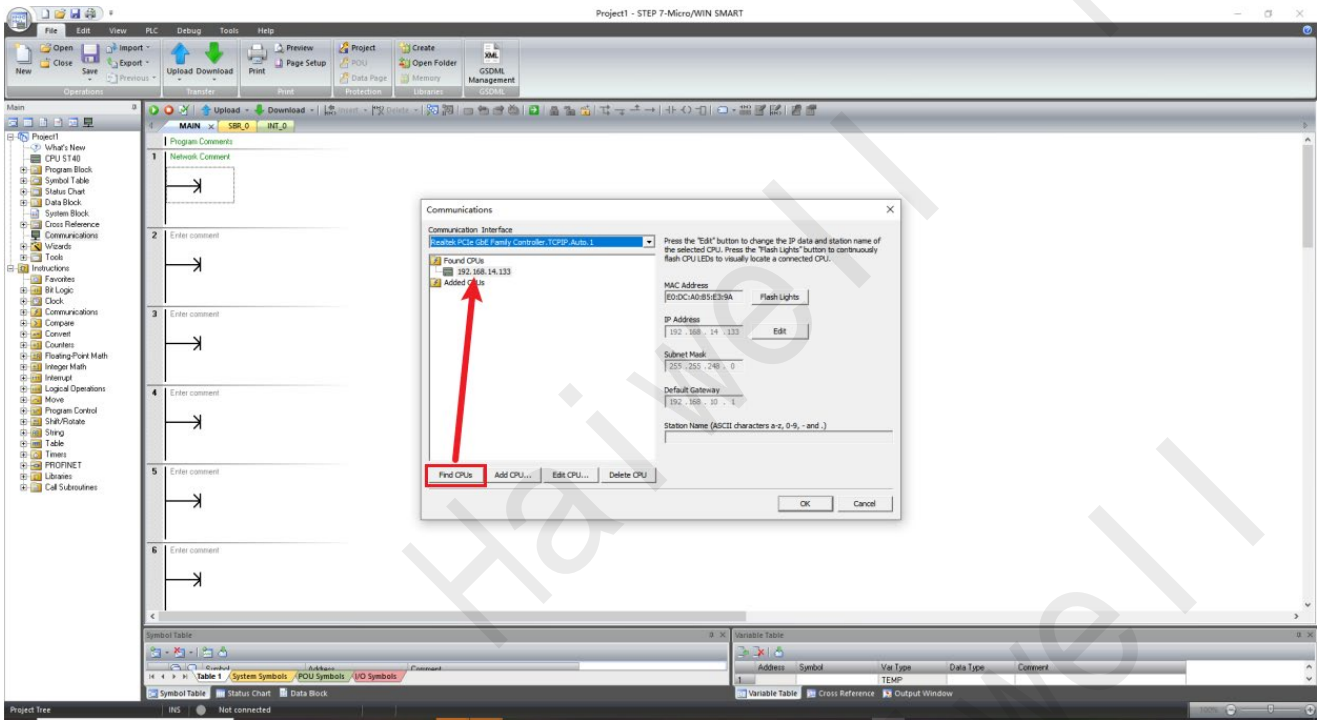

Figure139 Look Up CPU

After the connection is successful, you can see the connection status below, and you can download the PLC project.

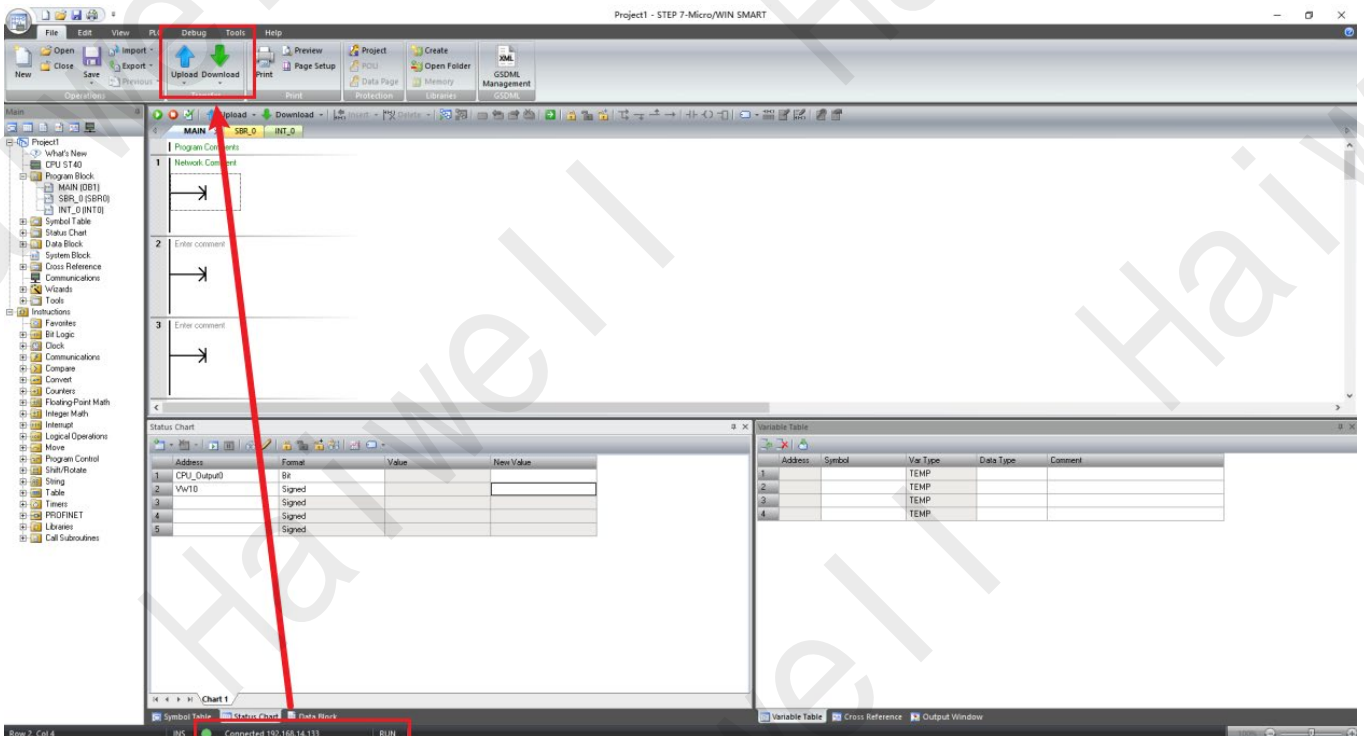

Figure140 Check Connection Status

Note: VPN transparent transmission support PLC and Haiwell products communication failure can also be normal transparent transmission;

VPN transparent transmission supports all PLC devices in the same LAN with transparent transmission set IP address parameters.

For other PLC transparent transmission tutorials, you can refer to Haiwell College - Study Zone - Special Column 5 (special column | Haiwell College).

## VIII. HMI Calibration

The optimized power on calibration mode ensures the precise correspondence between the touch point and the display position when the user uses the HMI, improves the accuracy of the operation, and can help adjust the deviation caused by environmental changes, hardware aging or replacement.

### 1. Enter Calibration Mode

**Method 1:** The HMI background Settings directly enter the calibration mode

Long press the upper right corner of the touch screen for five seconds to enter the background Settings, tap **【System Info】**, and then tap **【Start Touch Calibration】** to enter the calibration mode interface.

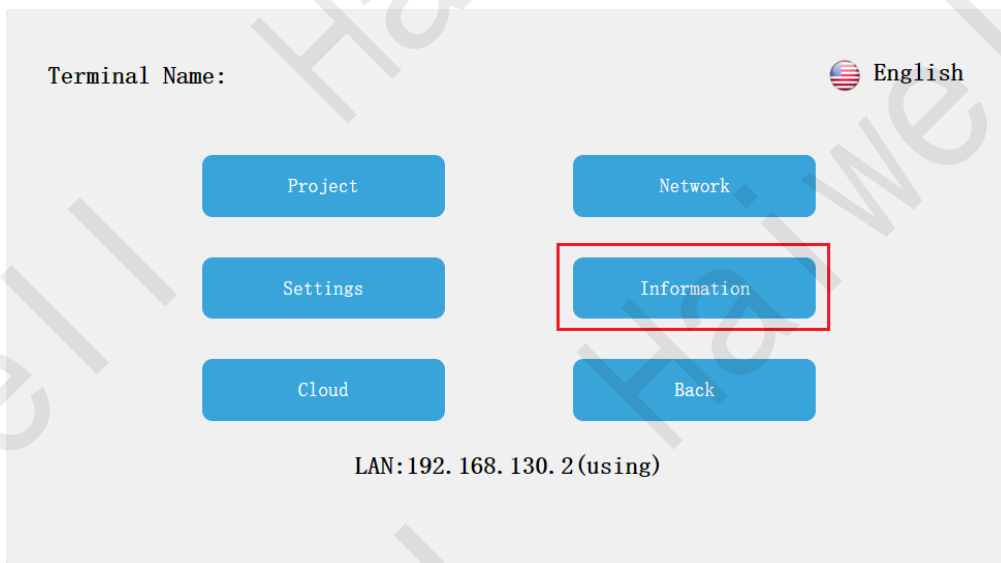

Figure141 Click System Information

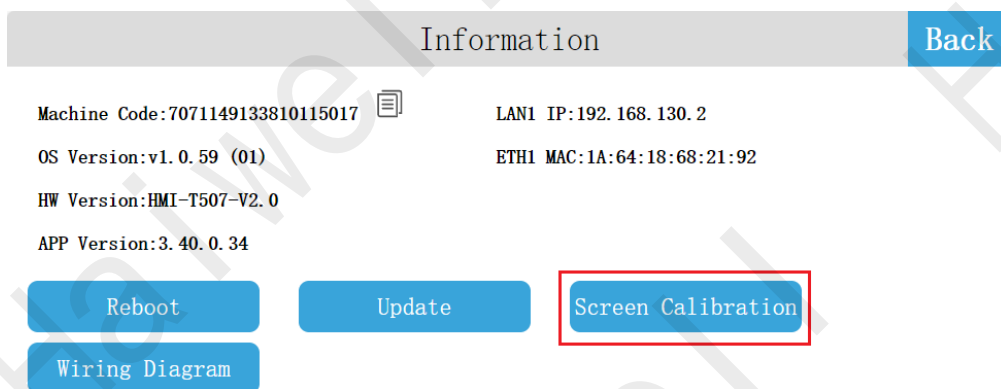

Figure142 Click to Initiate Touch Screen Calibration

The touch screen calibration has failed, it can be operated according to the following ways.

**Method 2:** Power off and restart the HMI. Enter the background Settings and recalibrate

**Step 1:** Go to background Settings

During the HMI startup stage, long press any position of the screen for 10s to automatically enter the background setting. If the HMI screen is held for less than 10s, the screen will be released, and the project screen will be directly entered.



Figure143 Press and Hold 10s to Enter Calibration 1

**Step 2: Enter calibration mode**

On the HMI background Settings screen, hold down 10s to enter calibration mode. If the user enters the background Settings through other methods, the HMI screen will not enter the calibration mode when long pressed.

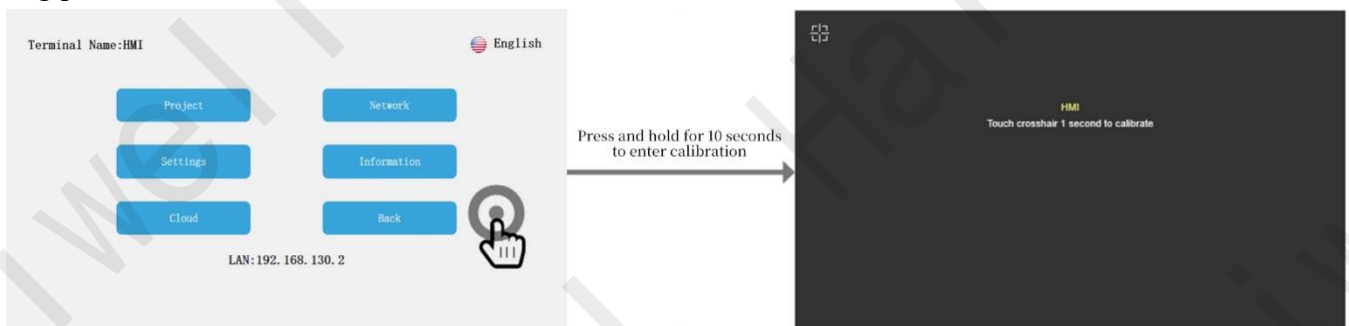

Figure144 Press and Hold 10s to Enter Calibration 2

**Method 3: Enter the HMI background Settings for the mobile APP**

Open the Haiwell Cloud APP on your mobile phone, and access the HMI device from the local device or cloud device. Take the cloud device as an example, enter the corresponding HMI device, and then click background Settings - System information - start touch calibration.

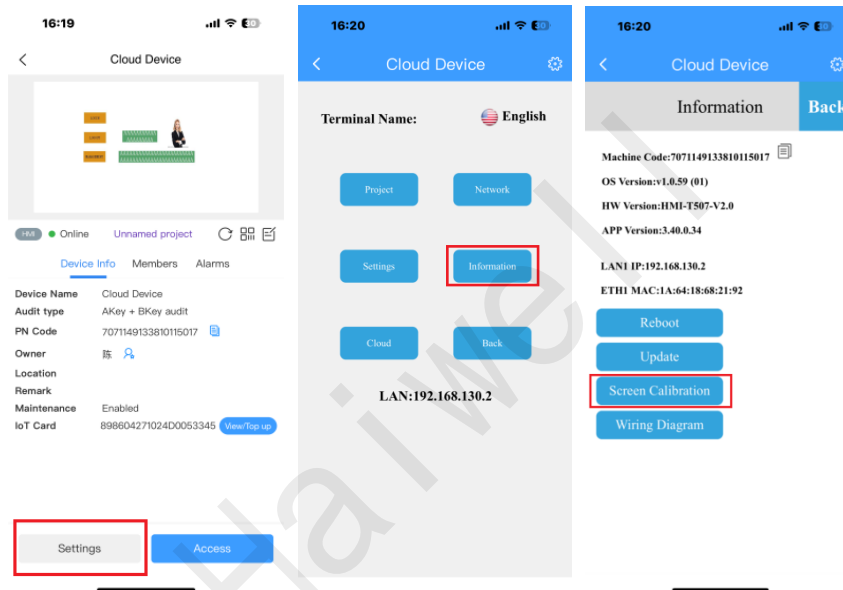

Figure145 The Phone Starts Touch Screen Calibration for the APP

**Method 4:** Computer LAN access HMI background Settings

If the HMI and the PC are in the same LAN and on the same network segment, you can enter the HMI IP/setting (for example, 192.168.13.202/setting) in the browser to access the HMI background Settings - System information - enable touch calibration.

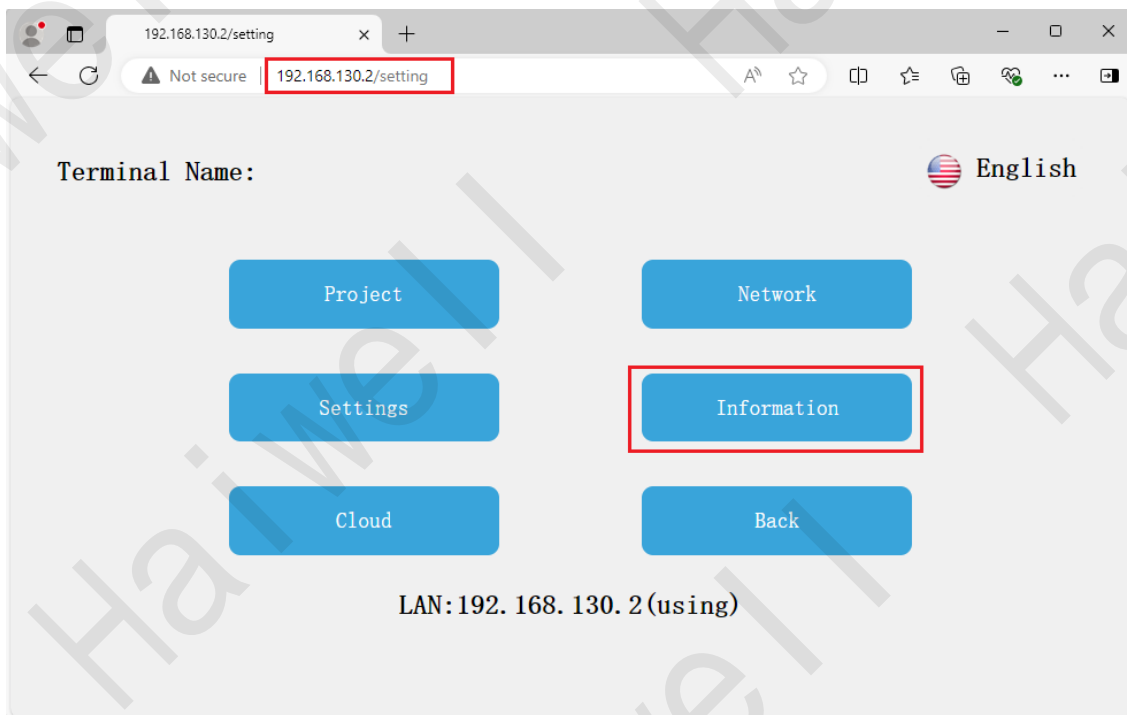

Figure146 LAN Activates Touch Screen Calibration 1

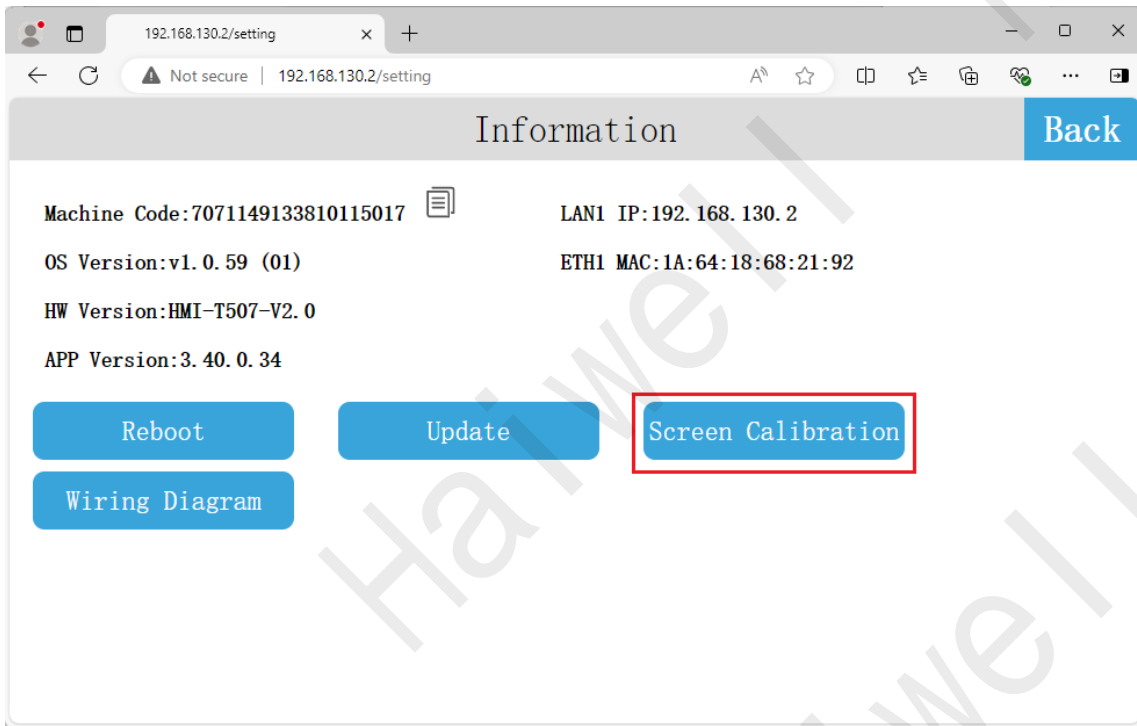



Figure147 LAN Activates Touch Screen Calibration 2

**Method 5:** Configure the software Local device/cloud device to start the calibration mode

If the HMI and the PC are on the same LAN and the network segment is the same, open the configuration software and click Device Management Tool , Local management or Cloud management. Select the HMI. Click Manage - Enable Calibration.

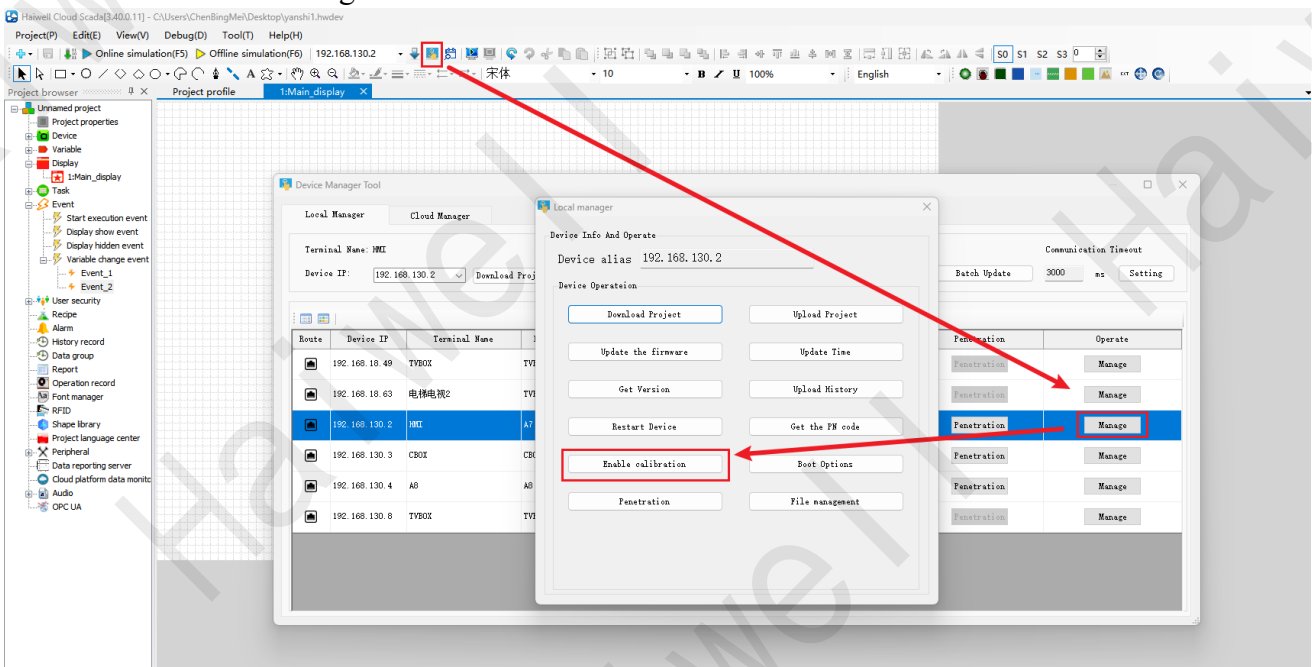



Figure148 SCADA Starts Touch Screen Calibration

## 2. Operation Calibration Mode Interface

In the Calibration Mode screen, the calibration cross symbol appears at the top left of the screen , Long press the cross for one second until you hear a drop release, enter the next calibration position, calibrate the touch screen of the device successively according to the five sequences of "upper left, upper

right, lower right, lower left, middle". Finally, the HMI will restart if the calibration is successful.



Figure149 Calibration Interface

## IX. Common Problem

### 1. What is the factory IP address of HMI?

The factory default IP address of the HMI is 192.168.1.112. To change the IP address of the HMI, see [V. HMI Settings -2. Background Settings -2.6 Network Settings](#).

### 2. How to download projects locally from HMI?

Local download project: If the HMI and the PC are on the same LAN and the PC network segment and HMI network segment must be the same, open configuration software - Device Management Tool - Local Device, find the corresponding HMI in the list, and click Download Project.

Local upload project: The HMI and the computer are in the same LAN and the computer network segment and the HMI network segment must be the same. Open the configuration software - Device Management Tool - Local Device, find the corresponding HMI in the list, select Management, enter the local manager, and click Upload Project. (The project disables uploading by default. If the project needs to set the upload function, open the configuration software, click Engineering - Project properties - Security Settings, and check Allow the upload project Settings upload password.

### 3. What is the password for uploading HMI factory demonstration project?

The A Series HMI Factory Demo project upload password is AHMI.

### 4. Is there any other way to enter HMI background settings besides on the screen?

#### Method 1: LAN Access

① PC: On the LAN, you can also access the HMI through a browser. The prerequisite is that the PC and HMI are on the same LAN and on the same network segment. Enter device IP address +/setting (for example, 192.168.11.123/setting) to enter the background setting screen.

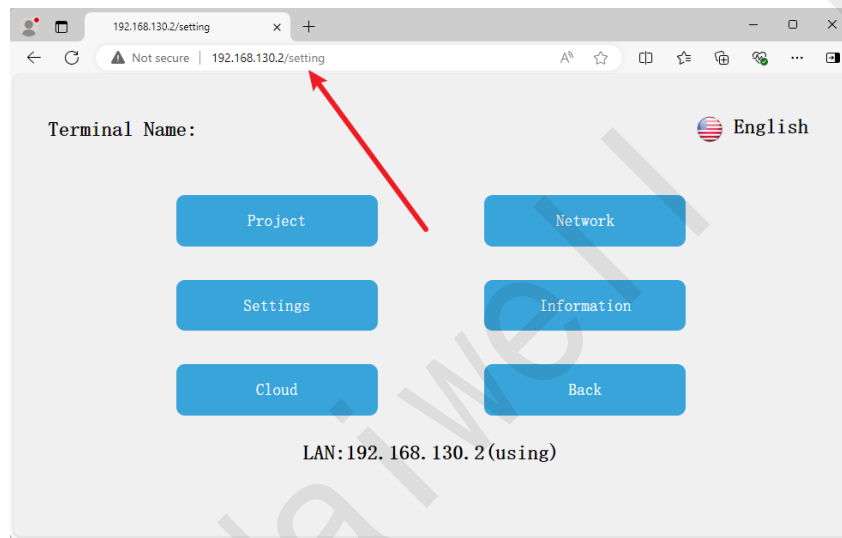



Figure150 Computer Browser LAN Access Background Settings

② Mobile terminal: If the HMI has a model with WIFI version, the mobile WIFI can connect to the hot spot of the HMI, and then open the Haiwell Cloud APP- Local device to find the HMI device. If the local device does not appear, you can find the HMI device in the upper left corner of the local device . Enter the IP address of the hotspot 10.5.5.1 to access the device page.

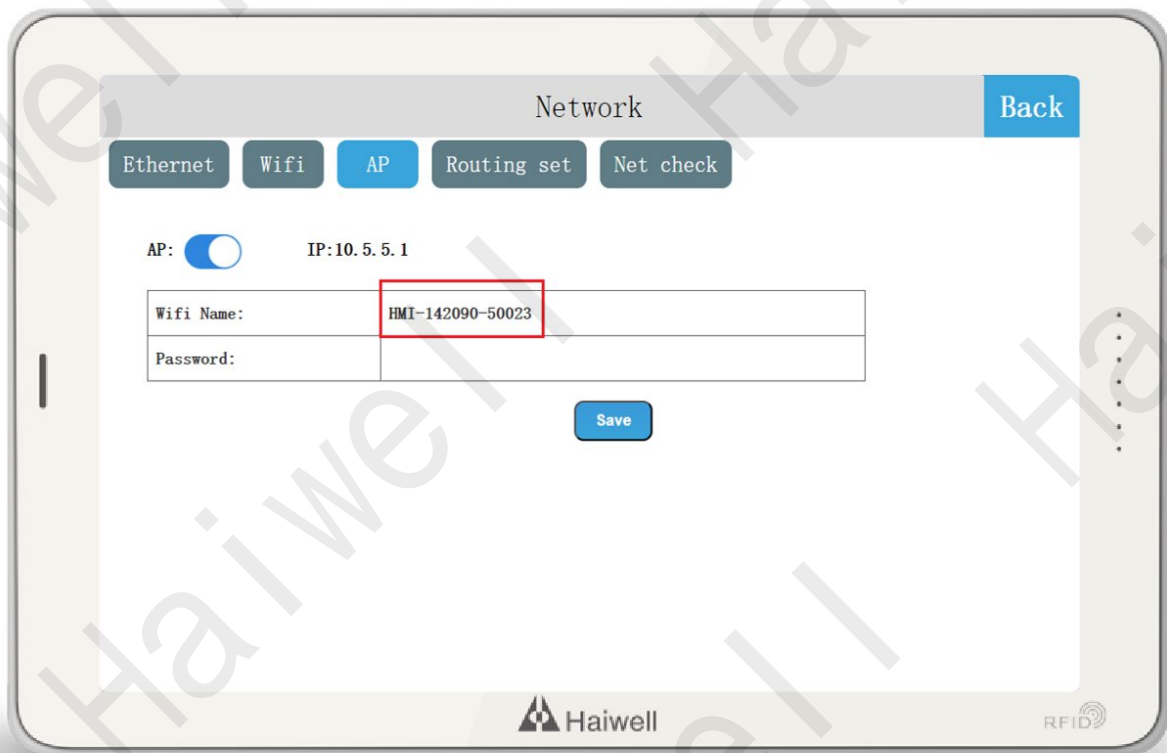

Figure151 Personal Hotspot Name

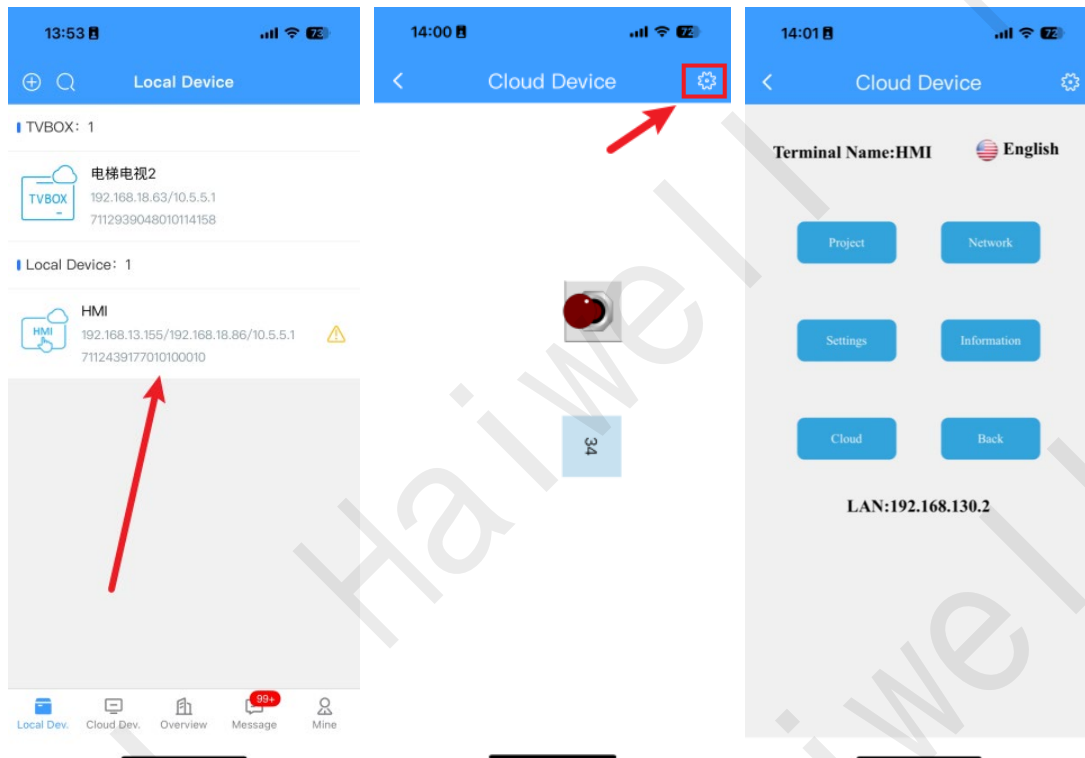

Figure152 Mobile LAN Access

**Method 2:** Access the project picture meta

In the advanced pixel of Haiwell Cloud configuration SCADA, pull out the "function button" of the pixel, double-click to enter the properties, select the function **【Enter system device】**, download the project to the HMI, click this button to enter the background Settings.

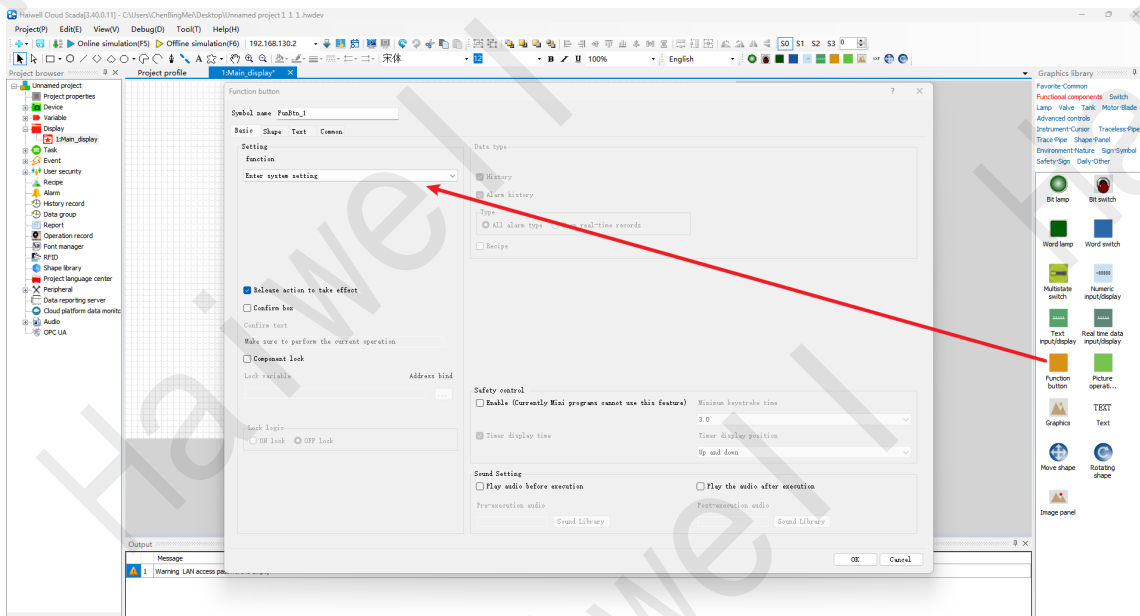

Figure153 SCADA Screen Enters the System Settings

**5. Can I download programs from HMI's USB and how can I download them?**

You can download it.

**Step 1:** Open the configuration software to enter the project, click the configuration software menu bar - Engineering - Generate USB flash drive run file, copy the USB flash drive run file to the USB flash

drive.

**Step 2:** Insert the USB flash drive into the USB port of the HMI, long press the upper right corner of the HMI display area to enter Background Settings - Local Settings - Project download - Select Generate USB flash drive running file to download successfully.

Refer to [V. HMI Settings-2. Background Settings-2.2 Project Settings.](#)

## 6. How to deal with unstable serial communication or offline communication reports between HMI and 485 devices?

### Communication failure:

**Step 1:** Check whether the communication cable is connected, if necessary, use a multimeter to measure whether the pin of the line is corresponding, and then check whether the communication protocol of the device (COM port, equipment station number, communication type, baud rate, data format, etc.) is configured in the configuration project.

**Step 2:** If the above check is correct, you can first use a third-party tool to communicate with the device, such as Modbus poll to check whether the communication can be successful. If not, the device may not be a non-standard device according to the standard Modbus protocol, and the communication may not be possible.

### Unreliable communication:

**Step 1:** The communication timeout period and subcontracting length of the equipment can be adjusted. It is recommended to set the communication timeout period to 1500ms and the subcontracting length to 10, as shown in the following figure.

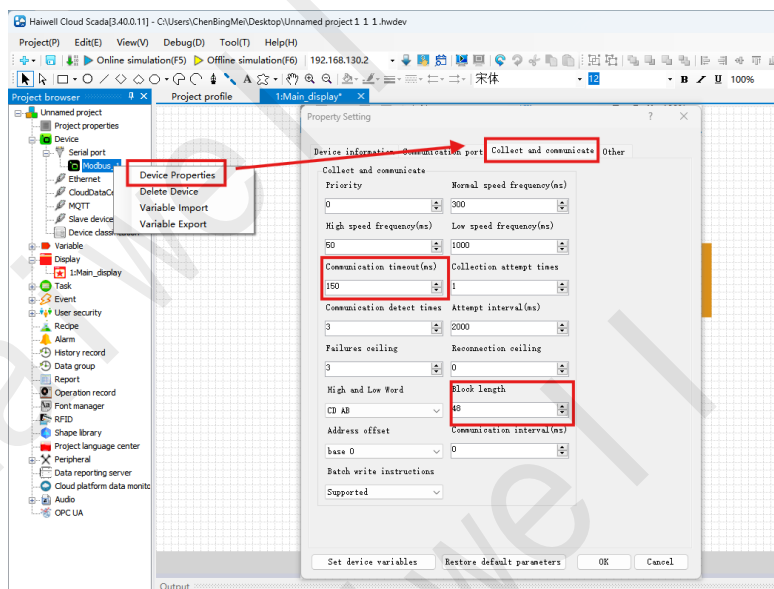

Figure154 Modify Collection Communication Parameters

**Step 2:** Do not place the power line and 485 line in a wire slot, and take anti-interference measures with shielded lines, magnetic rings, filters, etc.

## 7. How to deal with the normal communication flow meters, electricity meters and other instrumentation equipment, but the value read is not the same?

By default, the high and low byte order of the HMI device is CD AB, which needs to be adjusted according to the byte order of the device. If you do not know the byte order of the device, you can use the third-party tool Modbus poll to adjust the byte order for different values.

The configuration project modifies the byte order position of the device as shown in the following figure.

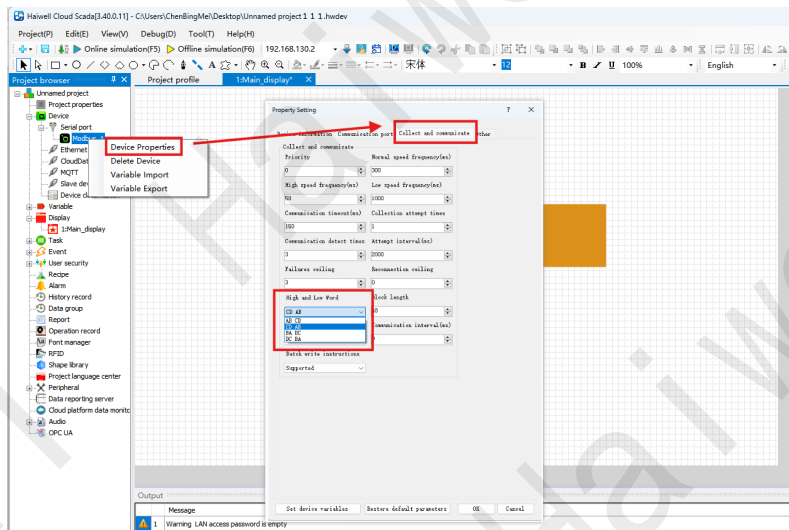



Figure155 Modify Collection Communication Parameters

## 8. How to unbind the machine owner AKey in HMI cloud settings?

**The AKey identity of the user is known and the login account is available:**

Mobile: open the Haiwell Cloud APP/ WeChat mini program, click the corresponding device in the cloud device to enter the device details, then click the  upper right corner to enter the edit device, and finally click Delete device. (If the device contains other users, delete the other users before deleting the device.)

On the computer side: go to ecloud.haiwell.com in the browser, click Device Center - Device list one by one after logging in, enter device details for the corresponding device on the right, and click Delete device.

## 9. How to troubleshoot if HMI cloud settings are not online?

**Step 1:** Go to the background of the device, click Network Settings - Network Diagnosis, enter the address cloud.haiwell.com to test whether the device can be pinged through to confirm whether it can connect to our server. If the fault cannot be rectified, perform the following steps to rectify the fault.

**Step 2:** Also in the background interface select the local Settings - other Settings in the current channel server click Settings, such as: the original Shenzhen server to switch to Qingdao, the original Qingdao server to switch to Shenzhen server.

**Step 3:** If the network is 4G, try to turn off the switch or set the DNS to 223.5.5.5.

## 10. How to deal with HMI displaying no service in the background when placing 4G card?

**Step 1:** Check whether the 4G card status, traffic balance, and Internet access status are normal. If the 4G card is a directional card, domain name binding is required. (Domain Name Reference Appendix)

**Step 2:** Place the 4G card when the HMI is powered off. Note that the chip face of the card faces the pin.

**Step 3:** Hold down the upper right corner of the HMI for 5 seconds to enter Background Settings - Network Settings -4G, turn on the 4G switch, and check whether information such as card number and signal strength can be read normally on the screen.

**Step 4:** Background Settings - Network Settings - Network Diagnosis, use the diagnostic tool to select www.google.com (Haiwell is cloud: Other countries or regions select Hong Kong, China or closer to the server channel).

## 11. How to handle HMI WIFI connection failure?

**Step 1:** Check whether the WIFI antenna of the HMI is properly installed. The antenna must be placed close to the signal source.

**Step 2:** The HMI requires a WIFI band of 2.4GHz.

**Step 3:** WIFI name and password do not contain Spaces and special symbols.

## 12. How to deal with VPN transmission failure to connect to PLC?

**Step 1:** Check whether the computer network segment is in the same network segment as the plc, if so, it is recommended to modify the computer network segment or replace another network mode (WIFI).

**Step 2:** Check whether the IP address of the virtual network card created by the computer firewall and antivirus software is correct.

**Step 3:** After the above steps are checked and correct, the computer can Uninstall the VPN tool, uninstall the file path: C:\Program Files\Open VPN, double-click uninstall. eve to uninstall the VPN. Then open the configuration software, the VPN transparent transmission operation will automatically reinstall the VPN tool, and finally follow the normal transparent transmission operation steps.

## 13. How to handle RTSP cameras that can display images but cannot be controlled?

The resolution of the camera is recommended to be 1920\*1080P or lower and the frame rate is 25fps or lower. If "Onvif verification failure or network exception" is reported, check whether the integration protocol of Hikvision is enabled first.

## 14. How to handle RTSP access to Hikvision camera and configuration camera example path not displaying?

Touch screen using RTSP visit Hikvision cameras such as configuration camera sample path or "rtsp://admin:1230192.168.1.1:554/h264/ch1/main/av\_stream" failing to show, Try new path:

"rtsp://account:password@Camera IP:554/Streaming/Channels/101".

## Appendix

### 1. Self-shopping IoT network card binding domain name collection

Serial Number	Agreement	Wildcard Domain Name
1	UDP	time.windows.com
2	UDP	*.ntp.org.cn
3	TCP UDP HTTP HTTPS	*.tunnel.iotbus.net
4	HTTP HTTPS WS WSS	*.haiwell.com
5	TCP UDP MQTT	*.iotbus.net
6	TCP UDP MQTT	*.cloud.haiwell.com
7	TCP UDP	47.107.224.237
8	TCP UDP ICMP	223.5.5.5