

Electro-Magnetic Flow Meter Transmitter Operation Manual (MYA-V3.0 Version)



CATALOG

1. Product Function Specification	PAGE 3
1.1 Base function	
1.2 Working conditions	
1.3 Connection type with sensor	
1.4 Transmitter outline dimension and type	
2. Transmitter Operation And Parameter Setting	.PAGE 6
2.1 Keyboard Definition and Display	
2.2 Transmitter Menu Structure	
2.3 Transmitter Parameter Description	
2.4 How to Setup The Parameter	
3. Wiring Diagram And Output Define	PAGE 16
3.1 Integral Type Wiring Diagram	
3.2 Separate Type Wiring Diagram	
3.3 Battery Power Flow Transmitter wiring Diagram (3.6V)	
3.4 Connection Between Transmitter And Sensor	
3.5 Frequency Output Mode	
3.6 Pulse Equivalent Output Mode	
3.7 Analog Output Mode (4-20Ma)	
4. Key Points of Attention	PAGE 19
4.1 Installation	
4.2 Power On And Preheat	
4.3 Set The Instrument Parameters Correctly	
4.4 Calibrate The Zero of Flowmeter	
4.5 Relationship Between Battery Life And Sensor Size	
5.Packing and Storage	PAGE 21
6.Appendix	.PAGE 21
Appendix 1: Flow Meter Transmitter Mode	
Appendix 2: Electromagnetic Flow Meter Mode (MYA)	
Appendix 3: Outline Dimension (Insert Electromagnetic Flowmeter)	
Appendix 4: Outline Dimension (Flange Type Electromagnetic Flowmeter)	
Appendix 5: RS485 Communication Address Table	

1. Product Function Specification

1.1 Base Function

Implementation Standards

《JJG-1033-2007 electromagnetic flowmeter》。

Suitable to Size of the Sensor (mm) :

1, 2, 3, 6, 8, 10, 15, 20, 25, 32, 40, 50, 65, 80, 100, 125, 150, 200, 250, 300, 350, 400, 450, 500, 600, 650, 700, 800, 900, 1000, 1100, 1200, 1300, 1400, 1500, 1600, 1700, 1800, 2000, 2200, 2400, 2600, 2800, 3000

Power Supply

Power supply : **85VAC --- 265VAC** or or **110vac to 420vac** or **24vdc** or **3.6v lithium battery**

The Velocity Range:

0.01 - 15 m / s, velocity resolution: 0.5 mm / sec

Requirement For Sensor And Excitation (AC and DC power supply type)

Excitation current can be set to 125mA、160mA、250mA

250mA excitation current is suitable to the resistance of two coil: 35~65Ω;

125mA excitation current is suitable to the resistance of two coil: 65 ~ 120Ω

excitation frequency: 25HZ; 12.5HZ, 6.25HZ, 3.125HZ

Requirement For Sensor (3.6V Battery power EMF TYPE)

The total resistance of two coil must less than 80 ohm ,if the total resistance is greater than 80ohm , then the flow rate is in stable.

Empty-Pipe Check And Full-Pipe Check

Automatic & continuous measure the condition of liquid and display the empty pipe and full pipe message.

do not need the full -pipe calibration and Avoid false alarm

Output Signal (AC and DC power supply type)

Current output: 4 to 20mA,load;resistance: 0~750Ω,Base deviation: 0.1%±10μA.

Frequency output: Frequency range is 100~5000Hz; Photoelectric isolation, isolation voltage: > 1000VDC;

Pulse equivalent output: user defined pulse width,automatic conversion to square wave at high

frequency ;Photoelectric isolation, isolation voltage: > 1000VDC;

Output Signal (3.6V battery power type)

3.6V battery power EMF type only have pulse output (or frequency output) and RS485 , have no another output signal .and the RS485 communcation is used to connect with GSM..

And the pulse output is without internal power , so you need provide the external 24vdc power , ortherwise have no pulse output

Alarm Output

Alarm output contact: **H-ALM** and **L-ALM** ; Photoelectric isolation, isolation voltage: > 1000VDC; Output driver: Maximum withstand voltage 36VDC, maximum load current 30mA.

3.6V battery power EMF type have no alarm output

Communcation

Communication : RS485 (standard)、HART(option)

MODBUS interface: RTU format, Physical interface: RS-485, Electrical isolation: 1000V;

HART interface: Support standard HART protocol

3.6V battery power EMF type have no HART option , only have RS485 communcation.

Language And LCD Display

English ,With LCD,display flow rate , total flow , velocity etc

three internal accumulator, record positive total flow and reverse total flow and net total

3.6V battery power emf type with backligh 。

Nonlinear Correction Function: Multi segment linear correction, suitable to variety of sensors

Automatic Zero Calibration Function

Quick Response, Response time of 0.3 seconds

Electrode Self-Cleaning Function

Protection

with lightning protection circuit design. High efficiency anti interference circuit, suitable for all kinds of harsh .

Grade of Protection: IP65 or IP68

1.2 Working conditions

Ambient temperature: $-20\sim+65^{\circ}\text{C}$; Relative humidity: $5\%\sim90\%$; Power: less than 10W (after connecting the sensor).

1.3 Connection type with sensor

Integral type and Separate type (converter is connected to the junction box of the sensor through the cable)

1.4 Transmitter outline dimension and type

According to the size of the sensor, we offer four kinds of transmitter housing, As shown in the figure below, please note: the PCBboard, software and menus and functions are be the same, only the size of housing and shape of the housing is different..

- **Integral type (MYAM1)**

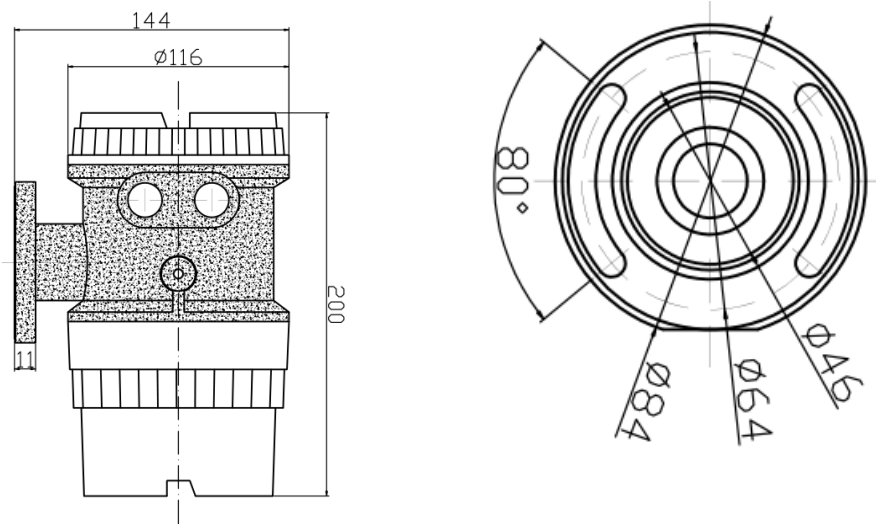

- **Integral type (MYAM2)**

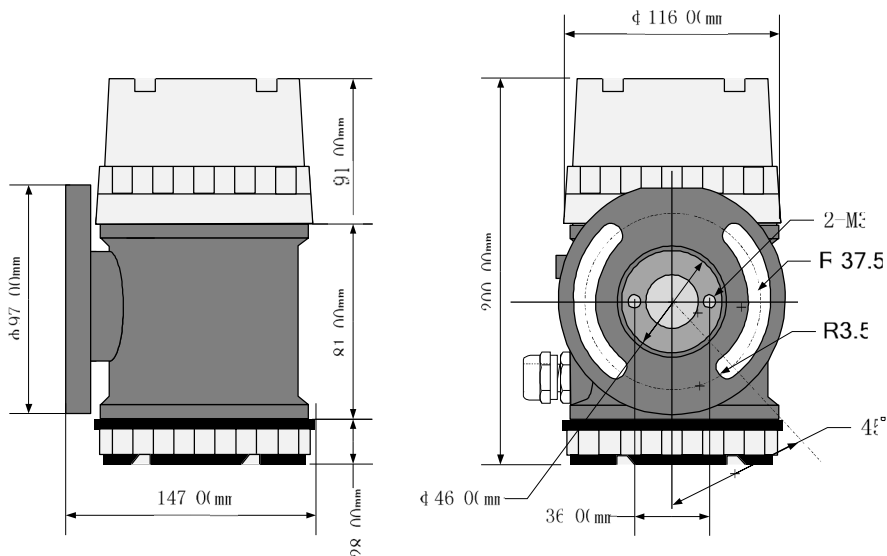

- Integral type (MYAS)

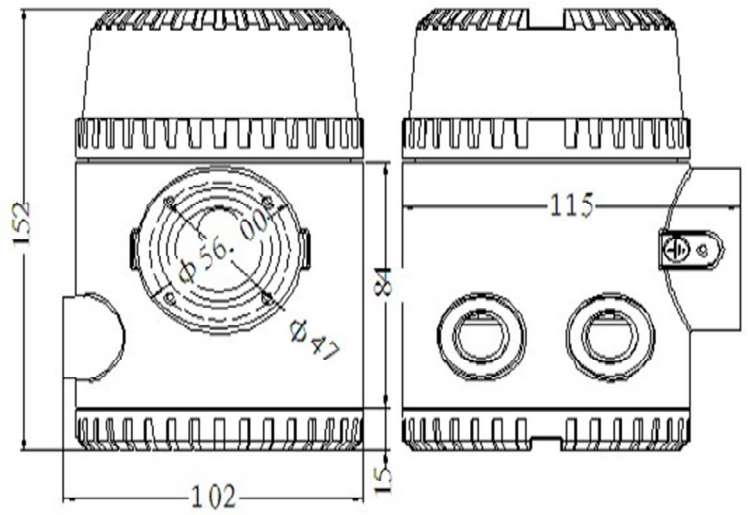

- Integral type (MYAB)

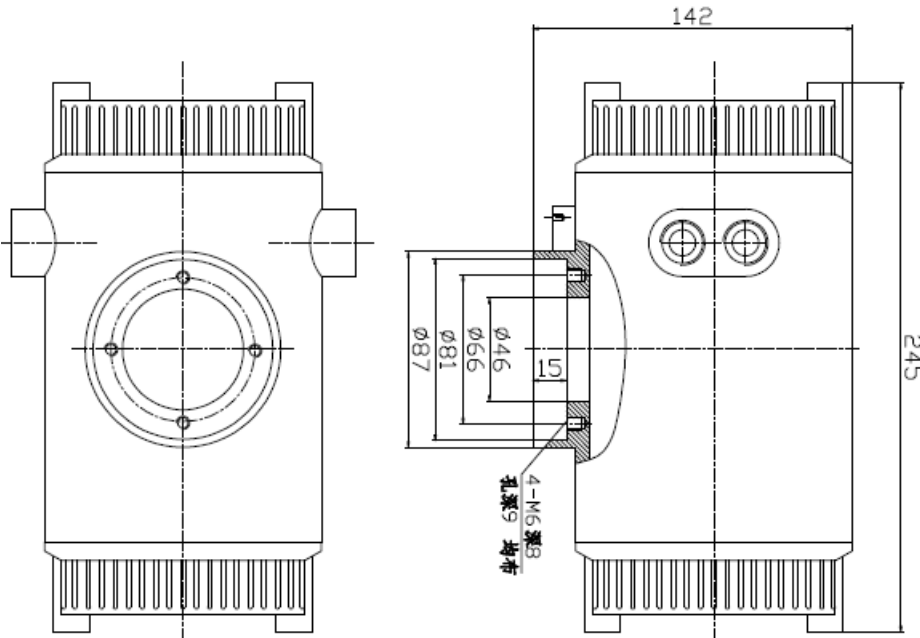

- Separate type (MYAR)

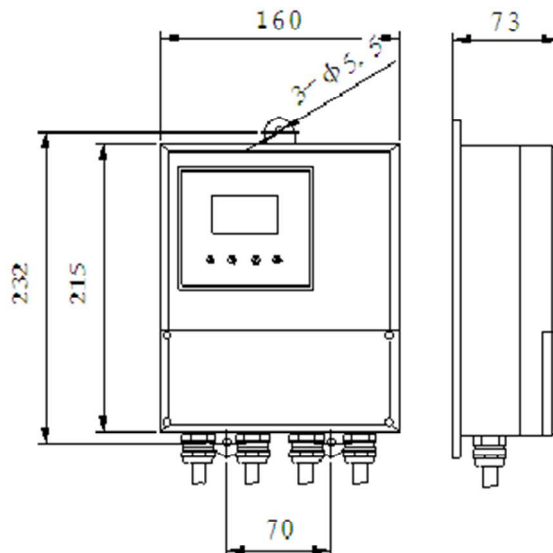

2. Transmitter Operation And Parameter Setting

2.1 Keyboard Definition and Display

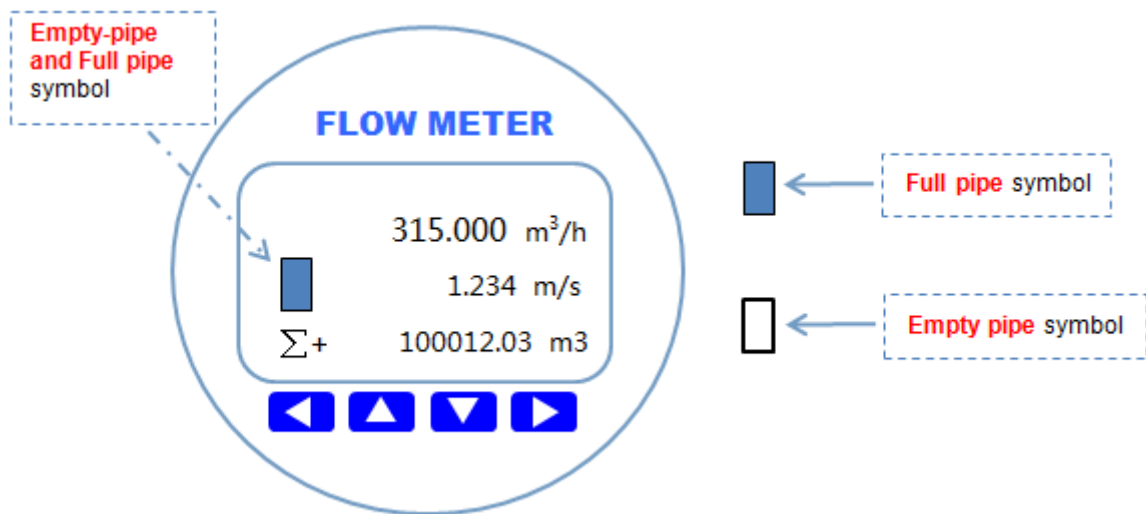

Figure A

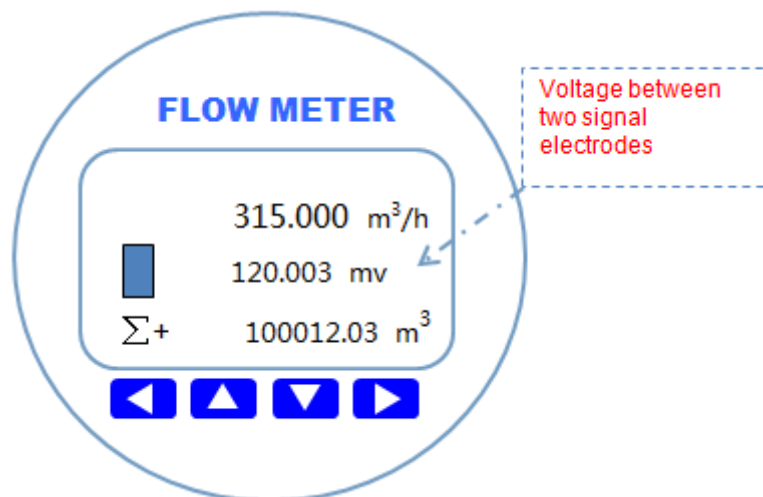

Figure B



Left shift, parameter setting confirmation key and exit sub directory key



fast descending button to go to <factory setup>, digital up key.



move up and down keys



move right, enter the parameter setting and exit key

Press  or , you can Switch between figure A and figure B

2.2 Transmitter Menu Structure

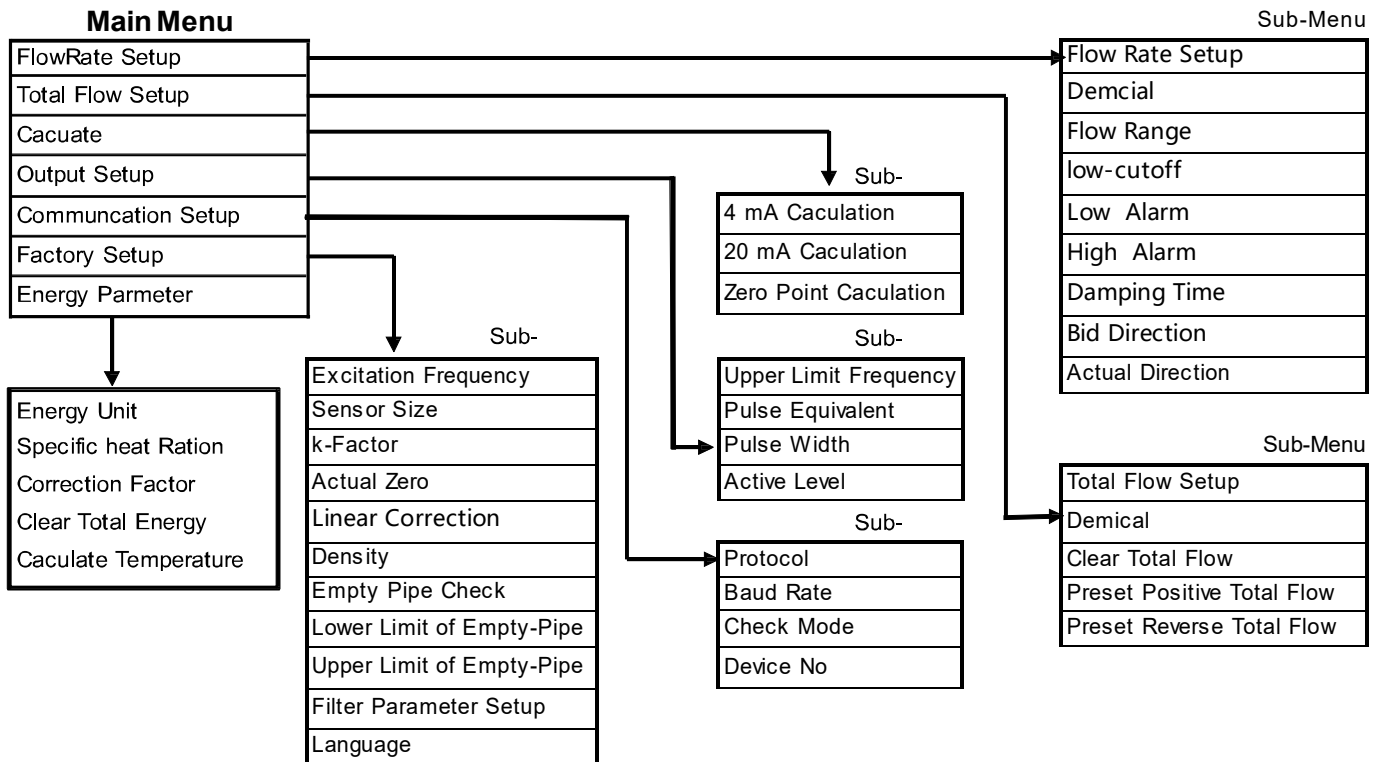

2.3 Transmitter Parameter Description

- Flow Parameter Setting

PV Unit	option: L/s L/m L/h m ³ /s m ³ /m m ³ /h USG/s USG/m USG/h Kg/s Kg/m Kg/h t/s t/m t/h default = m ³ /h ; define the unit of the flow rate L (liter), h(hour), t(ton), s(second) , m(minute)
PV Decimal	option: 0 1 2 3 , default = 1 define the decimal point position of the flow rate.
Flow range	Float point: 99999999.00-0.00 m ³ /h , default = 100.0 m ³ /h When the instantaneous flow rate reaches this set value, the output current is 20mA, Change this parameter will affect: current output, high and low flow alarm, etc.
Low flow cut-off	Float point: 9.90 ~ 0.00 % , default = 0.0 % The set value is a percentage.of flow range

Low alarm	Float point: 99.00 ~ 0.00 % , default = 0.0 % This value is a percentage of flow range. for example, if this value is setup to ten(10), then Equivalent to ten percent(10%) of flow range. If the Absolute value of instantaneous flow < (flow range × 10%),then the reansmitter willl oput the high alarm signal ,the contact of high alarm will close 。
High alarm	Float point: 99.00 ~ 1.00 % , default = 90.0 % This value is a percentage of flow range. for example, if this value is setup to ten(10), then Equivalent to ten percent(10%) of flow range. If the Absolute value of instantaneous flow > (flow range × 10%),then the reansmitter willl oput the high alarm signal ,the contact of high alarm will close 。
Damping time	Float point: 30.0 ~0.1 , default = 0.1 NOTE: for this type transmitter , no need to set damping time, flow measurement is very stable. So you can keep the damptime is default "0.1"。
Bid flow direction	Option: bid、reverse、 positive ; default = bid When set to positive, the reverse flowrate will not be displayed (display zero); When set to reverse, the forward flow rate will not be displayed (display zero); When set to Bi-directional,the positive and negative flow can be displayed。
Actual flow direction	Option: reverse、 positive; default = positive

- **Total Flow Setup:** Define the relevant parameters of the total flow。

Total flow unit	option: L(liter) m ³ USG Kg t(ton) , default value : m ³ define the total flow unit
Decimal	option : 0 1 2 3 , default value : 1 define the decimal point bit of the total flow value
Clear total flow	option: No Yes , default value : No Clear the total flow Note: if the "Flow Over!" alarm information, please timely clear or preset the total flow to avoid affecting measurement.
Positive total preset	Float point: 999999999 ~ 0.00 m ³ , default = the current total flow. After setting this value, the current total flow will be covered by this set value.
Reverse total preset	Float point: 999999999 ~ 0.00 m ³ , default = the current total flow After setting this value, the current total flow will be covered by this set value.

- **Calaculation:** Ajust analog output and zero value of flow meter

4mA caculate	<p>Float point: 5.0~3.0 , default = 0.0</p> <p>After you go to thie item, please use the Precision current meter to measure the current output value . if this result is not 4.0mA, then input the actual value which measure to this position .then The instrument will automatically complete the calibration operation .</p>
20mA calculate	<p>Float point: 21.0 ~19.0 , default = 0.0</p> <p>After you go to thie item, please use the Precision current meter to measure the current output value . if this result is not 20.0mA, then input the actual value which measure to this position .then The instrument will automatically complete the calibration operation .</p>
Calculate zero	<p>option: No / Yes , default = No</p> <p>When the fluid is static in the pipeline and completely filled with the pipeline, the zero value is equal to the voltage difference between the two signal electrodes of the electromagnetic flowmeter.</p> <p>Note: after the implementation of zero calibration, if the zero value is high, please check the sensor。</p> <p>In general, the zero value can not exceed 2mV. If the zero value is more than 2mv , then the accuaracy of the flow mter is not ok .</p> <p>If the zero value is high, but the sensor has no quality problem, you can reduce the excitation frequency to reduce the zero value.</p>

- **Pulse Output Setup:** setup the parameter of pulse output or frequency output

Upper frequency limit	<p>Floating point: 5000.0 - 100.0 Hz , default = 2000.0</p> <p>Output Frequency (Hz) = flow rate (m3/h) ÷ Flow range (m3/h) × Upper frequency limi (Hz)</p> <p>For example , the flowrate is 100m3/h, and the flow range is 200m3/h , and the “upper frequency limit “is set to 2000HZ, then this time , the output frequency is 1000HZ</p> <p>Note: if use the “frequency output” then must set “Pulse equivalent”=0</p>
Pulse equivalent	<p>Floating point: 9999.0 – 0.0 , default = 0.0</p> <p>When the pulse equivalent = 0.0, then output frequency signal</p> <p>When the pulse equivalent > 0.0, the pulse output is determined by the "pulse equivalent".</p> <p>The “pulse equivalent” unit is “liter per one pulse”</p>
Pulse width (ms)	<p>Floating point: 1000.0 ~ 0.0 ms , default = 0.0</p> <p>When this value is "0", the duty cycle of the output pulse is 1:1</p>

Active	<p>option: Low (Active low) High (active high) default = Low (Active low)</p> <p>this parameter is related to the "pulse width". When set to “ Low ” , the set value of the pulse width is used as the pulse width of the pulse output low level. When set to “high” , the set value of the pulse width is used as the pulse width of the pulse output high level. In general, this parameter does not need to be set.</p>
--------	--

- **Communcation Setup:** setup RS485 communcation parameter

Communication Protocol	<p>option: Modbus-RTU Modbus-ASCII default: Modbus-RTU</p>
Baud Rate	<p>option: 1200 2400 4800 9600 19200 38400 default = 19200 Note: Please set the baud rate \geq 9600</p>
Data Bit	<p>option: 7 8 , default = 8 Note: if use RTU protocol, prohibit to choose “7”</p>
Check Mode	<p>option: None , Odd , Even default = Even</p>
Device No	<p>data: 247 ~ 1 , default = 1</p>

- **Factory Parameter Setup:**

Password 052500 . Setup the key parameters ,

Excitation Frequency	<p>Option: 25HZ, 12.5HZ .6.25HZ . 3.125HZ Default value = 6.25HZ If the sensor size is greater than DN500, select 3.125HZ; If the sensor size is less than DN500, select 6.25HZ; If the inductance of the sensor is very small, you can choose 25HZ If the zero value is high, but the sensor has no quality problem, you can reduce the excitation frequency to reduce the zero value. If the flow rate is not very stable, you can try to reduce the excitation frequency.</p>
Sensor Size	<p>option: 1, 2, 3, 6, 8, 10, 15, 20, 25, 32, 40, 50, 65, 80, 100, 125, 150, 200, 250, 300, 350, 400, 450, 500, 550, 600, 650, 700, 800, 900, 1000, 1100, 1200, 1300, 1400, 1500, 1600, 1700, 1800, 2000, 2200, 2400, 2600, 2800, 3000 mm default value = 50 mm</p>

k-factor	<p>Floating point: 9.9000~0.0100 , default = 0.1</p> <p>This parameter is determined when the real flow calibration is carried out. This parameter is only related to the sensor, which indicates the characteristic value of the sensor.</p> <p>New Sensor K = the old Sensor K × (flowrate of the Calibrated flowmeter ÷ actual flow rate)</p> <p>After you finished the test by water , then need setup the final K-fator at here.</p>
Actual Zero	<p>default: 0.0 , unit: mv.(votage)</p> <p>When the fluid is still in the pipeline and completely filled with the pipeline, the zero value is equal to the voltage difference between the two electrodes of the electromagnetic flowmeter.</p> <p>Note: after the implementation of zero calibration, if the zero value is high, please check the sensor.</p> <p>In general, the zero value can not exceed 2mV. If the zero value is more than 2mv , then the accuaracy of the flow mter is not ok .</p>
Linear Correction	<p>The correction range: the default value is 0 ~ 2m/s (refers to the scope of the role of nonlinear correction value)。</p> <p>default value =0.0 mv</p> <p>Correction value = (calibrated flow - standard table flow) / standard table flow * is currently calibrated voltage</p>
Density	<p>Float point: 999999~0.1 kg/m³ , default = 1000.0 kg/m³</p> <p>When you need to use the quality unit, set the exact density!</p> <p>If the unit is Volume unit,then this item have no any affect.</p>
Empty Pipe Check	<p>option: enable or prohibit , default = enable</p> <p>If you select “prohibit”, then the flowmeter transmitter does not carry out empty-pipe detection. then Even if there is no water, it may be show the flow rate.</p>
Lower limit of empty pipe (as shown in right picture)	<p>Float point, default = 4100</p> <p>MYA type EMF transmitter can measure the resistance between electrodes automatically. For three electrode flowmter or four electrodes flow meter or the flowmeter with ground ring, If the pipe is fully filled with water, then the resistance value is about the 2200 ,because of the different conductivity of the fluid, this value may be somewhat different, and For separate type flow meters, the length of the cable also affects this value. In fact, most of the fluid , this value is basically between 2000-3300 when the Fluid filled pipe. And when the pipe is empty (no water), then the value will become to about 4800 to 5200, So we setup the “Lower limit of empty-pipe” to 4100. And this is type value.</p>

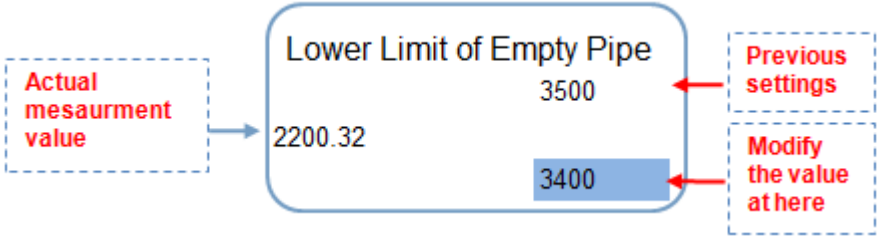
<p>Lower limit of empty pipe (as shown in right picture)</p>	<p>If you setup the “Lower limit of empty-pipe” to 4100, the meaning is that the flowmeter determines the current state to “empty pipe(no water in pipe)” when the actual measurement value >4100. If the actual measurement value <4100, then the flowmeter determines that the pipe is filled with liquid.</p> <p>The actual measurement value is appeared in the left of this menu. In some cases it may be possible to change this setting.</p> 
<p>Upper limit of empty pipe</p>	<p>Float point, default = 5800</p> <p>MYA type EMF transmitter can measure the resistance between electrodes automatically. For two electrode flowmeter or the flow meter which is not well connected to ground, If the pipe is fully filled with water, then the resistance value maybe >6000 ,because of the different conductivity of the fluid, this value may be somewhat different, and For separate type flow meters, the length of the cable also affects this value. And when the pipe is empty (no water), then the value will become to about 4800 to 5200, So we setup the “upper limit of empty-pipe” to 5800. And this is type value.</p> <p>If you setup the “upper limit of empty-pipe” to 5800, the meaning is that the flowmeter determines the current state to “empty pipe(no water in pipe)” when the actual measurement value <5800. If the actual measurement value >5800, then the flowmeter determines that the pipe is filled with liquid.</p> <p>The actual measurement value is appeared in the left of this menu. In some cases it may be possible to change this setting.</p>
	<p>For all electromagnetic flowmeter, whether it is the two electrode or three electrode or with ground ring. MYA Transmitter determines the “empty pipe(no water in pipe)” according to <u>actual measurement value</u> and “upper limit empty-pipe” and “lower limit empty-pipe”.</p> <p>If “lower limit empty-pipe” <= <u>actual value</u> <= “upper limit empty-pipe”, then the flowmeter determines to “empty pipe(no water in pipe)”.</p> <p>If <u>actual value</u> < “lower limit empty-pipe” ,then “full-pipe(filled water)”</p> <p>If <u>actual value</u> > “upper limit empty-pipe”, then also “full-pipe”</p>

Filter-parameter setup	Filter time: default =0, option : 0、 1、 2 Note: In the normal state, the filtering time is “0”, and meet the requirements of the corresponding time for 0.3 seconds. If the flowrate is very instable , and the sensor is ok ,and this instability condition is caused by the fluid, then you can change the ”filter time” to “1”.
	Filtering threshold: default =1, option: 1、 2、 3、 4、 5

- **Energy Parameter Setting:** Define the relevant parameters of the energy meter, and please note: this menu will appear when you purchase the energy meter.

Energy unit	option: GJ/h , Kc/h , KW default: GJ/h
Heat capacity ratio	Float point: 0.000 - 10.0 , default =4.2
Correction factor	Default = 1.0
Clear total energy	option: No Yes , default = No if select the “yes”, then clear the total energy value to zero
Calculate temperature	The temperature measuring circuit of the converter is calibrated by using high precision precision resistance box.

2.4 How to Setup The Parameter

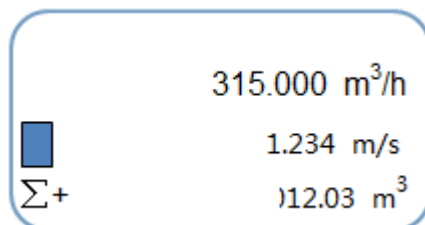

Figure 1: flow rate display interface

press  to parameter setup menu, As shown in Figure2:

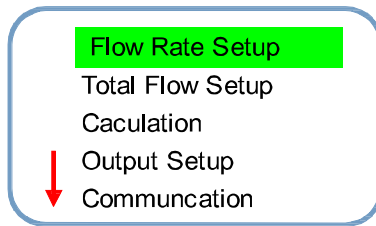

Figure 2

After the interface is shown in Figure 2, press or then you can choose different set items.

Press then return to the flow display interface (figure 1) :

Press or move the cursor to the sub menu, press go to sub menu to setup the parameter, for example, we need setup the "flowrate parameter", when this item become light, pree , then will display the menu as shown in figure 3 :

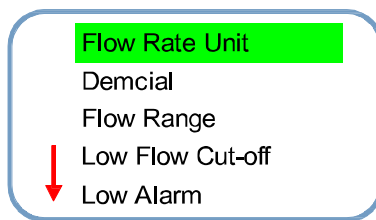

Figure 3

Press or to select the item which you want to modify, The selected item will brighten, if need return to the menu as shown in figure 2, then press ; If you need to enter the next level of items, then press to setup the parameters as shown in figure 4:

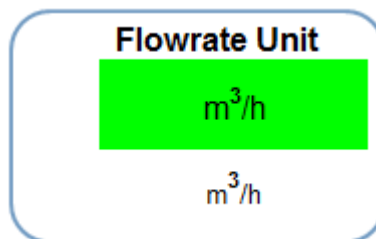

Figure 4

In this case, press or to modify the parameter, for example, as shown in figure 4, you need change the flowrate unit from " m³/h " to " m³/m ", then press , the flowrate unit will become to " m³/m ", as shown in figure 5:

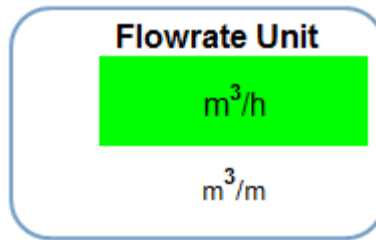



Figure 5

After you modify the parameter , if you need save, then press  , The system will prompt the "confirmation" and "exit" option, as shown in Figure 6:





图 6

In this case, press  , then save the setup and back (as shown in figure 3) ; if do not need save the parameter, then press  to back (as shown in figure 3) 。

3. Wiring Diagram And Output Define

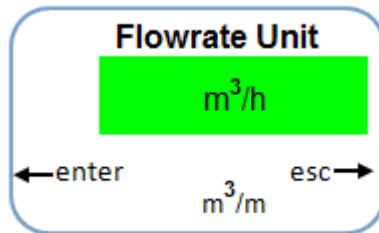
3.1 Integral Type Wiring Diagram (AC and DC Power Supply Type)

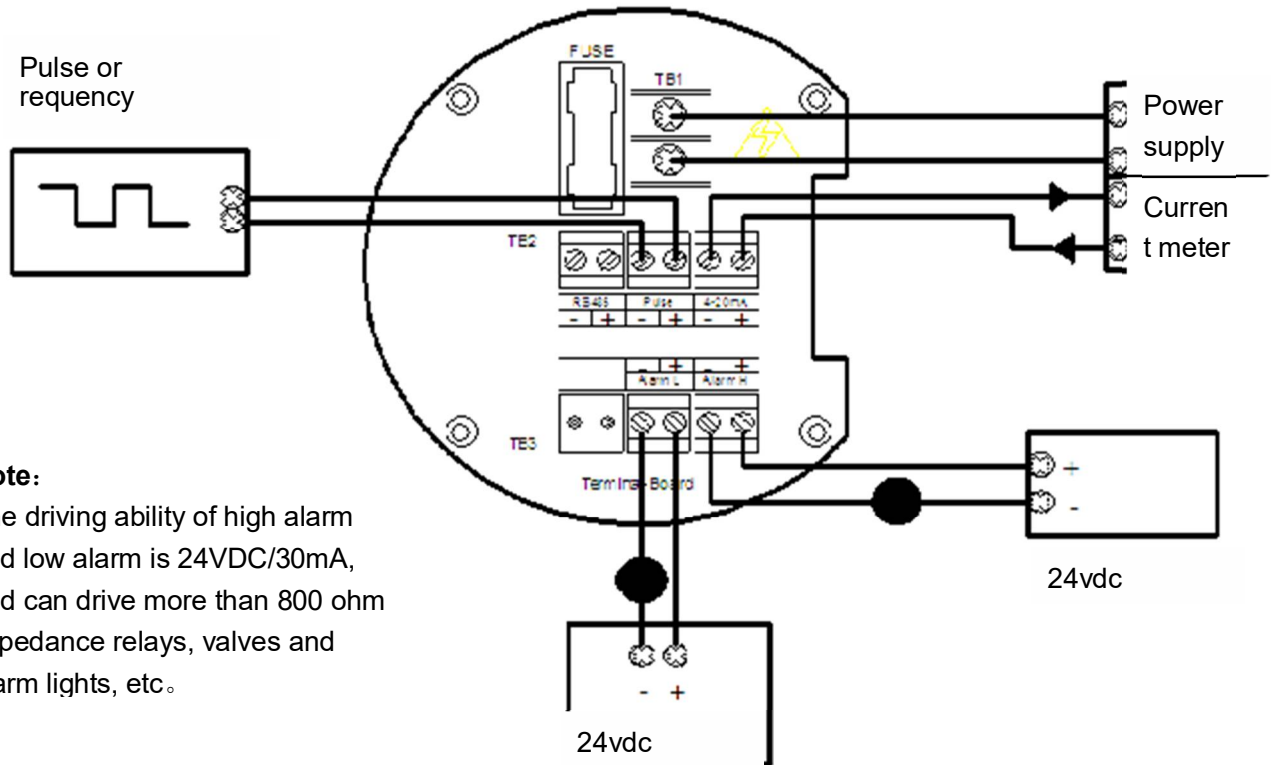

Note:

The driving ability of high alarm and low alarm is 24VDC/30mA, and can drive more than 800 ohm impedance relays, valves and alarm lights, etc.

The meaning of each terminal is as follows

Identification	Funcation	Remarks
L	AC 85 - 265V	L : AC220V power supply (fire line)
N	AC 85 - 265V	N : AC220V power supply (Zero line)
24V	DC 18 - 36V +	Power supply 24V+
COM	DC 18~36v -	Power supply 24V-
4-20mA	+ 4~20Ma +	The load resistance is less than or equal to 500.ohm
	- 4~20mA -	
Pulse	+ Frequency & pulse output +	
	- Frequency & pulse output -	
RS485	+ RS485 +	RS485 output
	- RS485 -	
Alarm H	+ High alarm output +	Suggest use 24VDC intermediate relay, Load current ≤ 30mA
	- High alarm output -	
Alarm L	+ Low alarm output +	
	- Low alarm output -	

3.2 Separate Type Wiring Diagram (AC and DC Power Supply Type)

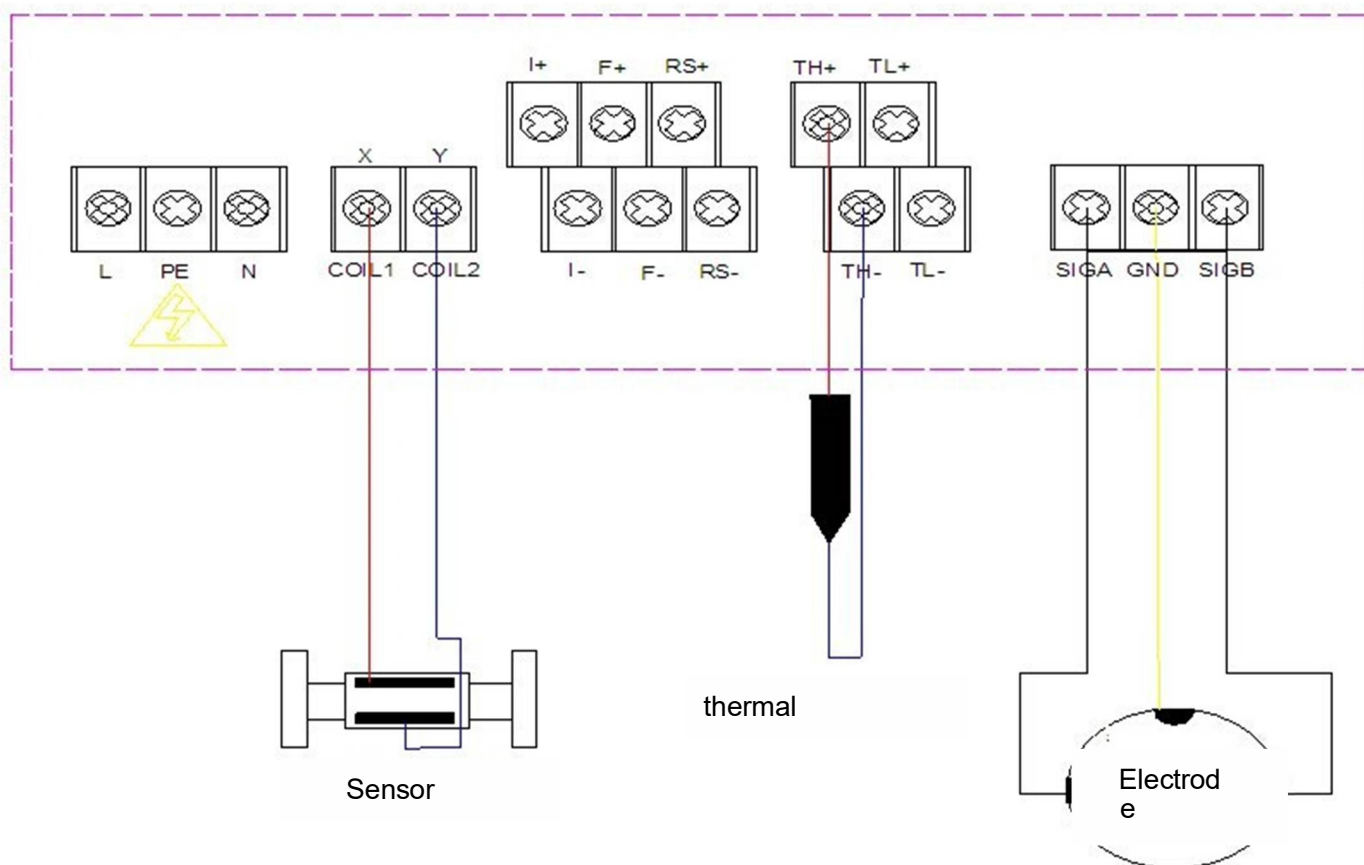

Identification	Funcation	Remarks
L	AC 85~265V	L: AC 86-220V fire line
PE		
N	AC 85~265V	N : AC 86-220V zero line
24V+	DC 16~36V +	24VDC+ power supply
24V-	DC 16~36V -	24VDC- power supply
lout1	4~20mA output1+	The load resistance is less than or equal to 500.ohm
lcom	4~20mA output1-	
lout2	4~20mA output2+	
lcom	4~20mA output2-	
POUT	Frequency&pulse output +	
PCOM	Frequency&pulse output -	
RS+	RS485 +	RS485 output terminal
RS-	RS485 -	
RTDA(24vdc)	Pt100 or Pt1000	Connect to inlet temperature sensor Connect to outlet temperature sensor
RTD-(24vdc)		
RTDB(24vdc)		
ALMH	High alarm output +	Suggest use 24VDC intermediate relay , Load current ≤ 30mA
ACOM	High alarm output -	
ALML	Low alarm output +	
ACOM	Low alarm output -	
TH +(220vac)	Pt100 or Pt1000	Connect to inlet temperature sensor
TH -(220vac)		
TL+(220vac)	Pt100 or Pt1000	Connect to outlet temperature sensor

TL -(220vac)		
coIL1	connecting to excitation coil of sensor.	
coIL2		
SIG1	electrode 1	Connect to signal electrode 1
GND	Signal ground	Connect to the grounding electrode
SIG2	electrode 2	Connect to Signal electrode 2

3.3 Battery Power Flow Transmitter wiring Diagram (3.6V lithium battery)

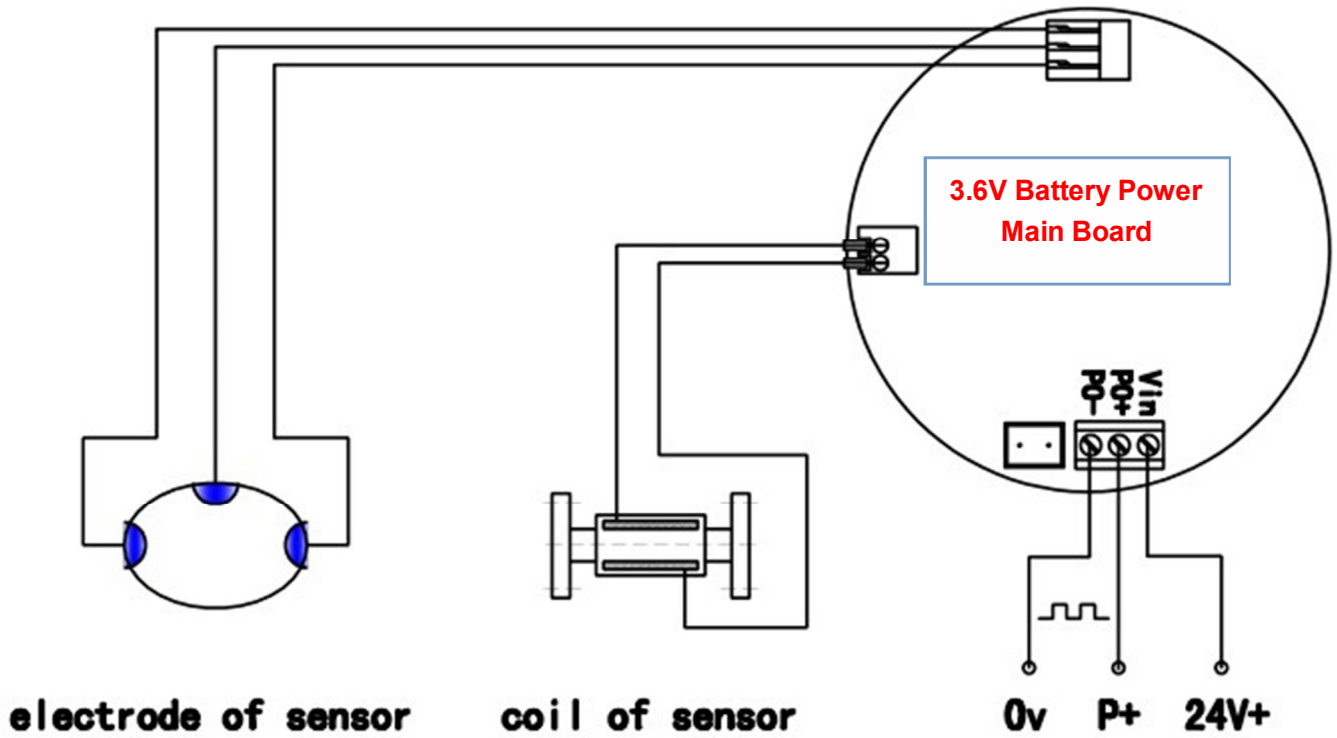

Note:

For **battery power emf transmitter** , pulse output is only used to calculate the flow meter normally , without pulse output . you need operate as flowing :

First keep the key  pressed ,, and second press  . then will display pulse output symbol and output pulse signal .

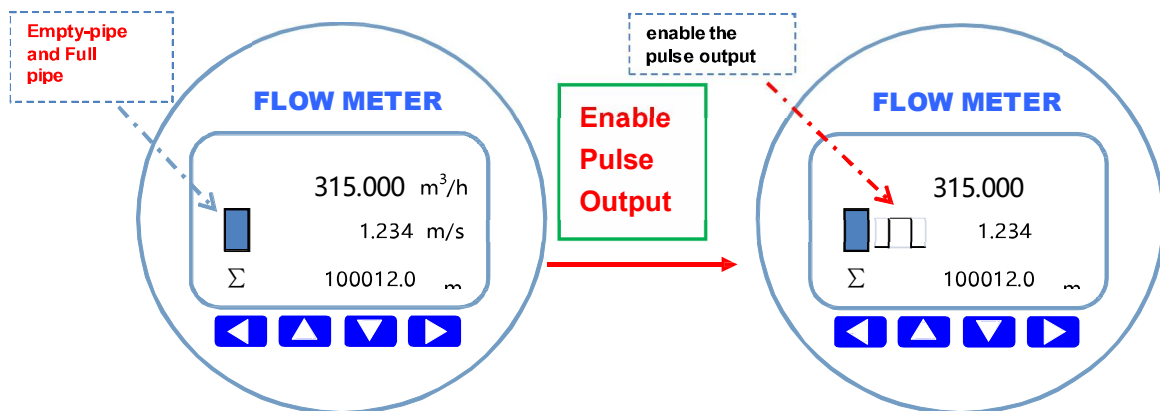

3.4 Connection Between Transmitter And Sensor

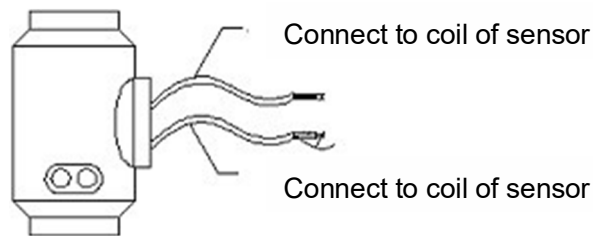

two core line (connect to the coil of sensor, three core wire with shield connection to the electrode of sensor .

3.5 Frequency Output Mode:

Frequency output range is 0 to 5000HZ, the frequency output corresponds to the percentage of flowrate.

$$F = \frac{\text{Flow Rate}}{\text{Flow Range}} \times \text{Upper Frequency Limit}$$

Frequency output mode is generally used to control the occasion, because it reflects the percentage of traffic, if the user is used for measurement occasions, it should choose the pulse output mode.

The frequency output is provided with an internal 24VDC power supply and NPN way.

If you need use the frequency output mode , then three parameters must setup:

- Setup “upper frequency limit”
- Setup “flow range” (corresponding to upper frequency limit)
- Setup “Pulse equivalent value” = 0

3.6 Pulse Equivalent Output Mode:

Pulse equivalent value: 0.001L, 0.01L, 0.1L, 1L, 0.001 M³ . The user should pay attention to the matching of the flow range and the pulse equivalent when selecting the pulse equivalent. If the flowrate is too large and the pulse equivalent selection is too small, it will cause the upper limit of the pulse output, so the pulse output frequency should be limited to the following 3000Hz. If the flowrate is small and the pulse equivalent is too large, it will cause the meter to output a pulse for a long time. In addition, it must be explained that the pulse output is different with the frequency output, the pulse output is a pulse equivalent to output a pulse, therefore, the pulse output is not very uniform. The general measurement of the pulse should use the counter meter, not choose the frequency meter.

The pulse output is provided with an internal 24VDC power supply and NPN way.

3.7 Analog Output Mode (4-20Ma)

The current output corresponds to the percentage of instantaneous flow. The current output is provided with an internal 24VDC power supply.

$$I_0 = \frac{\text{Flow Rate}}{\text{Flow Range}} \times 16 + 4.0$$

For 4 ~ 20mA signal system, the current zero is 4mA. Therefore, in order to improve the resolution of the output analog current, the flow range of the flowmeter should be selected properly.

3.6V battery power EMF type have no 4 to 20 Ma signal output .

4. Key Points of Attention

4.1 Installation

The flow meter is installed correctly on the pipe to ensure the straight pipe section and the installation position and the grounding to meet the requirements, as shown in the following figure:

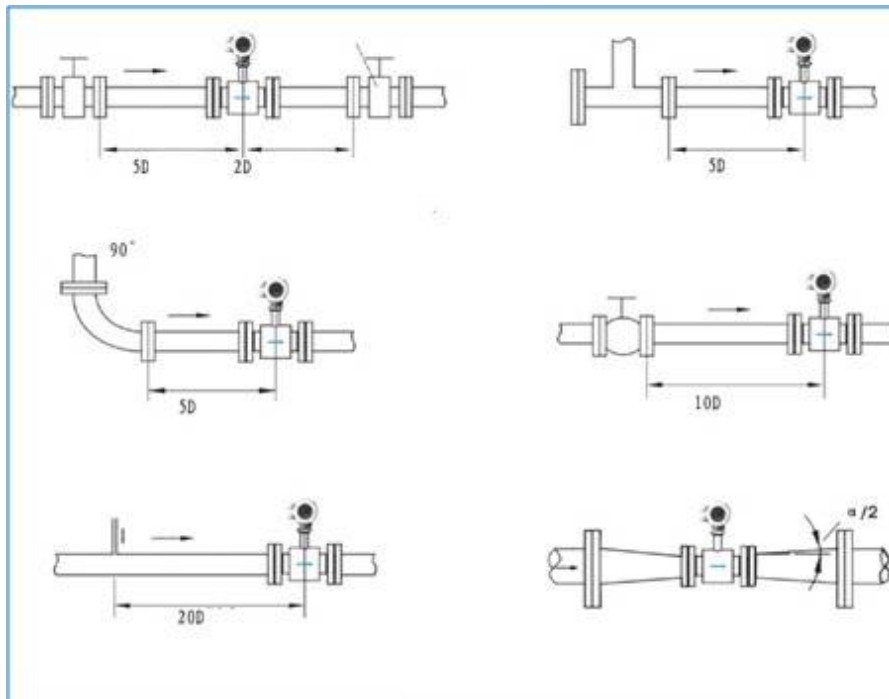
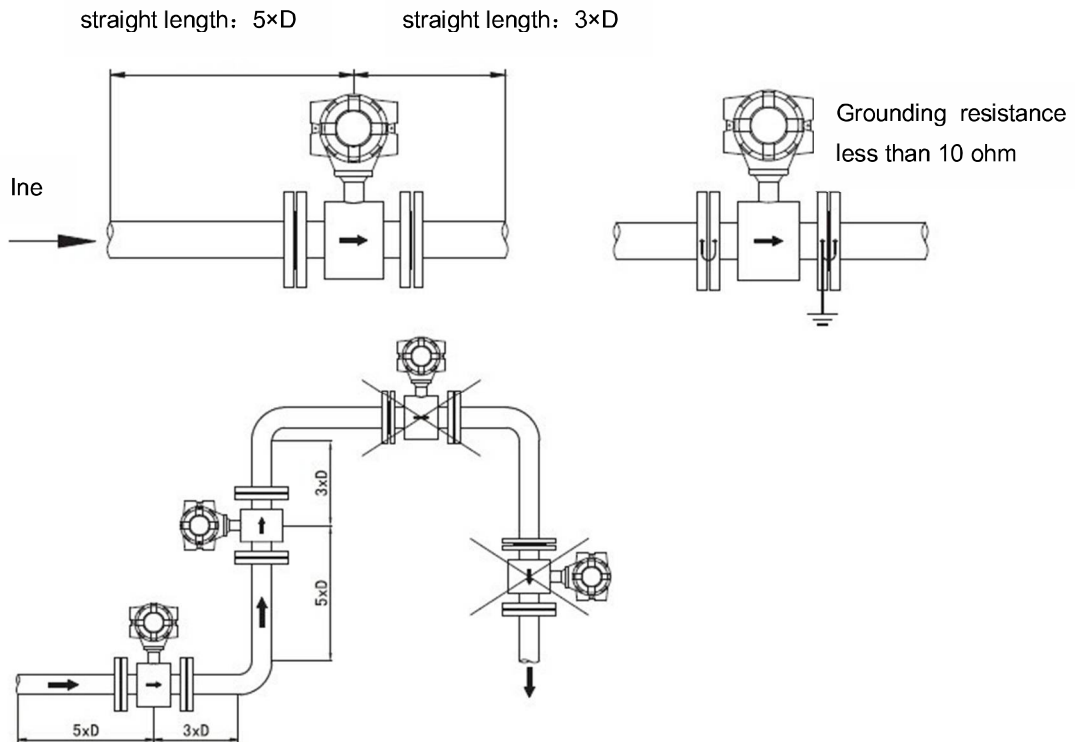

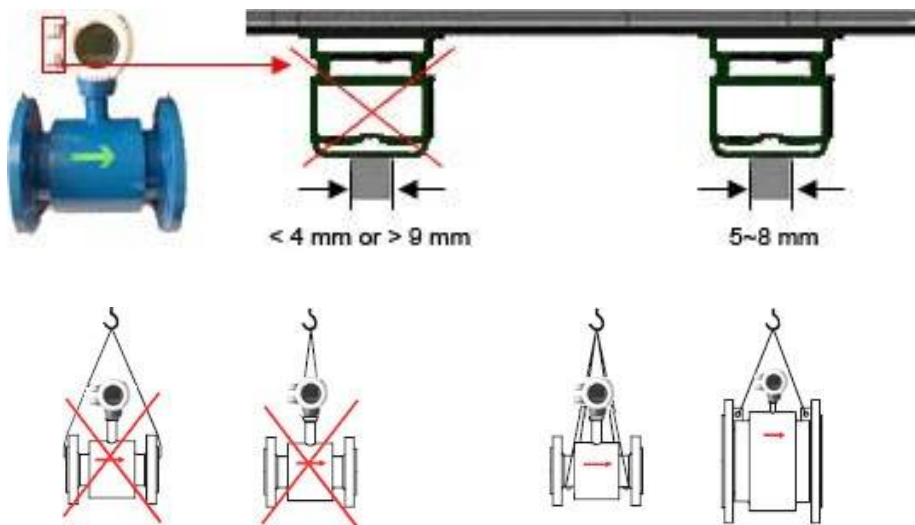
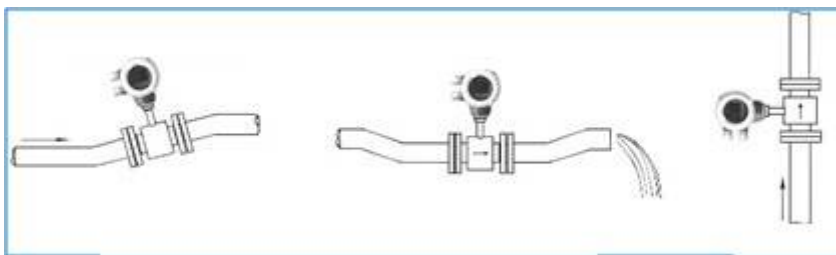
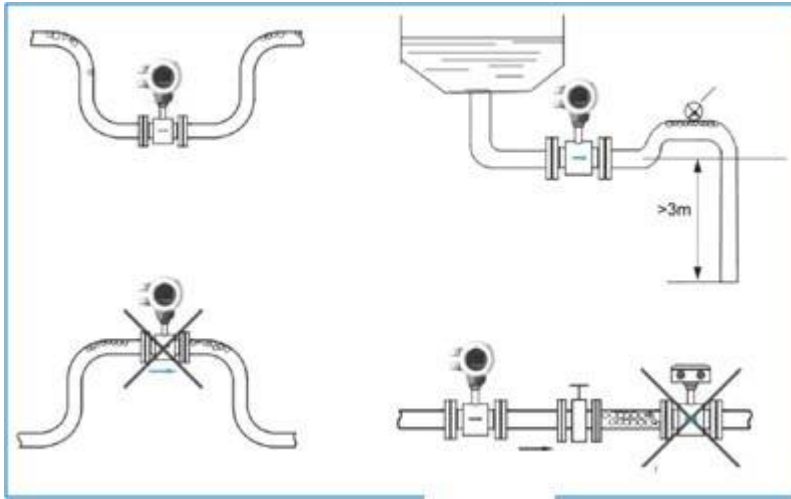

4.2 Power On And Preheat

The flow meter need to be warm up for at least 15 minutes after power on .

4.3 Set The Instrument Parameters Correctly

Go to <factory setup>, setup the Reduced excitation frequency and size and another parameters

Go to <flowrate parameter setup>, setup the flowrate and another parameters

If use frequency output ,then go to <output parameter setup>, set the “up frequency”

If use Pulse equivalent output , then go to <output parameter setup>, set the Pulse equivalent.

4.4 Calibrate The Zero of Flowmeter

The zero calibration of flowmeter is very important for Instrument accuracy. Make sure that the pipe is filled with

fluid and is in a static state and grounding , by using the automatic test function of the converter, the zero point of the instrument is obtained. Please note: the actual zero value must less 2mv , if the actual zero value is more than 2mv, maybe the accuracy will be affected.If the actual zero value is more than 2 mv, you must check the following item:

- the sensor maybe not ok;
- the grounding resistance maybe is not meet the requirement.
- Reduced excitation frequency and calculate the zero again .

4.5 Relationship Between Battery Life And Sensor Size

Battery Type	Battery Life		
	Size ≤DN150	DN200≤Size ≤DN350	DN400≤Size ≤DN600
Internal Battery	33 months	30 months	26 months
External Battery	72 months	72 months	72 months

If your sensor size is big ,and need long battery life , then need install external battery..and different size , the external battery capacity is different. If the size is greater than DN600, then the internal battery life is short than 26 months , so suggest use external battery .if you need install external battery , then ask usd , we can provide the battery parameters and Installation method.

5.Packing and Storage

MYA seial flow meter transmitter is packed in a special foam box to prevent damage during transportation,Random files include: operation manual, certificate, packing list, etc. In order to prevent the instrument from being damaged during transport, please keep the packing status of the manufacturing plant before it arrives at the installation site。 Storage sites should possess the following conditions: placed in the interior and rainproof and moisture-proof and small mechanical vibration。

6.Appendix

Appendix 1: Flow Meter Transmitter Mode

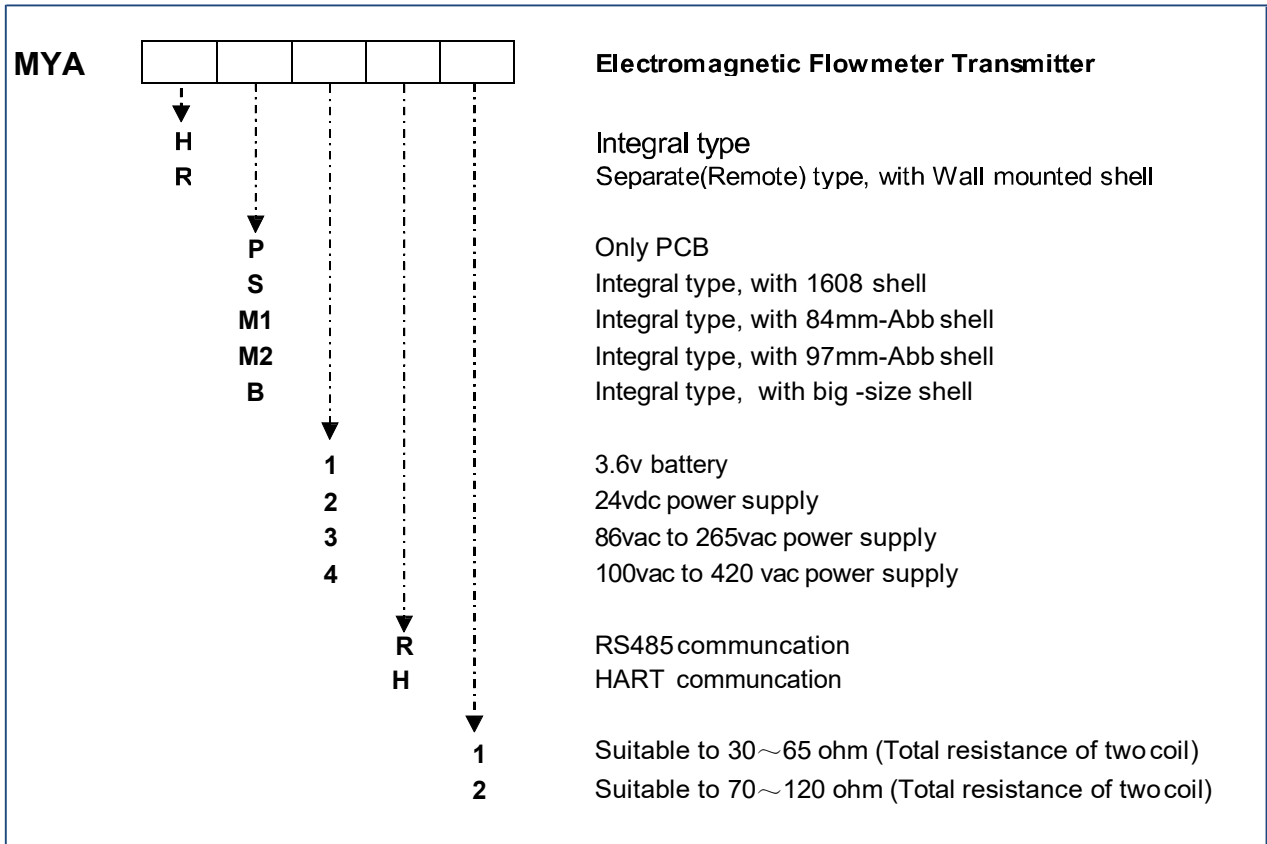

Appendix 2: Electromagnetic Flow Meter Mode (MYA)

MYA		Electromagnetic Flowmeter Transmitter
	▼	
	H R	
	▼	
	S	Integral type
	M1	Separate (Remote) type, with Wall mounted shell
	M2	Integral type, with 1608 shell
	B	Integral type, with 84mm-Abb shell
	▼	Integral type, with 97mm-Abb shell
	1	Integral type, with big -size shell
	2	3.6v battery
	3	24vdc power supply
	4	86vac to 265vac power supply
	▼	100vac to 420 vac power supply
	R	RS485 communcation
	H	HART communcation
	▼	PTFE Lining
	P	Rubber Lining
	R	FEP Lining
	F	SS316L electrode
	▼	Hastelloy B electrode
	0	Hastelloy C electrode
	1	Titanium electrode
	2	Tantalum electrode
	3	Platinum electrode
	4	PN1.0 mPa
	5	PN16 mPa
	▼	PN25 mPa
	0	PN40 mPa
	1	PN63 mPa
	2	JIS 10K
	3	JIS 20K
	4	ANSI Class 150
	5	ANSI Class 300
	6	ANSI Class 600
	7	IP65
	8	IP68
	9	Accuracy 0.25%
	▼	Accuracy 0.5%
	0	
	1	
	▼	
	A	
	B	

Appendix 3: Outline Dimension (Insert Electromagnetic Flowmeter)

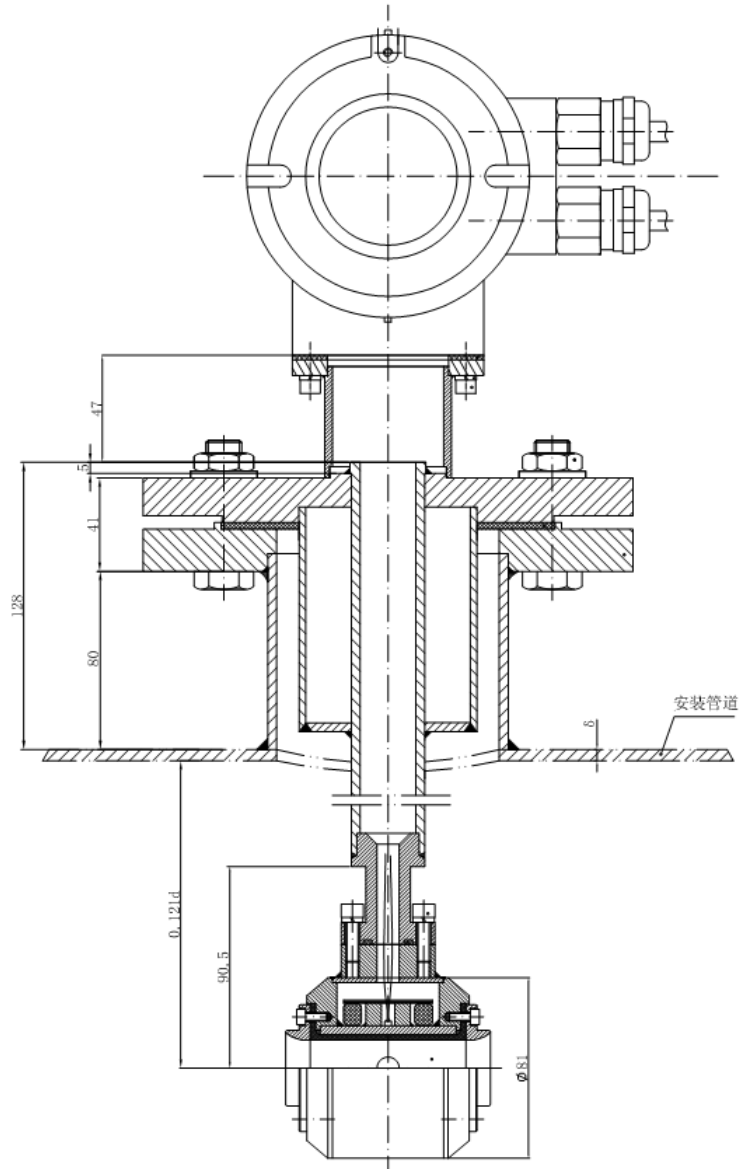

Appendix 4: Outline Dimension (Flange Type Electromagnetic Flowmeter)

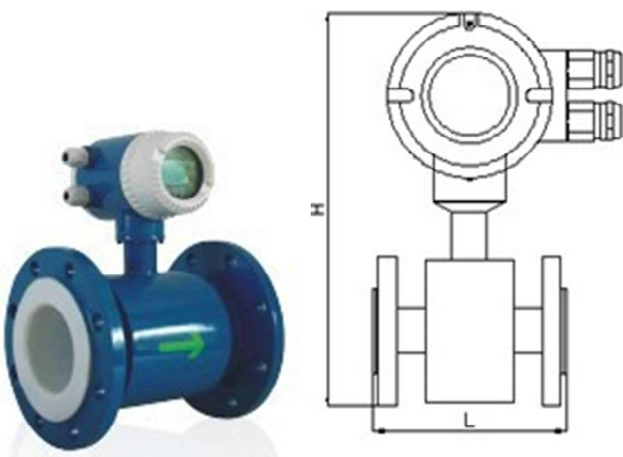

SIZE	L mm	SIZE	L mm
DN10	160	DN250	400
DN15	160	DN300	500
DN20	160	DN350	500
DN25	160	DN400	600
DN32	160	DN450	600
DN40	200	DN500	600
DN50	200	DN600	600
DN65	200	DN700	700
DN80	200	DN800	800
DN100	250	DN900	900
DN125	250	DN1000	1000
DN150	300	DN1200	1200
DN200	350	DN1400	1400

Appendix "RS485 Communication Address Table"

Appendix 5: Instrument variable address definition

The following is a list of data variables that are supported by the instrument, the data are HEXtype

Variable name	Register start address	Register length	Read instruction	write command
Coil Type				
Clear total flow	145	***	***	05
Int Type				
Flow rate unit	0	0001	03	06
Flow rate decimal	8	0001	03	06
Total unit	16	0001	03	06
Total flow decimal	24	0001	03	06
Pulse level	80	0001	03	06
Device No	120	0001	03	06
Modbus mode	88	0001	03	***
baud rate	96	0001	03	***
Date bit	104	0001	03	***
Check mode	112	0001	03	***
Long type				
Total flow extend	1280	0002	03	***
Total flow	1282	0002	03	***
Float Type				
Damping time	32	0002	03	10
Low cut-off	48	0002	03	10
Upper frequency limit	56	0002	03	10
Pulse equivalent	64	0002	03	10
pulse width	72	0002	03	10
Low alarm	192	0002	03	10
High alarm	208	0002	03	10
density	152	0002	03	10
Flow rate	1800	0002	03	***
Total flow	1284	0002	03	***
Double Type				
Flow range	40	0004	03	10
Sensor k-factor	136	0004	03	10
Total flow	144	0004	03	***
Flow rate	1792	0004	03	***

Note:

- The start address data is 16 binary , if need 10 binary , then need convert.
- The data bit is 32 bit.
- If connect to PLC ,maybe the start address will add "1" , for example , if the start address is 0708 , then will becom 0709 (for PLC)

Appendix 6: Fault Code

0x01	Invalid instruction code
0x02	Invalid register address
0x30	Parameter over limit
0x31	Super lower limit of parameters
0x32	Parameter selection error
0x40	Invalid register length
0x41	The register does not support the current instruction code
0x42	Register not specified
0x43	Instantaneous flow unit does not exist
0x44	Total unit does not exist
0x45	Maximum frequency output over limit
0x46	Minimum frequency output
0x47	Maximum flow rate over the upper limit
0x48	Duty cycle over limit
0xFE	Data frame confusion
0xFF	Data frame check error

Appendix 7: Definition of Common Units

Flow rate	m ³ /h	0
	m ³ /m	1
	m ³ /s	2
	L/h	3
	L/m	4
	L/s	5
	USG/h	6
	USG/m	7
	USG/s	8
	kg/h	9
	kg/m	10
	kg/s	11
	t/h	12
	t/m	13
t/s	14	
Total flow	L	0
	m ³	1
	USG	2
	kg	3
	t	4

Appendix 8: Symbolic Code Definition

Modbus mode	RTU	0
	ASCII	1
Check mode	Even check	0
	Parity check	1
	No parity	2
Baud rate	1200bps	0
	2400bps	1
	4800bps	2
	9600bps	3
	19200bps	4
	38400bps	5
Data bit	7 bit	0
	8 bit	1
Decimal	小数点后0位	0
	小数点后1位	1
	小数点后2位	2
	小数点后3位	3

Appendix 9: Size Code Definition

Size	Code	Size	Code
DN1	0	DN600	27
DN1.5	1	DN700	28
DN2	2	DN750	29
DN3	3	DN800	30
DN4	4	DN900	31
DN5	5	DN1000	32
DN6	6	DN1100	33
DN8	7	DN1200	34
DN10	8	DN1300	35
DN15	9	DN1350	36
DN20	10	DN1400	37
DN25	11	DN1500	38
DN32	12	DN1600	39
DN40	13	DN1700	40
DN50	14	DN1800	41
DN65	15	DN2000	42
DN80	16	DN2100	43

DN100	17	DN2200	44
DN125	18	DN2300	45
DN150	19	DN2400	46
DN200	20	DN2500	47
DN250	21	DN2600	48
DN300	22	DN2700	49
DN350	23	DN2800	50
DN400	24	DN2900	51
DN450	25	DN3000	52
DN500	26		