

**80 G**

**FM Radar Level Meter**

Product Manual

---

# Directory

1、 Product Overview.....	1
2、 Product Introduction.....	3
3、 The Installation Requirements.....	6
4、 The Electrical Connection.....	12
5、 Structure Size.....	15
6、 Technical Parameters.....	18
7、 Meter Linearity.....	19
8、 Product Model Selection.....	21

# 80G FM Radar Level Meter

## Principle:

The general principle of the FM continuous wave radar level gauge is that the radar emits electromagnetic waves on the top of the tank, and the electromagnetic waves are received by the radar after being reflected by the medium. The frequency difference  $\delta f$  between the received signal and the transmitted signal is proportional to the distance  $R$  from the surface of the medium:  $R = C \cdot (\text{speed}) \cdot \delta f \text{ (frequency difference)} / 2 / K \text{ (frequency modulation slope)}$ . Because the speed of light  $C$  and the frequency modulation slope  $K$  are known, the frequency difference  $\delta f$  can be estimated to obtain the distance  $R$  from the radar installation position to the material surface, and then through the known total height of the tank, subtract the spatial distance from the radar to the material surface (referred to as Empty height) to get the height of the material level.

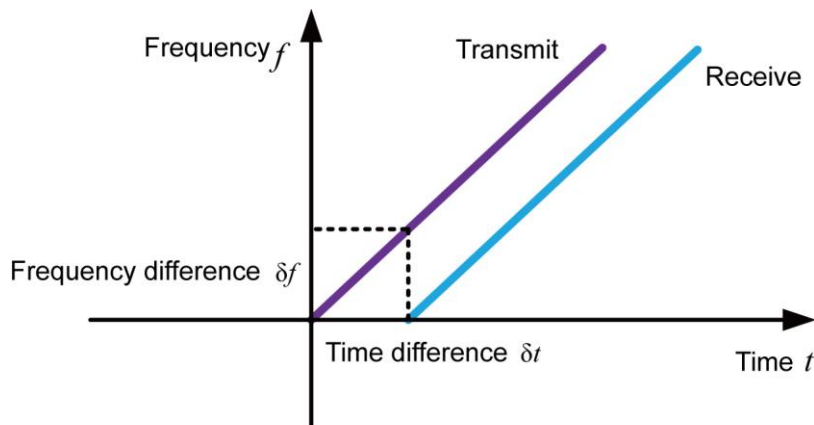

$$\left. \begin{array}{l} \text{Time difference } \delta t = 2R/C \\ \text{Frequency difference } \delta f = K \cdot \delta t \end{array} \right\} \Rightarrow \text{Distance } R = C \cdot \delta f / 2 / K$$

Note:  $K$  is the frequency modulation slope

## Characteristic:

1. Millimeter-wave radar, with a measurement accuracy of up to  $\pm 1\text{mm}$ , and a minimum blind area of  $0.1\text{m}$ .
2. The smaller antenna size satisfies the measurement of more working conditions.
3. A variety of lens antennas, smaller launch angle, more concentrated energy, stronger echo signal, under the same industrial and mining conditions, compared to Other radar products have higher reliability.
4. With stronger penetrability, it can be used normally even if there is adhesion and condensation.
5. The dynamic signal range is larger, and the measurement of low dielectric constant medium is more stable.
6. A variety of measurement modes, the radar reaction time in the fast measurement mode is less than  $1\text{S}$ .

## ● Product Introduction

### ● FMW11S



Measuring medium: Liquid  
Measuring range: 0.1m~10m  
Process connection: Thread G $\frac{3}{4}$ "A /  $\frac{3}{4}$ "NPT  
Flange  $\geq$ DN25

Process temperature: -40~100°C  
Process pressure: -0.1~1.6 MPa  
Antenna size:21mm lens antenna  
Antenna material: PTFE  
Accuracy:  $\pm$ 5mm  
Protection level: IP67  
Center frequency: 80GHz  
Launch angle:14°  
Power source: Two-wire system/DC24V  
Four-wire system/AC220V  
Six-wire system/DC12-24V

Shell: Aluminum/Plastic/Stainless steel  
Signal output: Two-wire system/4...20mA/HART protocol  
Four-wire system/4...20mA/HART protocol  
Six-wire system/4...20mA/HART protocol

### ● FMW11



Measuring medium: Liquid  
Measuring range: 0.1m~30m  
Process connection: Thread G $\frac{1}{2}$ "A / 1  $\frac{1}{2}$ "NPT  
Flange  $\geq$ DN40

Process temperature: -40~80°C  
Process pressure: -0.1~0.3 MPa  
Antenna size:32mm lens antenna  
Antenna material: PTFE  
Accuracy:  $\pm$ 2mm  
Protection level: IP67  
Center frequency: 80GHz  
Launch angle: 8°  
Power source: Two-wire system/DC24V  
Four-wire system/AC220V  
Six-wire system/DC12-24V

Shell: Aluminum/Plastic/Stainless steel  
Signal output: Two-wire system/4...20mA/HART protocol  
Four-wire system/4...20mA/HART protocol  
Six-wire system/4...20mA/HART protocol

- **FMW12**



Measuring medium: Liquid  
Measuring range: 0.1m~30m  
Process connection: Flange  $\geq$  DN40  
Process temperature: -40~100°C  
Process pressure: -0.1~0.3 MPa  
Antenna size: 32mm lens antenna  
Antenna material: PTFE  
Accuracy:  $\pm$ 2mm  
Protection level: IP67  
Center frequency: 80GHz  
Launch angle: 8°  
Power source: Two-wire system/DC24V  
Four-wire system/AC220V  
Six-wire system/DC12-24V  
Shell: Aluminum/Plastic/Stainless steel  
Signal output: Two-wire system/4...20mA/HART protocol  
Four-wire system/4...20mA/HART protocol  
Six-wire system/4...20mA/HART Protocol

---

- **FMW13**



Measuring medium: Liquid  
Measuring range: 0.2m~30m/0.3~150m  
Process connection: Flange  $\geq$  DN80  
Process temperature: -40~120°C  
Process pressure: -0.1~1.0 MPa  
Antenna size: 76mm lens antenna  
Antenna material: PTFE  
Accuracy:  $\pm$ 2mm  
Protection level: IP67  
Center frequency: 80GHz  
Launch angle: 3°  
Power source: Two-wire system/DC24V  
Four-wire system/AC220V  
Six-wire system/DC12-24V  
Shell: Aluminum/Plastic/Stainless steel  
Signal output: Two-wire system/4...20mA/HART protocol  
Four-wire system/4...20mA/HART protocol  
Six-wire system/4...20mA/HART Protocol

## ● FMW14



Measuring medium: Liquid  
Measuring range: 0.1m~30m  
Process connection: Flange  $\geq$  DN50  
Process temperature: -40~200°C  
Process pressure: -0.1~2.5 MPa  
Antenna size: 44mm lens antenna  
Antenna material: PTFE  
Accuracy:  $\pm$ 2mm  
Protection level: IP67  
Center frequency: 80GHz  
Launch angle: 6°  
Power source: Two-wire system/DC24V  
Four-wire system/AC220V  
Six-wire system/DC12-24V  
Shell: Aluminum/Plastic/Stainless steel  
Signal output: Two-wire system/4...20mA/HART protocol  
Four-wire system/4...20mA/HART protocol  
Six-wire system/4...20mA/HART protocol

## ● FMW15



Measuring medium: Liquid  
Measuring range: 0.3m~30m  
Process connection: Flange  $\geq$  DN80  
Process temperature: -40~200°C  
Process pressure: -0.1~2.5 MPa  
Antenna size: 76mm lens antenna  
Antenna material: PTFE  
Accuracy:  $\pm$ 2mm  
Protection level: IP67  
Center frequency: 80GHz  
Launch angle: 3°  
Power source: Two-wire system/DC24V  
Four-wire system/AC220V  
Six-wire system/DC12-24V  
Shell: Aluminum/Plastic/Stainless steel  
Signal output: Two-wire system/4...20mA/HART protocol  
Four-wire system/4...20mA/HART protocol  
Six-wire system/4...20mA/HART Protocol

- **FMW21**



Measuring medium: Solid  
Measuring range: 0.1m~30m/0.3~150m  
Process connection: Flange  $\geq$  DN80  
Process temperature: -40~80°C/-40~120°C  
Process pressure: -0.1~0.3 MPa  
Antenna size: 76mm lens antenna  
Antenna material: PTFE  
Accuracy:  $\pm$ 5mm  
Protection level: IP67  
Center frequency: 80GHz  
Launch angle: 3°  
Power source: Two-wire system/DC24V  
Four-wire system/AC220V  
Six-wire system/DC12-24V  
Shell: Aluminum/Plastic/Stainless steel  
Signal output: Two-wire system/4...20mA/HART protocol  
Four-wire system/4...20mA/HART protocol  
Six-wire system/4...20mA/HART protocol

## FMW Installation requirements:

- **Installation method**

- 1. Threaded installation (applicable to FMW11s, HBRD-FMW11)

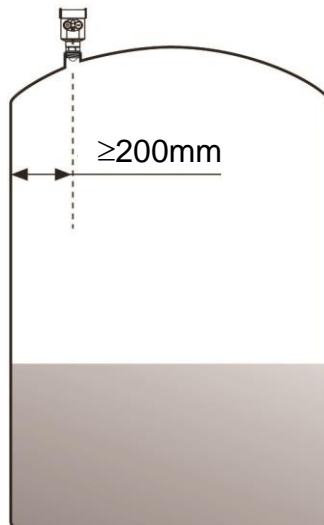

➤ 2. Flange installation

When using flange mounting, the minimum distance between the meter and the tank wall should be 200mm.

Note: ①Datum

②Container center or axis of symmetry

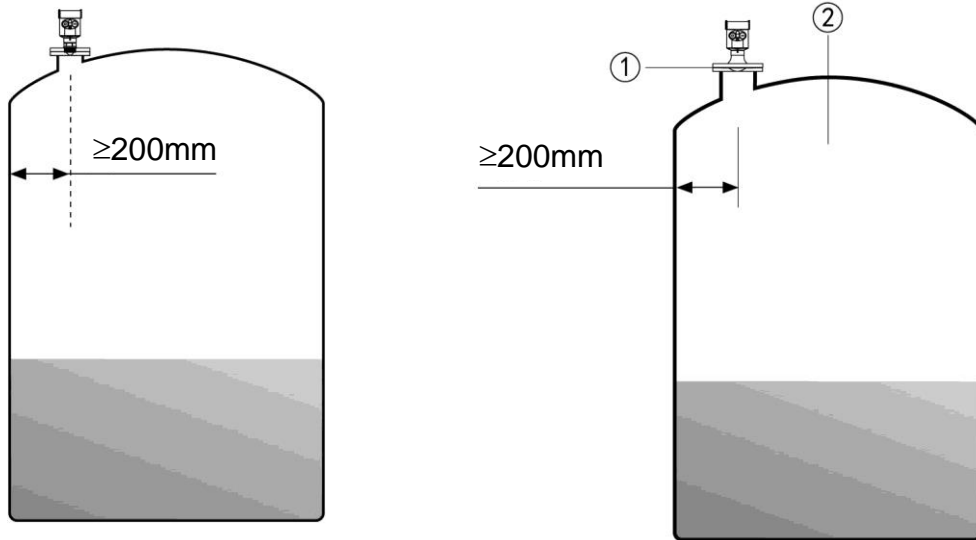

➤ 3. Lifting (selected according to specific installation conditions)

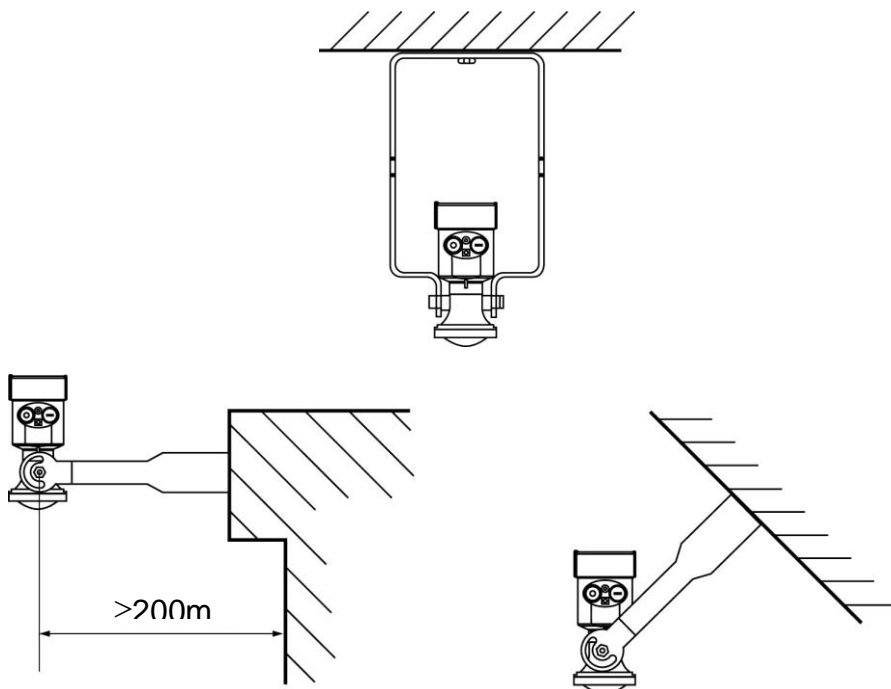

- **Installation requirements:**

When installing the instrument, avoid installing it above the material inlet, and try to avoid various objects that affect the signal, such as stirring paddles, etc.

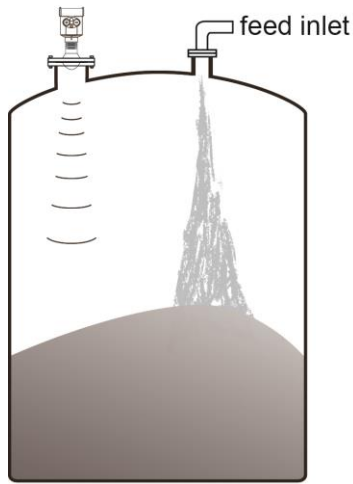

Solid measurement

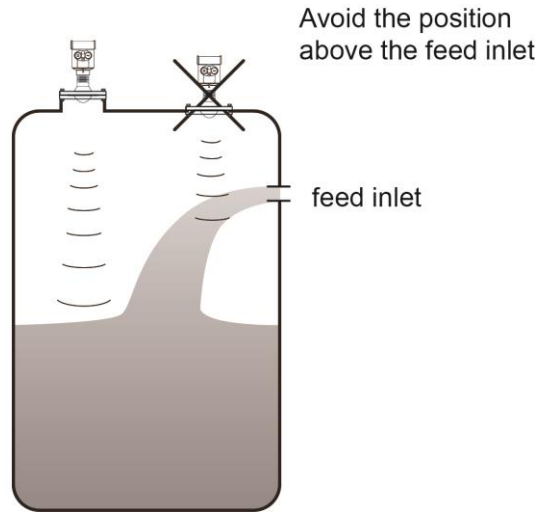

Measuring liquid

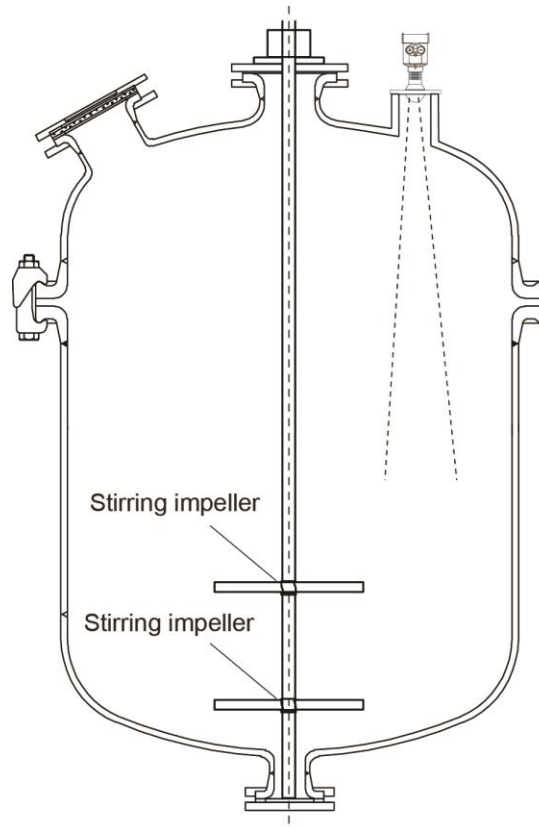

Remarks: Cannot be installed above the inlet, there can be no obstacles under the meter

Under extremely complex working conditions, the instrument can work normally with the radar installation point as the center and no obstacles in the area with a radius of 20 cm.

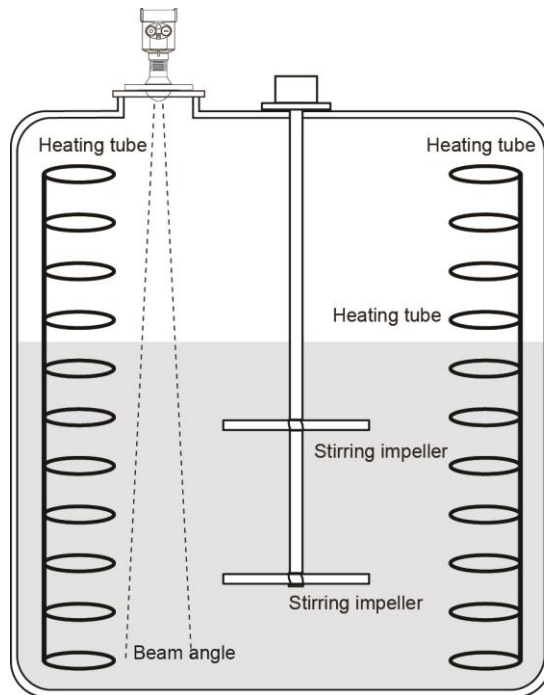

Extremely low emission angles ensure accurate measurements under extreme conditions

❖ Schematic diagram of installation and takeover

The maximum installation stub height  $H_{max}$  depends on the installation stub diameter  $D$  and the product launch angle. Long installation and takeover will affect radar performance.

➤ **FMW11s**

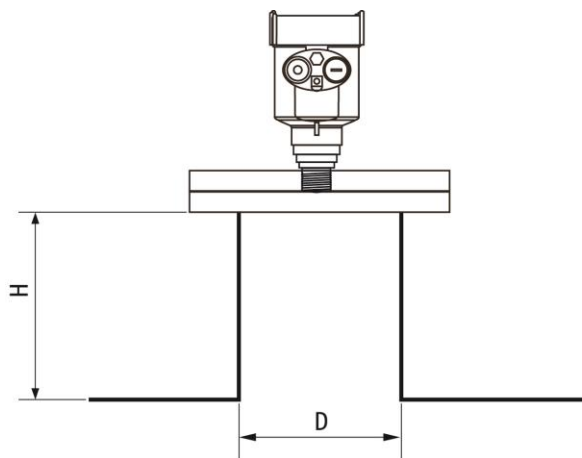

Flange	D	H max
DN25	25mm (2" )	90mm
DN40	40mm (2.5" )	140mm
DN50	50mm (3" )	180mm
DN65	65mm (4" )	240mm

➤ **FMW11**

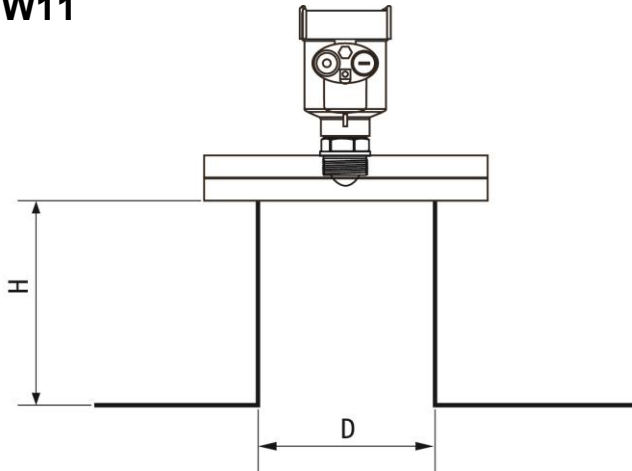

Flange	D	H max
DN40	40mm (1.5" )	250mm
DN50	50mm (2" )	300mm
DN65	65mm (2.5" )	450mm
DN80	80mm (3" )	550mm
DN100	100mm(4" )	700mm
DN125	125mm(5" )	900mm
DN150	150mm(6" )	1100mm

➤ **FMW12**

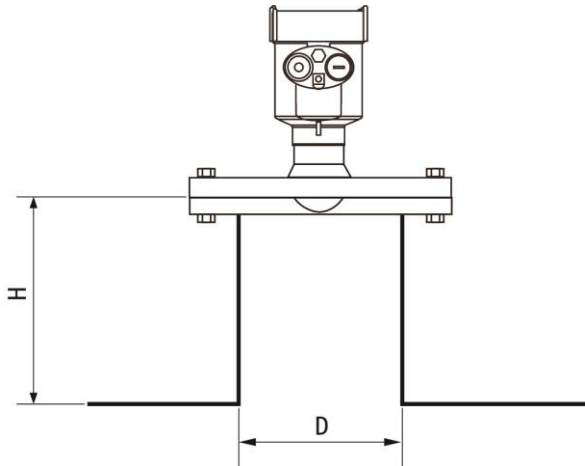

Flange	D	H max
DN40	40mm (1.5" )	250mm
DN50	50mm (2" )	300mm
DN65	65mm (2.5" )	450mm
DN80	80mm (3" )	550mm
DN100	100mm(4" )	700mm
DN125	125mm(5" )	900mm
DN150	150mm(6" )	1100mm

➤ **FMW13**

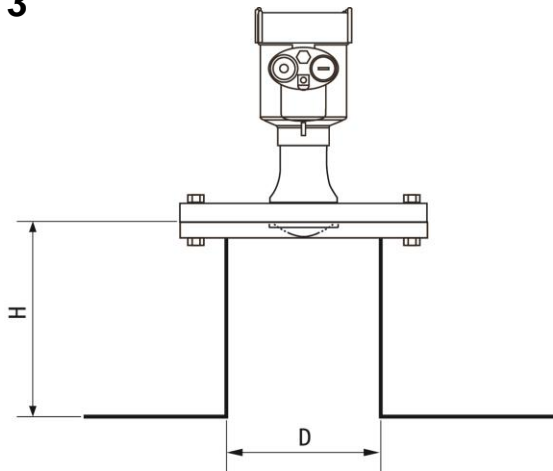

Flange	D	H max
DN80	80mm (3" )	1000mm
DN100	100mm (4" )	1200mm
DN125	125mm (5" )	1500mm
DN150	150mm (6" )	2000mm

➤ **FMW14**

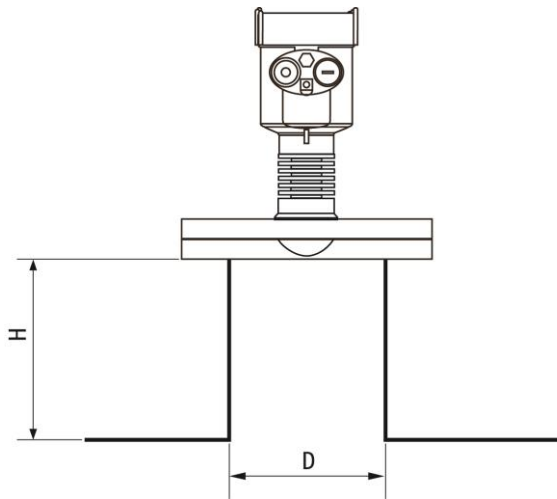

Flange	D	H max
DN50	50mm (2" )	400mm
DN80	80mm (3" )	650mm
DN100	100mm (4" )	900mm
DN125	125mm (5" )	1000mm
DN150	150mm (6" )	1200mm

➤ **FMW15**

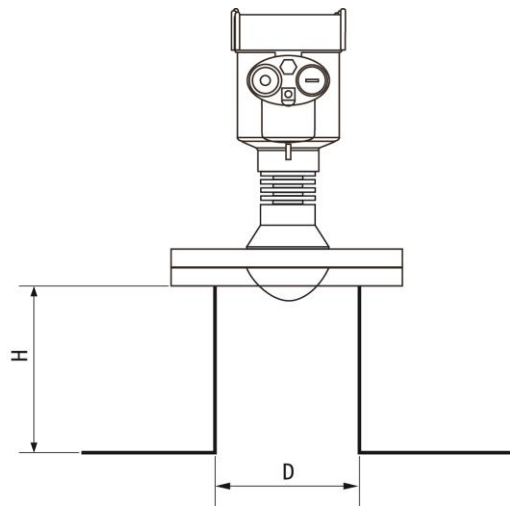

Flange	D	H max
DN80	80mm (3" )	1200mm
DN100	100mm (4" )	1500mm
DN125	125mm (5" )	2000mm
DN150	150mm (6" )	2500mm

➤ **FMW21**

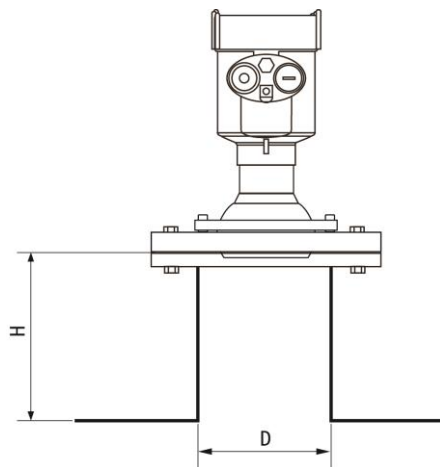

Flange	D	H max
DN80	80mm (3" )	1000mm
DN100	100mm (4" )	1200mm
DN125	125mm (5" )	1500mm
DN150	150mm (6" )	2000mm

# Electrical Connections

## ● Power Supply

(4~20) mA (2-wire)

The power supply and the output current signal share a two-core shielded cable. See technical data for specific power supply voltage range.

(4~20) mA (4/6-wire)

The power supply needs to be supplied separately, and the power supply and the current signal use a four-core shielded cable (the current signal and the RS485 interface can be output at the same time, and the output needs to use a six-core shielded cable).

Modbus-RS485

The power supply needs to be supplied separately, and the power supply and the digital use a four-core shielded cable (the current signal and the RS485 interface can be output at the same time, and the output needs to use a six-core shielded cable).

## ● Connection method

➤ 24V two-wire system wiring diagram is as follows:

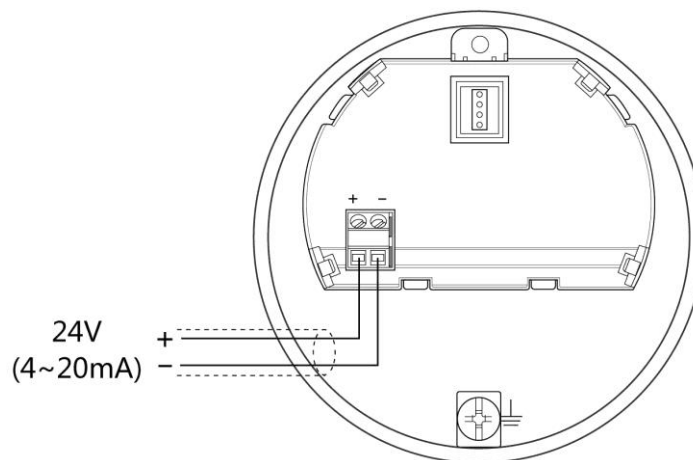

➤ Two-wire and two-chamber wiring diagram shown on the side is as follows:

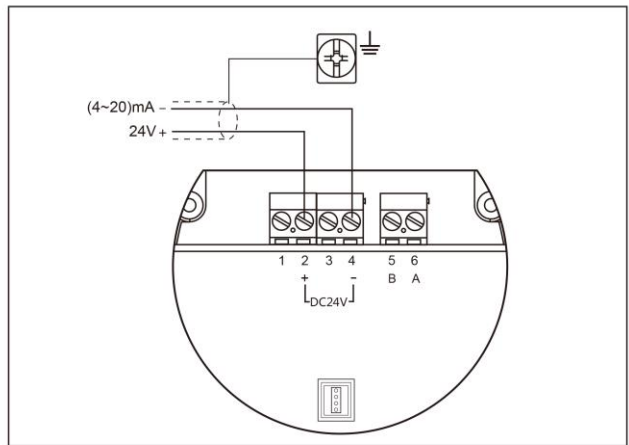

24V DC Power Supply  
4~20mA Output

➤ Four-wire, two-room wiring diagram:

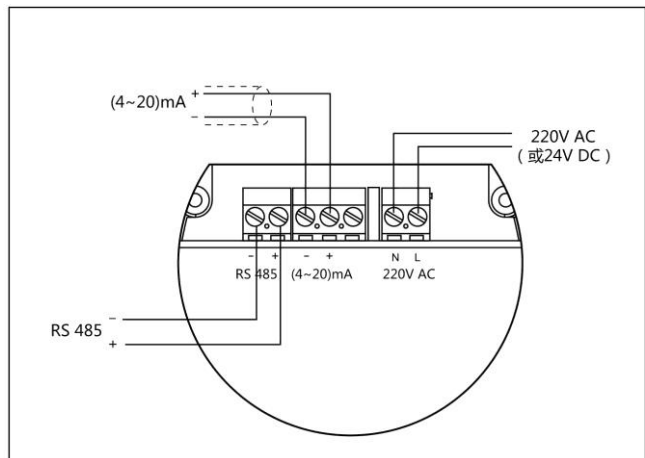

12-24V DC Power Supply  
( or 220V AC Power Supply ) ,  
RS485 /Modbus Output

six-wire wiring diagram of the four-wire system is as follows:

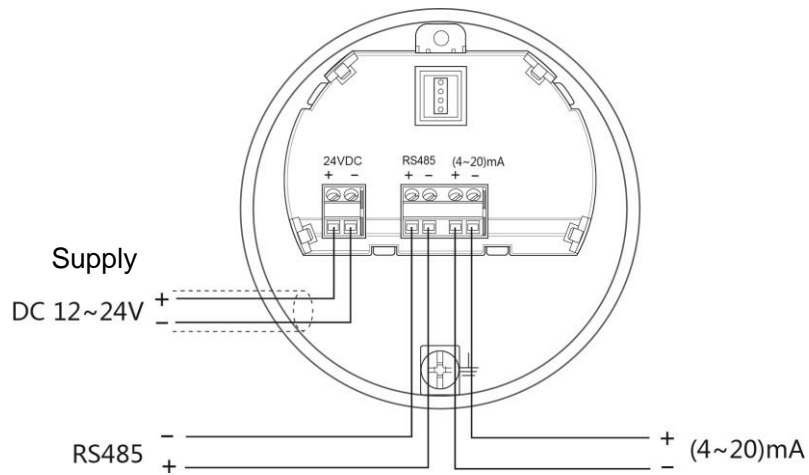

## ● Safety guidance

Please observe the requirements of the local electrical installation regulations!

Please observe local regulations regarding the health and safety of personnel. All operations on the electrical components of the instrument must be performed by trained professionals.

Please check the nameplate of the instrument to ensure that the product specifications meet your requirements. Make sure that the supply voltage is the same as that on the instrument nameplate.

## ● Protection level

This instrument fully meets the requirements of protection grade IP66/67. Please ensure the waterproof performance of the cable gland. As shown below:

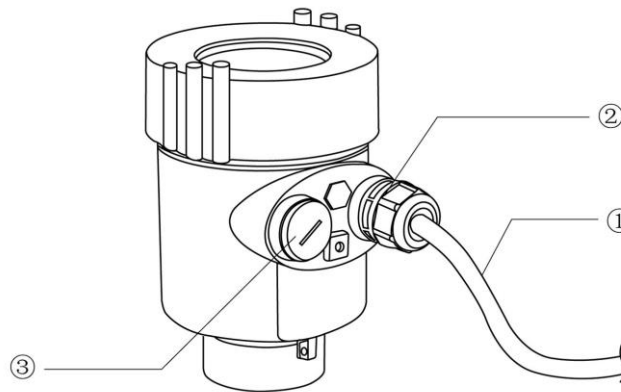

How to ensure that the installation meets the requirements of IP67:

Make sure the seal head is not damaged.

Make sure the cable is not damaged.

Make sure that the cable you are using meets the electrical connection specifications.

Before entering the electrical interface, bend the cable down to ensure that water does not flow into the housing, see ①

Please tighten the cable gland, see ②

Please block the unused electrical interface with a blind plug, see ③

# Structure Size:

- **The outer casing size (unit: mm)**

- Aluminum case:

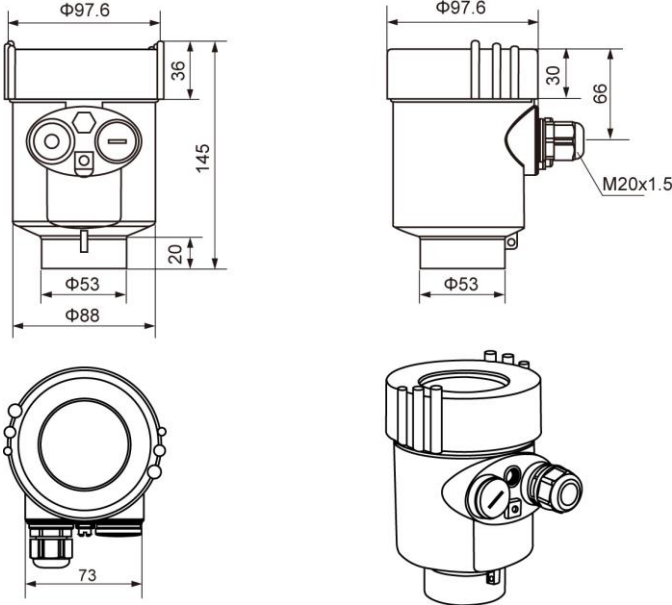

- Stainless steel case:

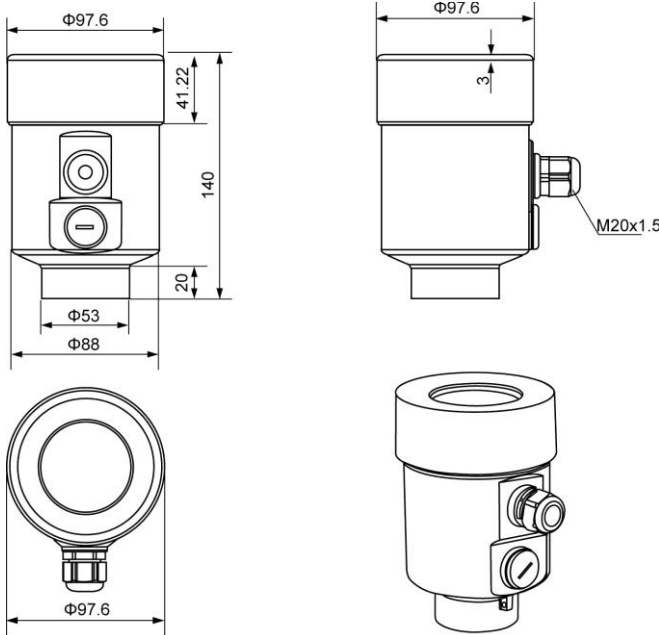

● **Product Size** (unit: mm)

➤ **FMW11s**

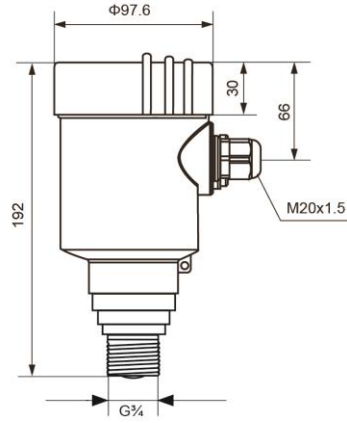
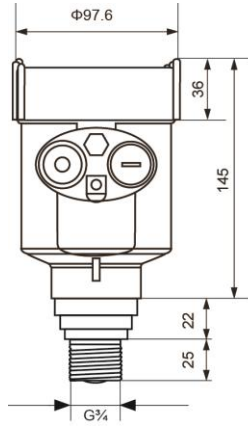

**FMW11**

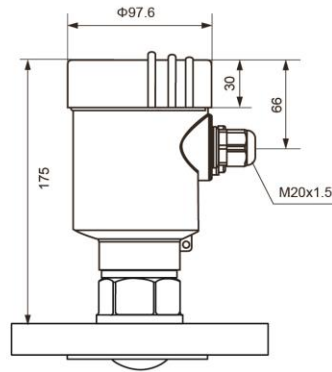
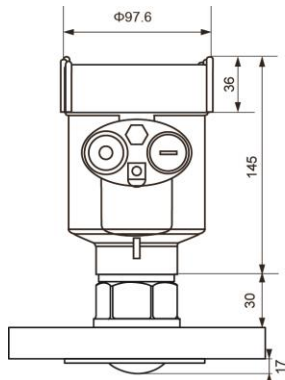
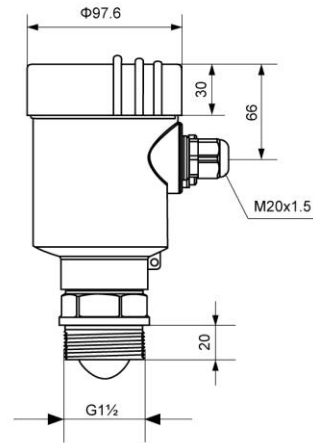
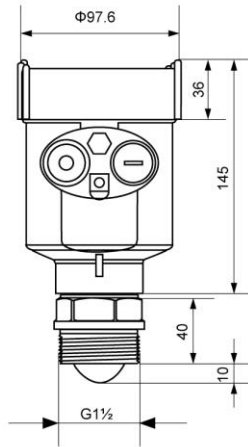

# FMW12

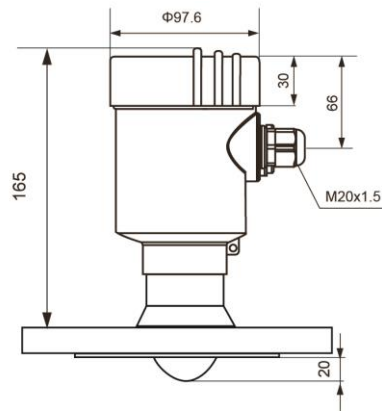
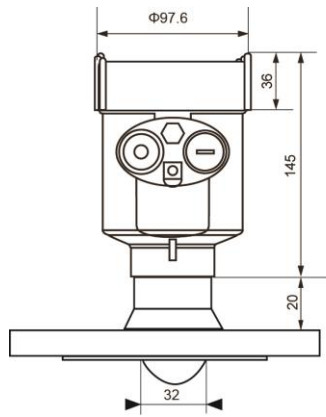

# FMW13

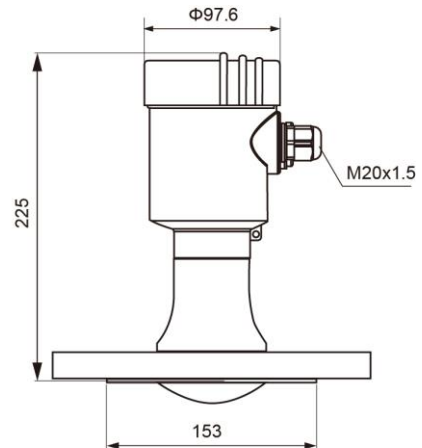
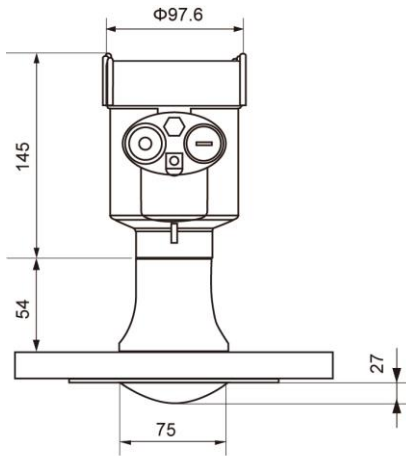

This date varies with flange size

# FMW14

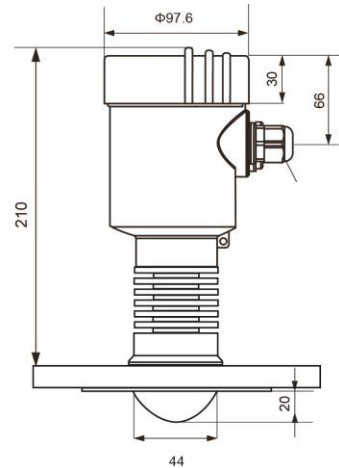
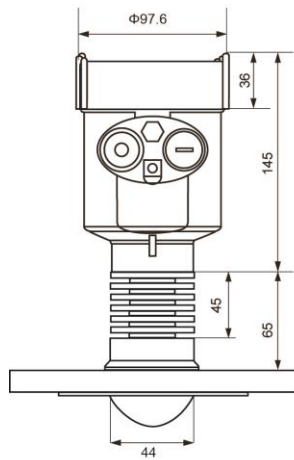

## FMW15

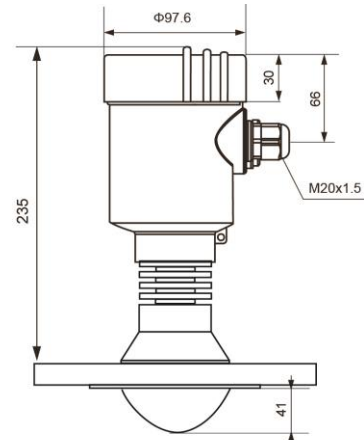
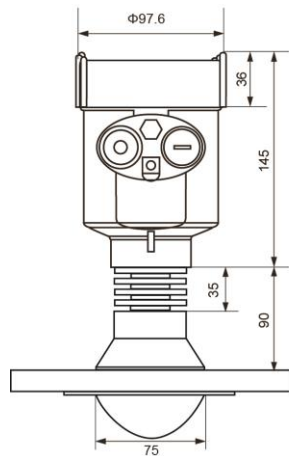

## FMW21

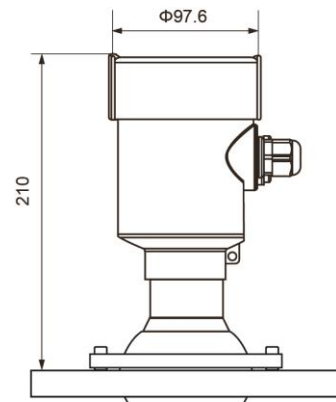
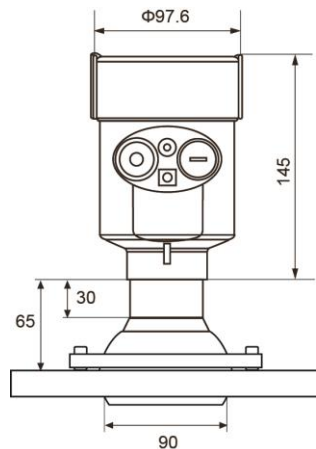

## FMW Technical Parameters:

Process Connection

Flange / material PP, PTFE, stainless steel,  
stainless steel +PTFE flanging

Antenna Material

PTFE

The outer shell

Cast aluminum / stainless steel / plastic ABS

The seal between the shell and the shell cover

Silicone rubber

Casing window

Polycarbonate

The ground terminal

Stainless steel

### Power supply pressure

2-wire system (single cavity/double cavity)

(15-28) V DC

Power dissipation max 80mA DC24V/ 2W  
 Allowable ripple <100Hz U<sub>ss</sub> < 1V  
 (100~100K) Hz U<sub>ss</sub> < 10mV  
**4-wire system (double cavity)** (198~242)V AC  
 110V AC

### Cable parameter

Cable entrance / plug 1 M20x1.5 cable entrance  
 1 blind plug M20x1.5  
 Terminal Conductor cross section 2.5mm<sup>2</sup>

### Output parameters

Output signal (4~20) mA /HART  
 Resolution 1mm  
 Fault signal current output unchanged; 20. 5mA; 22mA; 3.9mA  
 Integration time (0~20)s, adjustable  
 Blind zone 0.1m/0.2m/0.3m  
 Maximum measuring distance 150 m  
 Measurement interval 1 second (depending on parameter settings)  
 Adjustment time about 1 second (depending on parameter settings)  
 Working storage and transportation temperature (-40~80) °C  
 Relative humidity < 95%  
 Pressure Max. 2.5MPa  
 Shockproof Vibration frequency (10~150) Hz,  
 Maximum vibration acceleration 10m/s<sup>2</sup>

## FMW Meter Linearity:

- Beam angle

The beam angle is the beam angle when the radar wave energy density reaches half of its maximum value (3dB width). Microwaves emit signals outside the beam range and can be reflected by interference objects.

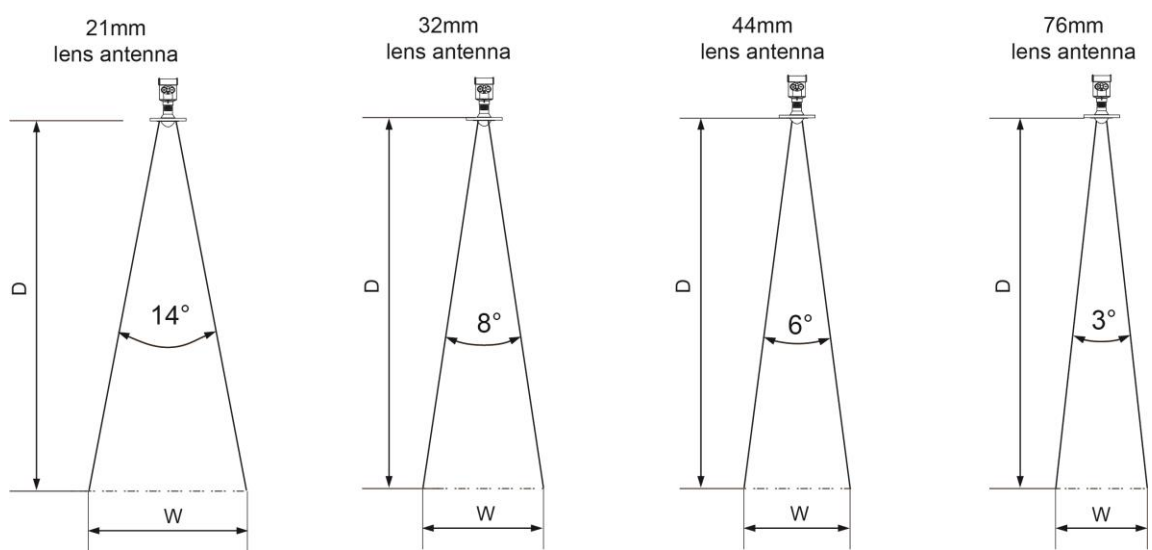

Lens antenna diameter	Φ21mm Lens antenna	Φ32mm Lens antenna	Φ44mm Lens antenna	Φ78mm Lens antenna
Beam angle	14°	8°	6°	3°

The larger the antenna size, the smaller the beam Angle alpha, the less the interference echo will be generated.

For more accurate measurements, avoid installing any internal devices (such as limit switches, temperature sensors, bases, vacuum rings, heating coils, baffles, etc.) within the signal beam range.

● Gauge linear

**FMW-11S**

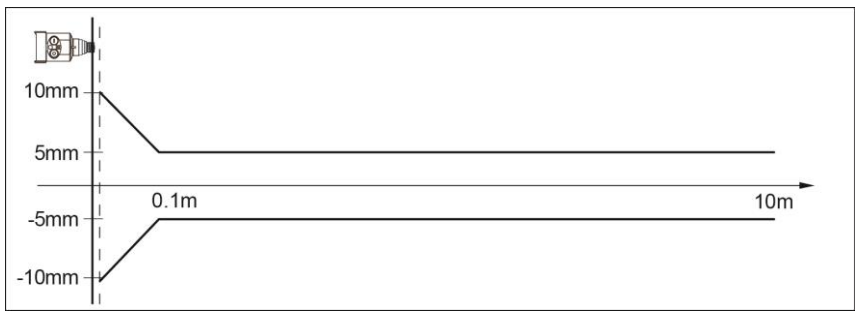

## FMW-11/FMW-12/FWM-13/FWM-14/FMW-15

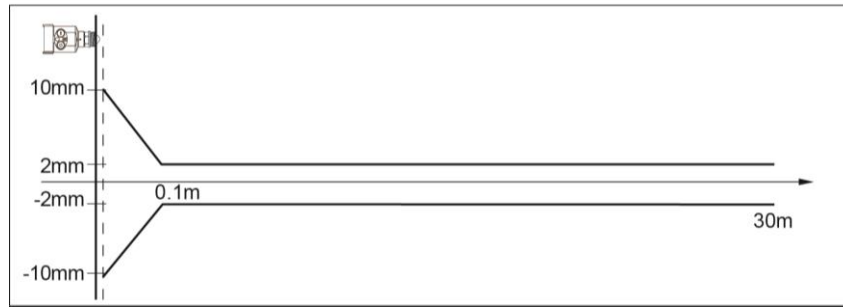

## FMW-21

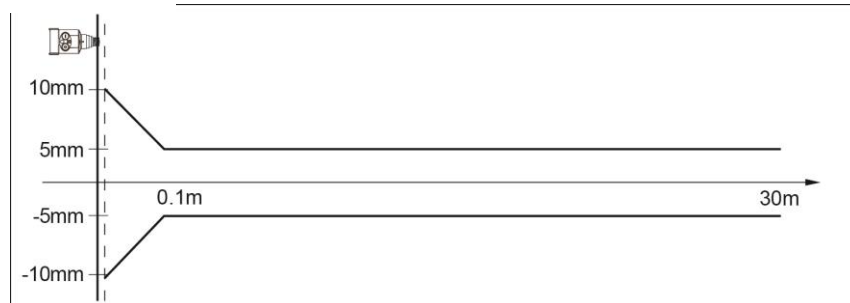

## 80G FMW Product Model Selection:

### FMW11S

#### License

- P Standard (Non-explosion-proof)
- I Intrinsically safe (Exia IIC T6 Ga)
- D Intrinsically safe+Flameproof (Exd ia IIC T6 Gb)

#### Process Connection / Material

1 G<sup>3/4</sup>Athread / <sup>3</sup>/<sub>4</sub>NPT

#### Flange option / material

Specification / Code / Material	PP	PTFE	Stainless steel304	Stainless steel316L
DN25	P1	F2	G1	S1
DN40	P2	F2	G2	S2

<b>FMW1150</b>	P3	F3	G3	S3
DN65	P4	F4	G4	S4

### Antenna Type / Material

A 21mm filled lens antenna /PTFE

B 21mm filled lens antenna /PEK

### Sealing / process temperature

A FKM/ (-40-100°C)

B PEK/ (-40-150°C)

### The Electronic Unit

1 (4~20) mA/HART protocol 24VDC 2-wire

2 (4~20) mA/HART protocol 220VAC 4-wire

3 (4~20) mA+RS485/Modbus protocol 12- 24VDC 6-wire

### Shell material/protection grade

A Cast aluminum / Single chamber / IP67

B Cast aluminum / Double chamber / IP67

C Cast aluminum / Double cavity side view / IP67

D Plastic ABS / Single chamber / IP65

E Stainless steel 304 / Single chamber / IP67

### Cable Line

M M20×l. 5

N ½" NPT

X Special customization

### Display programming

A Programming with display

B With display programming  
/ Bluetooth communication

C Without

**License**

- P Standard (Non-explosion-proof)
- I Intrinsically safe (Exia IIC T6 Ga)
- D Intrinsically safe+Flameproof (Exd ia IIC T6 Gb)

**Process Connection / Material**

- 1 G1½A thread
- 2 Flange≥DN40 (Stainless steel+PTFE)
- X Special customization

**Flange option / material**

Specification / Code / Material	PP	PTFE	Stainless steel304+PTFE	Stainless steel316L+PTFE
DN40	-	-	G1	S1
DN50	P2	F2	G2	S2
DN65	P3	F3	G3	S3
DN80	P4	F4	G4	S4
DN100	P5	F5	G5	S5
DN125	P6	F6	G6	S6
DN150	P7	F7	G7	S7

**Antenna Type / Material**

- A 32mm filled lens antenna /PTFE

**Sealing / process temperature**

- A FKM/ (-40-80°C)
- B FKM/ (-40-100°C)

**The Electronic Unit**

- 1 (4~20) mA/HART protocol 24VDC 2-wire
- 2 (4~20) mA/HART protocol 220VAC 4-wire
- 3 (4~20) mA+RS485/Modbus protocol 12- 24VDC 6-wire

**Shell material/protection grade**

- A Cast aluminum / Single chamber / IP67

- B Cast aluminum / Double chamber / IP67
- C Cast aluminum / Double cavity side view / IP67
- D Plastic ABS / Single chamber / IP65
- E Stainless steel 304 / Single chamber / IP67

**Cable Line**

- M M20xl. 5
- N ½" NPT
- X Special customization

**Display programming**

- A Programming with display
- B With display programming  
/ Bluetooth communication
- C Without

**FMW12**

**License**

- P Standard (Non-explosion-proof)
- I Intrinsically safe (Exia IIC T6 Ga)
- D Intrinsically safe+Flameproof (Exd ia IIC T6 Gb)

**Process Connection / Material**

- 1 G1½A thread/304
- 2 Flange ≥ DN40 (Stainless steel + PTFE)
- X Special customization

**Flange option / material**

Specification / Code / Material	PP	PTFE	Stainless steel304+PTFE	Stainless steel316L+PTFE
DN40	-	-	G1	S1

<b>FMW13</b> DN50	P2	F2	G2	S2
DN65	P3	F3	G3	S3
DN80	P4	F4	G4	S4
DN100	P5	F5	G5	S5
DN125	P6	F6	G6	S6
DN150	P7	F7	G7	S7

### Antenna Type / Material

A 32mm filled lens antenna /PTFE

### Sealing / process temperature

A FKM/ (-40-100°C)

### The Electronic Unit

- 1 (4~20) mA/HART protocol 24VDC 2-wire
- 2 (4~20) mA/HART protocol 220VAC 4-wire
- 3 (4~20) mA+RS485/Modbus protocol 12- 24VDC 6-wire

### Shell material/protection grade

- A Cast aluminum / Single chamber / IP67
- B Cast aluminum / Double chamber / IP67
- C Cast aluminum / Double cavity side view / IP67
- D Plastic ABS / Single chamber / IP65
- E Stainless steel 304 / Single chamber / IP67

### Cable Line

- M M20xl. 5
- N ½" NPT
- X Special customization

### Display programming

- A Programming with display
- B With display programming  
/ Bluetooth communication
- C Without

## License

- P Standard (Non-explosion-proof)
- I Intrinsically safe (Exia IIC T6 Ga)
- D Intrinsically safe+Flameproof (Exd ia IIC T6 Gb)

## Process Connection / Material

- 1 G3.5A Thread
- 2 Flange≥DN80 (Stainless steel + PTFE)
- X Special customization

## Flange option / material

Specification / Code / Material	PP	PTFE	Stainless steel304+PTFE	Stainless steel316L+PTFE
DN80	P4	F4	G4	S4
DN100	P5	F5	G5	S5
DN125	P6	F6	G6	S6
DN150	P7	F7	G7	S7

## Antenna Type / Material

- A 76mm filled lens antenna /PTFE

## Sealing / process temperature

- A FKM/ (-40-110°C)
- B EPDM/ (-40-110°C)
- Y Special customization

## The Electronic Unit

- 1 (4~20) mA/HART protocol 24VDC 2-wire
- 2 (4~20) mA/HART protocol 220VAC 4-wire
- 3 (4~20) mA+RS485/Modbus protocol 12- 24VDC 6-wire

## Shell material/protection grade

- A Cast aluminum / Single chamber / IP67
- B Cast aluminum / Double chamber / IP67
- C Cast aluminum / Double cavity side view / IP67

**FMW14**

D Plastic ABS / Single chamber / IP65

**License**

- Cable Line**
- P Standard (Non-explosion-proof)
  - I Intrinsically safe (Exia IIC T6 Ga)
  - D Intrinsically safe+Flameproof (Exd ia IIC T6 Gb)
- M M20x1.5  
N 1/2" NPT

**Process Connection / Material**

- Display programming**
- 1 Flange ≥ DN50 (Stainless steel + PTFE)
  - X Special customization
- A Programming with display  
B With display programming

**Flange option / material**

Specification / Code / Material	PP	PTFE Without	Stainless steel304+PTFE	Stainless steel316L+PTFE
DN50	-	-	G2	S2
DN65	-	-	G3	S3
DN80	-	-	G4	S4
DN100	-	-	G5	S5
DN125	-	-	G6	S6
DN150	-	-	G7	S7

**Antenna Type / Material**

A 44mm filled lens antenna/PTFE

**Sealing / process temperature**

B FKM/ (-40-200°C)

**The Electronic Unit**

- 1 (4~20) mA/HART protocol 24VDC 2-wire
- 2 (4~20) mA/HART protocol 220VAC 4-wire
- 3 (4~20) mA+RS485/Modbus protocol 12- 24VDC 6-wire

**Shell material/protection grade**

- A Cast aluminum / Single chamber / IP67
- B Cast aluminum / Double chamber / IP67
- C Cast aluminum / Double cavity side view / IP67
- D Plastic ABS / Single chamber / IP65
- E Stainless steel 304 / Single chamber / IP67

**Cable Line**

- M M20xl. 5
- N ½" NPT
- X Special customization

**Display programming**

- A Programming with display
- B With display programming  
/ Bluetooth communication
- C Without

**FMW15**

**License**

- P Standard (Non-explosion-proof)
- I Intrinsically safe (Exia IIC T6 Ga)
- D Intrinsically safe+Flameproof (Exd ia IIC T6 Gb)

**Process Connection / Material**

- 1 G3.5A Thread

2 Flange  $\geq$  DN80 (Stainless steel + PTFE)

X Special customization

### Flange option / material

Specification / Code / Material	PP	PTFE	Stainless steel304+PTFE	Stainless steel316L+PTFE
DN80	-	-	G4	S4
DN100	-	-	G5	S5
DN125	-	-	G6	S6
DN150	-	-	G7	S7

### Antenna Type / Material

A 76mm filled lens antenna/PTFE

### Sealing / process temperature

B EPDM/ (-40-200°C)

Y Special customization

### The Electronic Unit

1 (4~20) mA/HART protocol 24VDC 2-wire

2 (4~20) mA/HART protocol 220VAC 4-wire

3 (4~20) mA+RS485/Modbus protocol 12- 24VDC 6-wire

### Shell material/protection grade

A Cast aluminum / Single chamber / IP67

B Cast aluminum / Double chamber / IP67

C Cast aluminum / Double cavity side view / IP67

D Plastic ABS / Single chamber / IP65

E Stainless steel 304 / Single chamber / IP67

### Cable Line

M M20xl. 5

N 1/2" NPT

X Special customization

### Display programming

- A Programming with display
- B With display programming  
/ Bluetooth communication
- C Without

## FMW21

### License

- P Standard (Non-explosion-proof)
- I Intrinsically safe (Exia IIC T6 Ga)
- D Intrinsically safe+Flameproof (Exd ia IIC T6 Gb)

### Process Connection / Material

- 1 G3.5A Thread
- 2 Flange  $\geq$  DN80
- X Special customization

### Flange option / material

Specification / Code / Material	PP	PTFE	Stainless steel304+PTFE	Stainless steel316L+PTFE
DN80	P4	F4	G4	S4
DN100	P5	F5	G5	S5
DN125	P6	F6	G6	S6
DN150	P7	F7	G7	S7
DN200	P8	F8	G8	S8

### Antenna Type / Material

- A 76mm Lens antenna / With purge port / PE
- B 76mm Lens antenna / With purge port / PTFE

### Sealing / process temperature

- A FKM/ (-40-80°C)
- B FKM/ (-40-110°C)
- C FKM/(-40-200°C)
- Y Special customization

### **he Electronic Unit**

- 1 (4~20) mA/HART protocol 24VDC 2-wire
- 2 (4~20) mA/HART protocol 220VAC 4-wire
- 3 (4~20) mA+RS485/Modbus protocol 12- 24VDC 6-wire

### **Shell material/protection grade**

- A Cast aluminum / Single chamber / IP67
- B Cast aluminum / Double chamber / IP67
- C Cast aluminum / Double cavity side view / IP67
- D Plastic ABS / Single chamber / IP65
- E Stainless steel 304 / Single chamber / IP67

### **Cable Line**

- M M20xl. 5
- N 1/2" NPT
- X Special customization

### **Display programming**

- A Programming with display
- B With display programming  
/ Bluetooth communication
- C Without