

LINHA ELETRÔNICA

Injetores Common Rail

Bosch CRI CRI 1.0 CRI 2.0 CRI 2.2	02
Bosch CRI 2.5	08
Bosch CRIN 1	12
Bosch CRIN 2	18
Volvo CRIN 2 EURO 5	19
Bosch CRIN 3	20
Bosch CRIN 4.2	27
Caterpillar C4 C6	29
Cummins ISX 15 XPI - Scania	33
Cummins ISL - Scania	37
Daf MX13	39
Delphi HR	41
Delphi JCB	43
Denso G2	45
Denso G2 G3	49
Siemens VDO Continental	54

Bonalli

57

Bombas de Alta Pressão Common Rail

Bosch CP1	67
Bosch CP1H	71
Bosch CP3 0 445 020 046	75
Bosch CP3 0 445 010 033	79
Bosch CP3 0 445 020 033	83
Bosch CP3 0 445 020 129	89
Bosch CP3 0 445 020 005	93
Bosch CP4	97
Caterpillar C4 C6	99
Cummins CP2	102
Cummins XPI	105
Delphi - HR Sprinter	108
Denso HP3	110
Denso HP4	112
Siemens	114

Unidades EUP

PLD MBB Menores	117
PLD MBB Maiores	123
Volvo	129

Unidades EUI

Bosch E1 - Euro 5- Iveco	134
Bosch EUI PDE- Scania Iveco	136
Caterpillar C10 C12	144
Caterpillar C13 C15	148
Caterpillar C15 C32	150
Caterpillar 3500	154
Cummins N14 M11	158
Delphi A1 A2 - Volvo D12 A C	161
Delphi E1 - Volvo D12D	167
John Deere E1	170
Delphi E3 - Volvo D13	174
Delphi E3 - Freightliner	177
Detroit Série 60 N2	179
Detroit Série 60 N3	181
Daf MX13	184
Cummins ISX - Scania 470 HPI	186

Unidades HEUI

Caterpillar C7 C9	188
Caterpillar 3126B/E	194
Navistar DT466E	197
Caterpillar 3126A	200
Navistar G2.8	203
Navistar G2.9	205

Bombas Alimentadoras

MBB 712	208
MBB 1933	210
MBB 1938	212
MBB Série 900	214
Scania	216
Volvo D12C	218
Volvo D13	220

Bombas HEUI

Caterpillar C7/C9	222
Stanadyne	225

Ferramentas

Kits de Reparação	228
Ferramentas com Ponteiros Intercambiáveis	254
Aplicações Gerais	270
Bombas de Alta Pressão	273
Injetores Common Rail	274
Unidades	275
Bombas Alimentadoras	276

ROBIEL[®]

A **ROBIEL**[®] permanece no desafio de oferecer, dia após dia, às oficinas do Brasil e do mundo: componentes, ferramentas, capacitação e equipamentos que aumentem a produtividade, reduzam custos e otimizem o tempo de trabalho durante a reparação de sistemas de injeção diesel.

SOMOS **FABRICANTES**

Estamos sempre focados em atender as necessidades do mercado e principalmente contribuir no crescimento dos nossos clientes, trabalhamos lado a lado a fim de atender suas necessidades e entregar as melhores soluções para atender da melhor forma e simplificar a rotina de sua oficina.

Para que possamos oferecer o melhor custo benefício, trazer maior praticidade e agilidade aos processos de reparação e possibilitar uma maior lucratividade para o seu negócio, nossos produtos passam por diversas etapas antes de chegar ao mercado.



ROBIEL®

INJETORES COMMON RAIL

Bosch CRI | CRI 1.0 | CRI 2.0 | CRI 2.2

Volvo Renault

Bosch CRI 2.5

Bosch CRIN 1

Bosch CRIN 2 | CRIN 3

Bosch CRIN 4.2

Caterpillar C4 | C6

Cummins ISX 15 | XPI - Scania

Cummins ISL - Scania

Daf MX13

Delphi HR

Delphi JCB

Denso G2

Denso G2 | G3

Siemens VDO | Continental

UTILIZE A CÂMERA DO SEU CELULAR PARA ESCANEAR O QR CODE E OBTER MAIS INFORMAÇÕES TÉCNICAS DOS PRODUTOS EM NOSSO APLICATIVO **ROBIEL**

BAIXE NOSSO NOVO APP



INJETORES CRI | CRI1.0 | CRI2.0 | CRI2.2

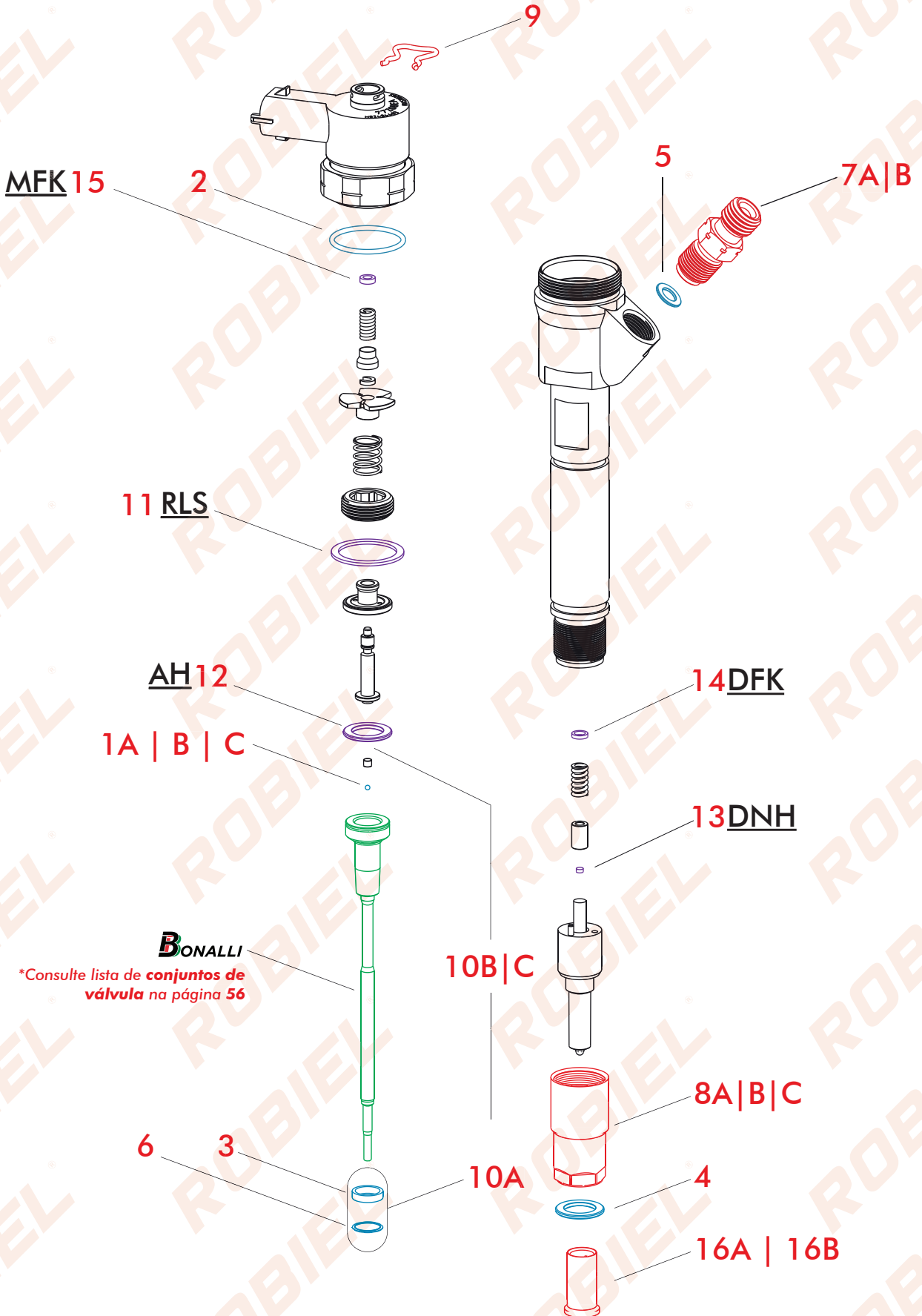

410.00.26

REPARO INJETOR COMMON RAIL CRI 1.0 ESFERA Ø1,3mm SPRINTER - COMPLETO

CÓD. REFERÊNCIA				
Nº	CÓD. ROBIEL	REFERÊNCIA	DESCRIÇÃO	EMB.
1A	190.50.11	F 00V C05 001	Esfera	01pç.
2	421.02.115	F 00V C38 002	Anel	01pç.
3	424.08.10	F 00V C99 002	Anel de Teflon	01pç.
4	600.02.02	1 987 972 076 A611 01 70 060	Arruela	01pç.
5	805.09.05	F 00V C17 003	Arruela de Vedação 5,0 x 10,0	01pç.
6	808.10.010	F 00V C99 002	Anel de Aço	01pç.



* Reparo também aplicado nos injetores 0 445 110 248 e 0 445 110 273 porém é necessário substituir a esfera 190.50.11 pela esfera 190.50.14.

PEÇAS AVULSAS

Nº	CÓD. ROBIEL	REFERÊNCIA	DESCRIÇÃO	EMB.
1A	190.50.11	F 00V C05 001	Esfera do Injetor Common Rail Ø 1,34mm	12pç.
1B	190.50.14	F 00V C05 009 006	Esfera dos Injetores 0 445 120 248 273 - Ø 1,50mm	12pç.
1C	190.52.02	-	Esfera Cerâmica Ø 1,50mm	12pç.
4	600.02.02	1 987 972 076 A611 01 70 060	Arruela do Bico Injetor Common Rail	24pç.
5	805.09.05	F 00V C17 003	Calço da Conexão Common Rail	12pç.
7A	165.02.06	F 00V C16 017	Conexão da Pressão do Injetor <small>M12X 1,50mm M12 X 1,00mm</small>	01pç.
7B	165.02.061	-	Conexão c/ Microfiltro Injetores Bosch Siemens	01pç.
8A	315.06.25	F 00V C14 012	Porca do Bico Sprinter 311 CDI <small>M17 X 0,75mm</small>	04pç.
8B	315.06.58	F 00V C14 015	Porca do Bico Ducato <small>M17 X 0,75mm</small>	01pç.
8C	315.06.64	-	Porca do Bico - Hyundai Kia 2.0 2.2 (Rosca Esquerda)	06pç.
9	335.05.06	F 00V C22 003	Trava do Retorno Sprinter 313 CDI	12pç.
10A	424.08.10C	F 00V C99 002	Reparo do Bastão	04ig.
10B	424.08.10D	F 00V C22 003 + Esfera	Reparo do Bastão com Esfera Ø1,34mm	01ig.
10C	424.08.10E	F 00V C99 002 + Esfera	Reparo do Bastão com Esfera Ø1,50mm	01ig.
16A	220.03.08	F 00R J02 537 F 00R J03 561 6.000.900.262	Capa Protetora do Bico Injetor Ø 7,00mm	01ct.
16B	220.03.09	F 00H 410 849 F 002 C88 080 6.000.900.076	Capa Protetora do Bico Injetor Ø 9,00mm	01ct.
R1	001.08.000	6013.001.121.000	Retorno dos Bicos Volare Motor Sprint 2.7	01pç.
R2	001.08.432	A 611 070 8432	Retorno dos Bicos Sprinter 313 CDI	01pç.
R3	421.00.412	-	Anel da Conexão do Retorno dos Bicos	24pç.
R4	165.06.10	-	Conexão "T" do Retorno dos Bicos	04pç.
R5	165.06.11	-	Conexão "L" do Retorno dos Bicos	04pc.
R6	002.70.0533	-	Cano da Bomba ao Rail Sprinter CDI	01pç.
R7	002.70.0233	611 070 0233	Cano dos Bicos Sprinter CDI	01pç.



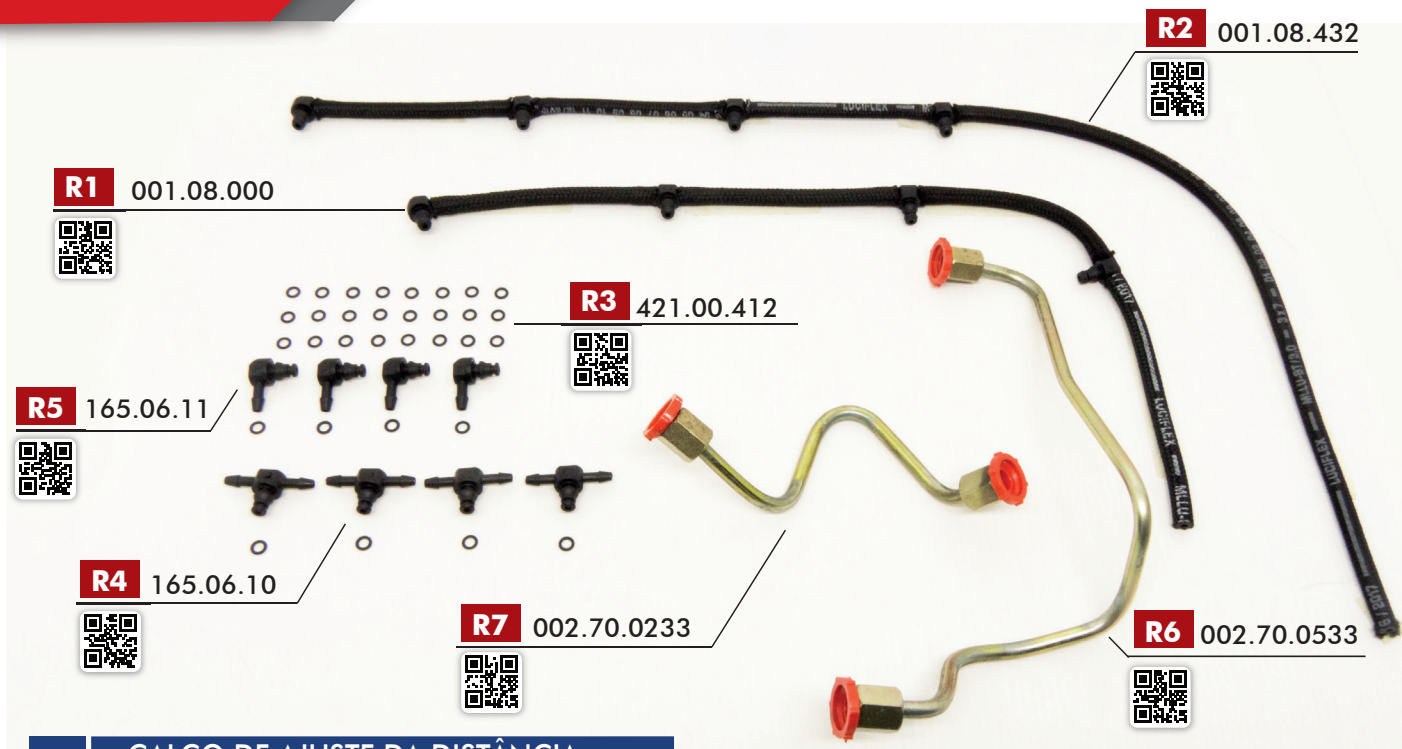

11

CALÇO DE AJUSTE DA DISTÂNCIA ENTRE BOBINA E INDUZIDO (RLS)

Ø Interno: 19,00 Ø Externo: 23,80



CÓD. ROBIEL	REFERÊNCIA	ESPESSURA(mm)
819.25.094	F 00V C60 215	0,94
819.25.095	F 00V C60 221	0,95
819.25.096	F 00V C60 225	0,96
819.25.097	-	0,97
819.25.098	F 00V C60 235	0,98
819.25.099	-	0,99
819.25.100	F 00V C60 245	1,00
819.25.101	-	1,01
819.25.102	F 00V C60 255	1,02
819.25.103	-	1,03
819.25.104	F 00V C60 265	1,04
819.25.105	F 00V C60 270	1,05
819.25.106	F 00V C60 275	1,06
819.25.107	F 00V C60 280	1,07
819.25.108	F 00V C60 285	1,08
819.25.109	-	1,09
819.25.110	F 00V C60 295	1,10
819.25.112	-	1,12
819.25.114	-	1,14
819.25.116	-	1,16
819.25.118	-	1,18
819.25.120	-	1,20
819.25.122	-	1,22
819.25.124	-	1,24
819.25.202	-	2,02
819.25.205	-	2,05

EMBALAGEM COM 04 PEÇAS

12

CALÇO DE AJUSTE DA FOLGA DO CURSO DA MICRO ESFERA (AH)

Ø Interno: 10,40 Ø Externo: 15,80



CÓD. ROBIEL	REFERÊNCIA	ESPESSURA(mm)
810.16.117	-	1,17
810.16.120	F 00V C10 406	1,20
810.16.121	F 00V C10 410	1,21
810.16.122	F 00V C10 416	1,22
810.16.123	F 00V C10 420	1,23
810.16.124	F 00V C10 426	1,24
810.16.125	F 00V C10 430	1,25
810.16.126	F 00V C10 436	1,26
810.16.127	F 00V C10 440	1,27

EMBALAGEM COM 04 PEÇAS

15

CALÇO DA FORÇA DA MOLDA DA BOBINA INJETORES CRI 1.0 (MFK)

Ø Interno: 3,50 Ø Externo: 5,30



CÓD. ROBIEL	REFERÊNCIA	ESPESSURA(mm)
803.05.155	F 00V C10 514	1,55
803.05.16	F 00V C10 520	1,60
803.05.165	F 00V C10 524	1,65
803.05.17	F 00V C10 530	1,70
803.05.175	F 00V C10 534	1,75
803.05.18	F 00V C10 540	1,80
803.05.19	F 00V C10 550	1,90
803.05.20	F 00V C10 560	2,00

EMBALAGEM COM 06 PEÇAS

13
CALÇO DO AJUSTE DO CURSO DA AGULHA DO BICO (DNH)

Ø Externo: 2,30



CÓD. ROBIEL	REFERÊNCIA	ESPESSURA(mm)
800.02.100	F 00V C12 500	1,00
800.02.101	F 00V C12 502	1,01
800.02.102	F 00V C12 504	1,02
800.02.103	F 00V C12 506	1,03
800.02.104	F 00V C12 508	1,04
800.02.105	F 00V C12 510	1,05
800.02.106	F 00V C12 512	1,06
800.02.107	F 00V C12 514	1,07
800.02.108	F 00V C12 516	1,08
800.02.109	F 00V C12 518	1,09
800.02.110	F 00V C12 520	1,10
800.02.111	F 00V C12 522	1,11
800.02.112	F 00V C12 524	1,12
800.02.113	F 00V C12 526	1,13
800.02.114	F 00V C12 528	1,14
800.02.115	F 00V C12 530	1,15
800.02.116	F 00V C12 532	1,16
800.02.117	F 00V C12 534	1,17
800.02.118	F 00V C12 536	1,18
800.02.119	F 00V C12 538	1,19
800.02.120	F 00V C12 540	1,20
800.02.121	F 00V C12 542	1,21
800.02.122	F 00V C12 544	1,22
800.02.123	F 00V C12 546	1,23
800.02.124	F 00V C12 548	1,24
800.02.125	F 00V C12 550	1,25
800.02.126	-	1,26
800.02.127	-	1,27
800.02.128	-	1,28
800.02.129	-	1,29
800.02.130	-	1,30
800.02.131	-	1,31
800.02.132	-	1,32
800.02.133	-	1,33
800.02.134	-	1,34
800.02.135	-	1,35
800.02.138	-	1,38
800.02.140	-	1,40

EMBALAGEM COM 06 PEÇAS
14
CALÇO DA FORÇA DA MOLDA DA BOBINA INJETOR (DFK)

Ø Interno: 3,50 Ø Externo: 5,30



CÓD. ROBIEL	REFERÊNCIA	ESPESSURA(mm)
803.05.07	-	0,70
803.05.075	-	0,75
803.05.08		0,80
803.05.085		0,85
803.05.09		0,90
803.05.095		0,95
803.05.10	F 00V C10 460	1,00
803.05.105	F 00V C10 464	1,05
803.05.11	F 00V C10 470	1,10
803.05.115	F 00V C10 474	1,15
803.05.12	F 00V C10 480	1,20
803.05.125	F 00V C10 484	1,25
803.05.13	F 00V C10 490	1,30
803.05.135	F 00V G10 494	1,35
803.05.14	F 00V C10 500	1,40
803.05.145	F 00V C10 504	1,45
803.05.15	F 00V C10 510	1,50
803.05.155		1,55
803.05.16		1,60
803.05.165		1,65
803.05.17		1,70
803.05.175		1,75
803.05.18		1,95
803.05.19		1,90
803.05.20		2,00

EMBALAGEM COM 06 PEÇAS
15
CALÇO DA MOLDA DA BOBINA DOS INJETORES CRI 2.0 | 2.2 (MFK)

Ø Interno: 2,80 Ø Externo: 5,00



CÓD. ROBIEL	REFERÊNCIA	ESPESSURA(mm)
803.06.140	F 00V C60 590	1,40
803.06.144	F 00V C60 594	1,44
803.06.148	F 00V C60 598	1,48
803.06.152	F 00V C60 602	1,52
803.06.156	F 00V C60 606	1,56
803.06.160	F 00V C60 610	1,60
803.06.200	-	2,00

EMBALAGEM COM 12 PEÇAS

415.00.011

KIT DE CALÇOS PARA REPARAÇÃO DE INJETORES CRI | CRIN

Nº	CÓDIGOS	DESCRIÇÃO	ESPESSURAS(mm)	Peças por Medida
-	305.20.830 - 305.20.849	Top do Injetor MWM	8,30 à 8,49	12 peças
-	305.30.834 - 305.30.855	Top do Injetor Cummins Ducato	8,34 à 8,55	12 peças
DNH	800.02.100 - 800.02.125	Calço Restritor do Bico Common Rail	1,00 à 1,25	12 peças
-	802.04.10 - 5	Calço da Pré-Injeção MWM Cummins	1,00 à 1,25	12 peças
DFK	803.05.12 - 803.05.19	Calço do Bico Injetor CR Piezo	1,20 à 1,90	12 peças
MFK	803.06.140 - 803.06.160	Calço da Bobina do Injetor CR Iveco	1,40 à 1,60	12 peças
AH	810.16.117 - 810.16.127	Calço de Pressão Common Rail Sprinter	1,17 à 1,27	12 peças
-	818.24.092 - 818.24.103	Calço do Regulador Common Rail CP3	0,92 à 1,03	12 peças
-	819.24.125 - 819.24.135	Calço do Regulador Common Rail CP3	1,25 à 1,35	12 peças
RLS	819.25.094 - 819.25.110	Calço do Ajuste de Débito CR	0,94 à 1,10	12 peças

TOTAL DE 1740 PEÇAS

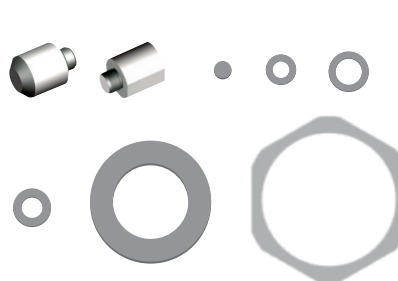

323.01.3241

Morsa Giratória para Bancada com Pino Trava



324.15.01

Suporte de Montagem e Desmontagem de Injetores



324.10.10

Chave da Bucha de Fixação da Válvula 248/273



323.02.121

Escova para Limpeza e Remoção de Resíduos Ø 12,00mm



323.50.072

Kit de Ferramentas para Reparação de Injetores Bosch CRI 1.0 / 2.0 / 2.2 CRIN 1 / 1.16



323.02.29

Ferramenta de Teste da Válvula Bastão Common Rail



UTILIZE A CÂMERA DO SEU CELULAR PARA ESCANEAR O QR CODE E OBTER MAIS INFORMAÇÕES TÉCNICAS DOS PRODUTOS EM NOSSO APLICATIVO **ROBIEL**

BAIXE NOSSO NOVO APP



INJETORES CRI 2.5

Amarok

INJETORES

0 445 110 369

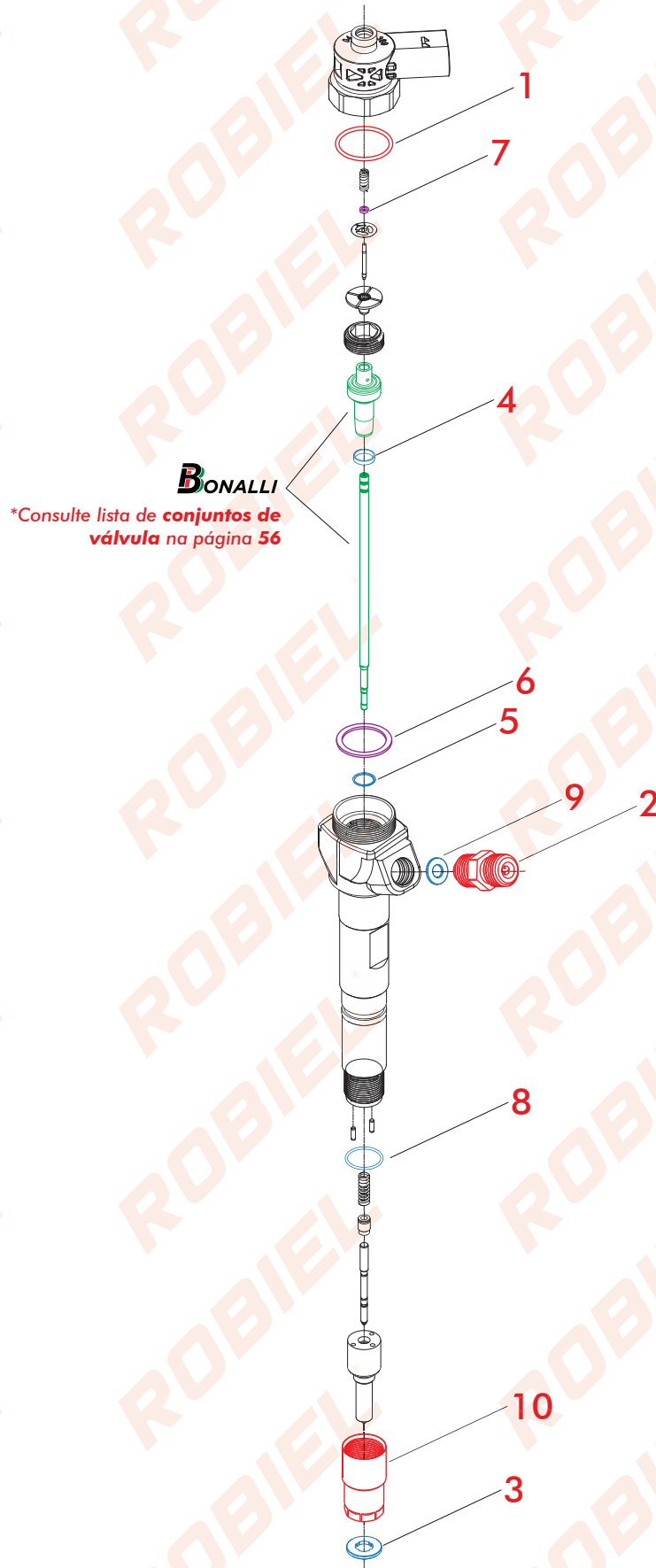

410.08.369 REPARO DO INJETOR AMAROK - COMPLETO				
CÓD. REFERÊNCIA				
Nº	CÓD. ROBIEL	REFERÊNCIA	DESCRIÇÃO	EMB.
1	421.02.115	F 00V C38 002	Anel Oring	01pç.
3	607.13.15	F 00V P01 004	Arruela do Bico	01pç.
4	424.08.10	F 00V C99 002	Anel de Teflon	01pç.
5	808.10.010	F 00V C99 002	Anel de Aço	01pç.
8	421.16.15	-	Anel Oring	01pç.



410.08.001 REPARO EXTERNO DO INJETOR AMAROK				
CÓD. REFERÊNCIA				
Nº	CÓD. ROBIEL	REFERÊNCIA	DESCRIÇÃO	EMB.
3	607.13.15	F 00V P01 004	Arruela do Bico	04pç.
8	421.16.15	-	Anel Oring	04pç.



424.08.10C REPARO DO BASTÃO INJETOR COMMON RAIL				
CÓD. REFERÊNCIA				
Nº	CÓD. ROBIEL	REFERÊNCIA	DESCRIÇÃO	EMB.
4	424.08.10	F 00V C99 002	Anel de Teflon	04pç.
5	808.10.010	F 00V C99 002	Anel de Aço	04pç.



PEÇAS AVULSAS

Nº	CÓD. ROBIEL	REFERÊNCIA	DESCRIÇÃO	EMB.
1	421.02.115	F 00V C38 002	Anel do Solenoide Common Rail	06pç.
2	165.02.17	F 00V C16 501	Conexão com Micro Filtro - Injetor Amarok	01pç.
3	607.13.15	F 00V P01 004	Arruela do Bico Injetor Common Rail - Amarok	06pç.
9	806.12.100	-	Arruela da Conexão Injetor Common Rail - Amarok	12pç.
10	315.06.62	-	Porca do Bico - Amarok	04pç.



6
**CALÇO DE AJUSTE DA DISTÂNCIA
ENTRE BOBINA E INDUZIDO (RLS)**

Ø Interno: 19,00 Ø Externo: 23,80



CÓD. ROBIEL	REFERÊNCIA	ESPESSURA(mm)
819.25.094	F 00V C60 215	0,94
819.25.095	F 00V C60 221	0,95
819.25.096	F 00V C60 225	0,96
819.25.097	-	0,97
819.25.098	F 00V C60 235	0,98
819.25.099	-	0,99
819.25.100	F 00V C60 245	1,00
819.25.101	-	1,01
819.25.102	F 00V C60 255	1,02
819.25.103	-	1,03
819.25.104	F 00V C60 265	1,04
819.25.105	F 00V C60 270	1,05
819.25.106	F 00V C60 275	1,06
819.25.107	F 00V C60 280	1,07
819.25.108	F 00V C60 285	1,08
819.25.109	-	1,09
819.25.110	F 00V C60 295	1,10
819.25.112	-	1,12
819.25.114	-	1,14
819.25.116	-	1,16
819.25.118	-	1,18
819.25.120	-	1,20
819.25.122	-	1,22
819.25.124	-	1,24
819.25.202	-	2,02
819.25.205	-	2,05

EMBALAGEM COM 04 PEÇAS
7
**CALÇO DA FORÇA DA
MOLA DA BOBINA (MFK)**

Ø Interno: 2,25 Ø Externo: 4,00



CÓD. ROBIEL	REFERÊNCIA	ESPESSURA(mm)
802.04.10	F 00R J04 649	1,00
802.04.105	F 00R J04 651	1,05
802.04.11	F 00R J04 652	1,10
802.04.115	F 00R J04 654	1,15
802.04.12	F 00R J04 656	1,20
802.04.125	F 00R J04 657	1,25
802.04.13	F 00R J04 659	1,30
802.04.135	F 00R J04 661	1,35
802.04.14	F 00R J04 662	1,40
802.04.145	F 00R J04 664	1,45
802.04.15	F 00R J04 666	1,50
802.04.155	F 00R J04 667	1,55
802.04.16	F 00R J04 669	1,60
802.04.165	-	1,65
802.04.17	-	1,70

EMBALAGEM COM 06 PEÇAS

CONVERTA CÓDIGOS ORIGINAIS EM CÓDIGOS **ROBIEL**

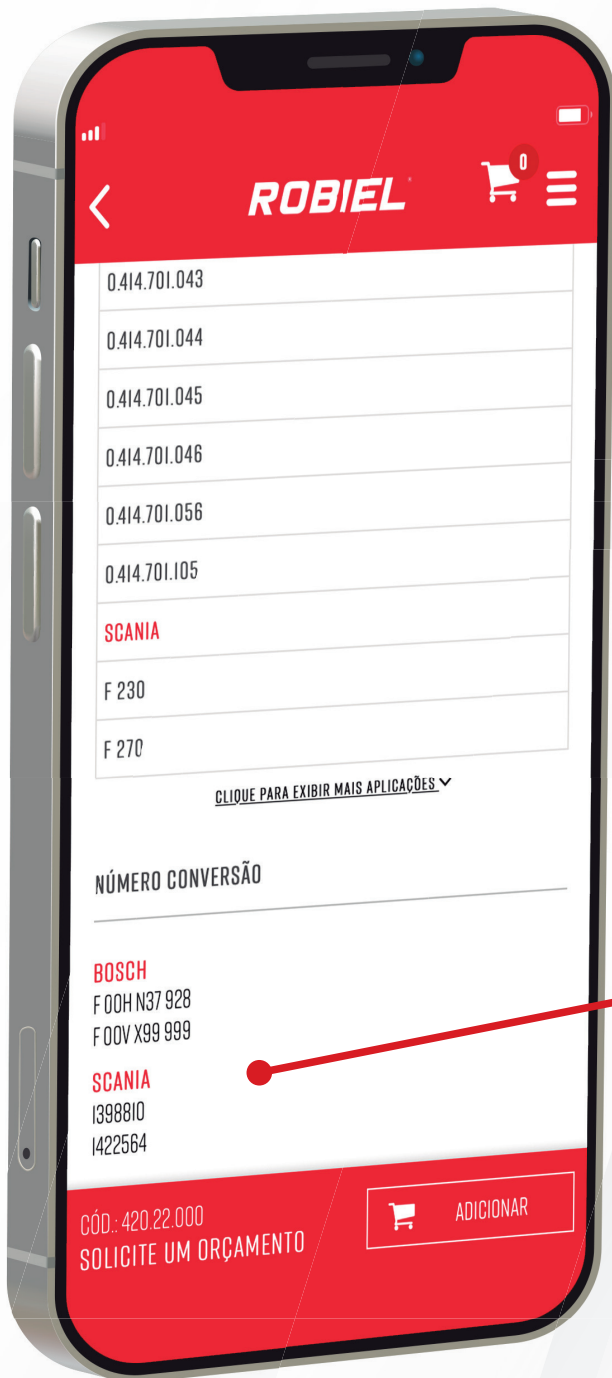

BAIXE AGORA!



WWW.ROBIEL.COM

UTILIZE A CÂMERA DO SEU CELULAR PARA ESCANEAR O QR CODE E OBTER MAIS **INFORMAÇÕES TÉCNICAS** DOS PRODUTOS EM NOSSO APLICATIVO **ROBIEL**

BAIXE NOSSO NOVO APP



INJETORES CRIN

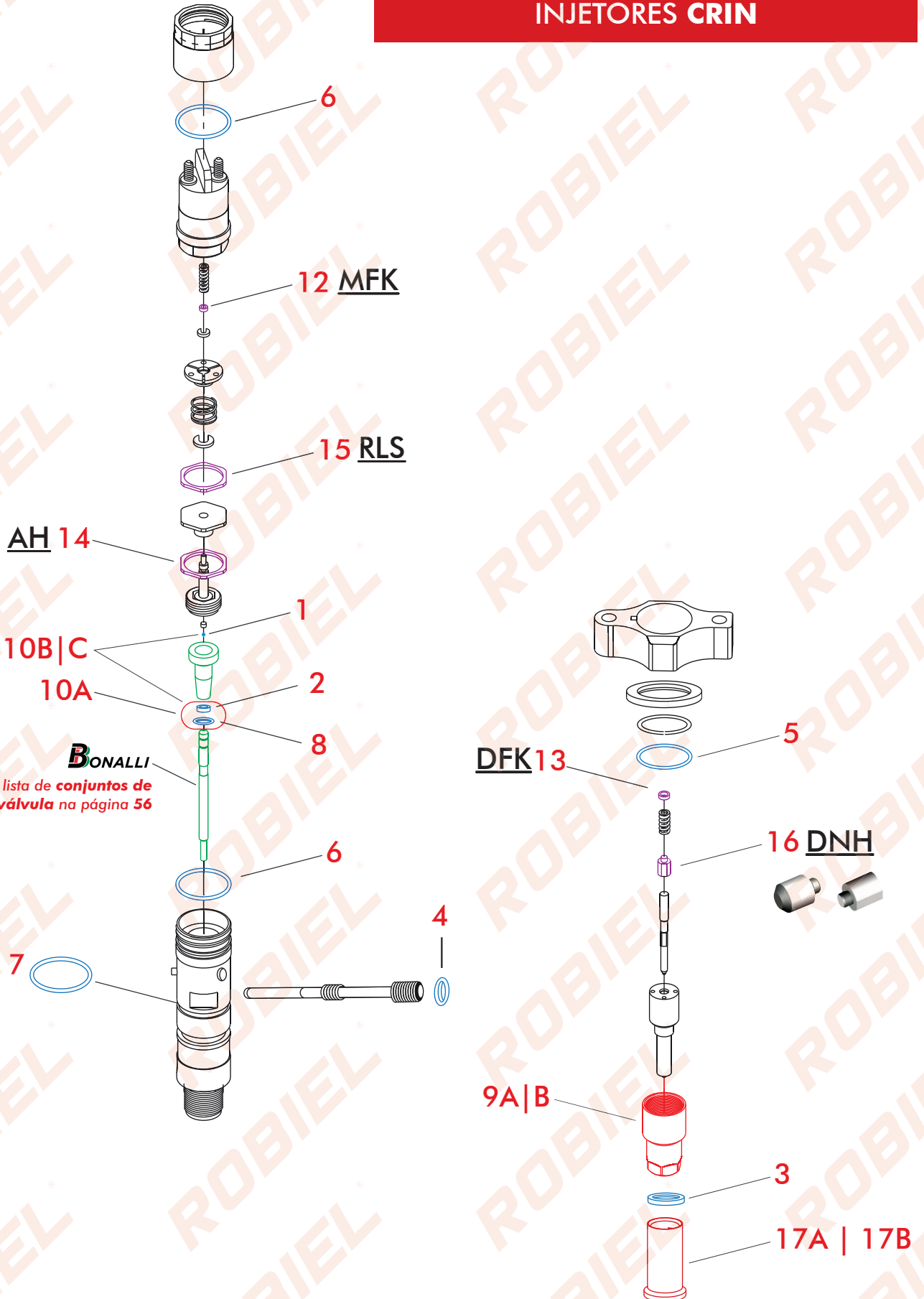

410.00.281 REPARO DO INJETOR CRIN - MWM				
CÓD. REFERÊNCIA				
Nº	CÓD. ROBIEL	REFERÊNCIA	DESCRIÇÃO	EMB.
1	190.50.11	F 00V C05 001	Esfera	01pç.
2	424.08.10	F 00V C99 002	Anel de Teflon	01pç.
3	600.02.08	F 00V C17 505 F 00R J01 086	Arruela 7,00x15,00x2,00	01pç.
6	421.02.415	F 00R J00 220	Anel	02pç.
7	421.01.720	-	Anel	01pç.
8	808.10.010	-	Calço	01pç.



410.00.29 REPARO DO INJETOR CRIN - CUMMINS				
CÓD. REFERÊNCIA				
Nº	CÓD. ROBIEL	REFERÊNCIA	DESCRIÇÃO	EMB.
1	190.50.11	F 00V C05 001	Esfera	01pç.
2	424.08.10	F 00V C99 002	Anel de Teflon	01pç.
3	600.02.07	F 00V C17 503 F 00R J01 453	Arruela 7,00x15,00x1,50	01pç.
4	421.01.130	A5419970545	Anel	01pç.
5	421.02.130	A5419970645	Anel	01pç.
6	421.02.415	F 00R J00 220	Anel	02pç.
8	808.10.010	-	Calço	01pç.



PEÇAS AVULSAS

Nº	CÓD. ROBIEL	REFERÊNCIA	DESCRIÇÃO	EMB.
1	190.50.11	F 00V C05 001	Esfera do Injetor Common Rail Ø1,34mm	12pç.
3A	600.02.07	F 00V C17 503 F 00R J01 453	Arruela do Porta Injetor Common Rail Cummins - 1,50mm	24pç.
3B	600.02.08	F 00V C17 505 F 00R J01 086	Arruela do Porta Injetor Common Rail MWM - 2,00mm	24pç.
4	421.01.130	2 430 210 082 A5419970545	Anel da Conexão	10pç.
5	421.02.130	2 430 210 081 A5419970645	Anel do Porta Injetor	10pç.
9A	315.06.32	F 00R J00 841	Porca do Bico do Injetor Cummins CP3 - M19 X 0,75mm	01pç.
9B	315.06.56	F 00R J00 713 F 00R J02 219	Porca do Bico do Injetor MWM 4.12 TCE - M19 X 0,75mm	04pç.
10A	424.08.10C	F 00V C38 002 F 00R J02 176 F 00V C99 002	Reparo do Bastão	04ig.
10B	424.08.10D	F 00V C99 002 + Esfera	Reparo do Bastão com Esfera Ø1,34mm	01ig.
10C	424.08.10E	F 00V C99 002 + Esfera	Reparo do Bastão com Esfera Ø1,50mm	01ig.
11A	165.02.15	Injetores c/ Caneta	Conexão com Microfiltro CR Delphi Bosch - M14x1,50mm	01pç.
11B	165.02.16	Injetores s/ Caneta	Conexão com Microfiltro Injetores CR MWM - M14x1,50mm	01pç.
17A	220.03.08	F 00R J02 537 F 00R J03 561 6.000.900.262	Capa Protetora do Bico Injetor Ø 7,00mm	01ct.
17B	220.03.09	F 00H 410 849 F 002 C88 080 6.000.900.076	Capa Protetora do Bico Injetor Ø 9,00mm	01ct.





12	CALÇO DA FORÇA DA MOLA DA BOBINA (MFK)		
	Ø Interno: 2,25 Ø Externo: 4,00		
○	CÓD. ROBIEL	REFERÊNCIA	ESPESSURA(mm)
	802.04.10	F 00R J04 649	1,00
	802.04.105	F 00R J04 651	1,05
	802.04.11	F 00R J04 652	1,10
	802.04.115	F 00R J04 654	1,15
	802.04.12	F 00R J04 656	1,20
	802.04.125	F 00R J04 657	1,25
	802.04.13	F 00R J04 659	1,30
	802.04.135	F 00R J04 661	1,35
	802.04.14	F 00R J04 662	1,40
	802.04.145	F 00R J04 664	1,45
	802.04.15	F 00R J04 666	1,50
	802.04.155	F 00R J04 667	1,55
	802.04.16	F 00R J04 669	1,60
	802.04.165	-	1,65
	802.04.17	-	1,70
EMBALAGEM COM 06 PEÇAS			

13	CALÇO DA FORÇA DA MOLA DA BOBINA INJETOR (DFK)		
	Ø Interno: 3,50 Ø Externo: 5,30		
○	CÓD. ROBIEL	REFERÊNCIA	ESPESSURA(mm)
	803.05.07	-	0,70
	803.05.075	-	0,75
	803.05.08		0,80
	803.05.085		0,85
	803.05.09		0,90
	803.05.095		0,95
	803.05.10	F 00V C10 460	1,00
	803.05.105	F 00V C10 464	1,05
	803.05.11	F 00V C10 470	1,10
	803.05.115	F 00V C10 474	1,15
	803.05.12	F 00V C10 480	1,20
	803.05.125	F 00V C10 484	1,25
	803.05.13	F 00V C10 490	1,30
	803.05.135	F 00V C10 494	1,35
	803.05.14	F 00V C10 500	1,40
	803.05.145	F 00V C10 504	1,45
	803.05.15	F 00V C10 510	1,50
	803.05.155		1,55
	803.05.16		1,60
	803.05.165		1,65
	803.05.17		1,70
	803.05.175		1,75
	803.05.18		1,95
	803.05.19		1,90
	803.05.20		2,00
EMBALAGEM COM 06 PEÇAS			

TABELA DE INJETORES

Restritor	Restritor	Restritor	Restritor	Restritor	Restritor	Restritor	Pino Intermediário	Pino Intermediário	Pino Intermediário
CRIN 1 1.6	CRIN 1 1.6	CRIN 1 1.6	CRIN 1 1.6	CRIN 1 1.6	CRIN 1 1.6	CRIN 1 1.6	CRIN 1 1.6	CRIN 1 1.6	CRIN 1 1.6
0 445 120 025	0 445 120 040	0 445 120 108	0 445 120 133	0 445 120 208	0 445 120 250	0 445 120 330	0 445 120 009	0 445 120 119	0 445 120 079
0 445 120 029	0 445 120 041	0 445 120 112	0 445 120 140	0 445 120 209	0 445 120 251	Pino Intermediário	0 445 120 010	0 445 120 020	0 445 120 084
0 445 120 031	0 445 120 051	0 445 120 115	0 445 120 144	0 445 120 210	0 445 120 252	CRIN 1 1.6	0 445 120 011	0 445 120 021	0 445 120 085
0 445 120 033	0 445 120 052	0 445 120 119	0 445 120 151	0 445 120 211	0 445 120 253	0 445 120 002	0 445 120 012	0 445 120 022	0 445 120 089
0 445 120 034	0 445 120 059	0 445 120 120	0 445 120 152	0 445 120 212	0 445 120 254	0 445 120 003	0 445 120 013	0 445 120 028	0 445 120 103
0 445 120 035	0 445 120 060	0 445 120 121	0 445 120 159	0 445 120 231	0 445 120 255	0 445 120 004	0 445 120 014	0 445 120 032	0 445 120 113
0 445 120 036	0 445 120 70	0 445 120 122	0 445 120 173	0 445 120 238	0 445 120 256	0 445 120 005	0 445 120 015	0 445 120 043	0 445 120 114
0 445 120 037	0 445 120 094	0 445 120 123	0 445 120 174	0 445 120 239	0 445 120 272	0 445 120 006	0 445 120 016	0 445 120 046	-
0 445 120 038	0 445 120 096	0 445 120 125	0 445 120 175	0 445 120 240	0 445 120 273	0 445 120 007	0 445 120 017	0 445 120 069	-
0 445 120 039	0 445 120 097	0 445 120 132	0 445 120 176	0 445 120 241	0 445 120 300	0 445 120 008	0 445 120 018	0 445 120 077	-

16 TOP DO INJETOR MWM P/ MEDIR O CURSO DA AGULHA DO BICO (DNH)



CÓD. ROBIEL	REFERÊNCIA	ESPESSURA(mm)
305.20.830	F 00V C12 408	8,30
305.20.831	F 00V C12 412	8,31
305.20.832	F 00V C12 416	8,32
305.20.833	F 00V C12 420	8,33
305.20.834	-	8,34
305.20.835	F 00V C12 424	8,35
305.20.836	F 00V C12 428	8,36
305.20.837	F 00V C12 432	8,37
305.20.838	F 00V C12 436	8,38
305.20.839	-	8,39
305.20.840	F 00V C12 440	8,40
305.20.841	F 00V C12 444	8,41
305.20.842	F 00V C12 448	8,42
305.20.843	F 00V C12 452	8,43
305.20.844	F 00V C12 456	8,44
305.20.845	F 00V C12 460	8,45
305.20.846	-	8,46
305.20.847	F 00V C12 464	8,47
305.20.848	F 00V C12 468	8,48
305.20.849	F 00V C12 472	8,49

EMBALAGEM COM 04 PEÇAS

16 TOP INJETOR CUMMINS | DUCATO P/ MEDIR O CURSO DA AGULHA DO BICO (DNH)



CÓD. ROBIEL	REFERÊNCIA	ESPESSURA(mm)
305.30.834	F 00V C12 322	8,34
305.30.835	F 00V C12 324	8,35
305.30.836	F 00V C12 328	8,36
305.30.837	F 00V C12 332	8,37
305.30.838	F 00V C12 334	8,38
305.30.839	F 00V C12 338	8,39
305.30.840	F 00V C12 340	8,40
305.30.841	F 00V C12 344	8,41
305.30.842	F 00V C12 348	8,42
305.30.843	F 00V C12 352	8,43
305.30.844	F 00V C12 354	8,44
305.30.845	F 00V C12 358	8,45
305.30.846	F 00V C12 362	8,46
305.30.847	F 00V C12 364	8,47
305.30.848	F 00V C12 368	8,48
305.30.849	F 00V C12 372	8,49
305.30.850	F 00V C12 374	8,50
305.30.851	F 00V C12 378	8,51
305.30.852	F 00V C12 382	8,52
305.30.853	F 00V C12 384	8,53
305.30.854	F 00V C12 388	8,54
305.30.855	F 00V C12 392	8,55

EMBALAGEM COM 04 PEÇAS

15
CALÇO DA DISTÂNCIA ENTRE BOBINA E INDUZIDO (RLS)

Ø Interno: 19,00 Ø Externo: 24,00



CÓD. ROBIEL	REFERÊNCIA	ESPESSURA(mm)
819.24.092	-	0,92
819.24.093	-	0,93
819.24.094	-	0,94
819.24.095	-	0,95
819.24.096	-	0,96
819.24.097	-	0,97
819.24.098	-	0,98
819.24.099	-	0,99
819.24.100	-	1,00
819.24.101	-	1,01
819.24.102	-	1,02
819.24.103	-	1,03
819.24.104	-	1,04
819.24.106	-	1,06
819.24.108	-	1,08
819.24.110	-	1,10
819.24.112	-	1,12
819.24.114	-	1,14
819.24.116	-	1,16
819.24.125	F 00R J00 128	1,25
819.24.126	F 00R J00 130	1,26
819.24.127	F 00R J00 132	1,27
819.24.128	F 00R J00 134	1,28
819.24.129	F 00R J00 136	1,29
819.24.130	F 00R J00 138	1,30
819.24.131	F 00R J00 140	1,31
819.24.132	F 00R J00 142	1,32
819.24.133	F 00R J00 144	1,33
819.24.134	F 00R J00 146	1,34
819.24.135	F 00R J00 148	1,35
819.24.140	-	1,40
819.24.145	-	1,45
819.24.150	-	1,50
819.24.155	-	1,55
819.24.160	-	1,60

EMBALAGEM COM 04 PEÇAS

14
CALÇO DO CURSO DO INDUZIDO (AH)

Ø Interno: 18,00 Ø Externo: 24,00



CÓD. ROBIEL	REFERÊNCIA	ESPESSURA(mm)
818.24.085	-	0,85
818.24.088	-	0,88
818.24.092	-	0,92
818.24.093	-	0,93
818.24.094	-	0,94
818.24.095	F 00R J00 024	0,95
818.24.096	-	0,96
818.24.097	F 00R J00 034	0,97
818.24.098	-	0,98
818.24.099	F 00R J00 044	0,99
818.24.100	-	1,00
818.24.101	F 00R J00 054	1,01
818.24.102	-	1,02
818.24.103	F 00R J00 064	1,03
818.24.105	F 00R J00 074	1,05
818.24.107	F 00R J00 084	1,07
818.24.109	F 00R J00 094	1,09

EMBALAGEM COM 04 PEÇAS

415.00.011 KIT DE CALÇOS PARA REPARAÇÃO DE INJETORES CRI | CRIN

Nº	CÓDIGOS	DESCRIÇÃO	ESPESSURAS(mm)	Peças por Medida
DNH	305.20.830 - 305.20.849	Top do Injetor MWM	8,30 à 8,49	12 peças
DNH	305.30.834 - 305.30.855	Top do Injetor Cummins Ducato	8,34 à 8,55	12 peças
-	800.02.100 - 800.02.125	Calço Restritor do Bico Common Rail	1,00 à 1,25	12 peças
MFK	802.04.10 - 802.04.125	Calço da Pré-Injeção MWM Cummins	1,00 à 1,25	12 peças
DFK	803.05.12 - 803.05.19	Calço do Bico Injetor CR Piezo	1,20 à 1,90	12 peças
-	803.06.140 - 803.06.160	Calço da Bobina do Injetor CR Iveco	1,40 à 1,60	12 peças
-	810.16.117 - 810.16.127	Calço de Pressão Common Rail Sprinter	1,17 à 1,27	12 peças
AH	818.24.092 - 818.24.103	Calço do Regulador Common Rail CP3	0,92 à 1,03	12 peças
RLS	819.24.125 - 819.24.135	Calço do Regulador Common Rail CP3	1,25 à 1,35	12 peças
-	819.25.094 - 819.25.110	Calço do Ajuste de Débito CR	0,94 à 1,10	12 peças

TOTAL DE 1740 PEÇAS

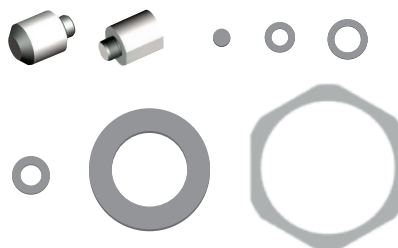

323.01.3241
Morsa Giratória para Bancada com Pino Trava



324.15.01
Suporte de Montagem e Desmontagem de Injetores



323.02.121
Escova para Limpeza e Remoção de Resíduos Ø 12,00mm



323.50.072
Kit de Ferramentas para Reparação de Injetores Bosch CRI 1.0 / 2.0 / 2.2 CRIN 1 / 1.16



323.02.29
Ferramenta de Teste da Válvula Bastão Common Rail



UTILIZE A CÂMERA DO SEU CELULAR PARA ESCANEAR O QR CODE E OBTER MAIS INFORMAÇÕES TÉCNICAS DOS PRODUTOS EM NOSSO APLICATIVO **ROBIEL**

BAIXE NOSSO NOVO APP



INJETORES CRIN 2

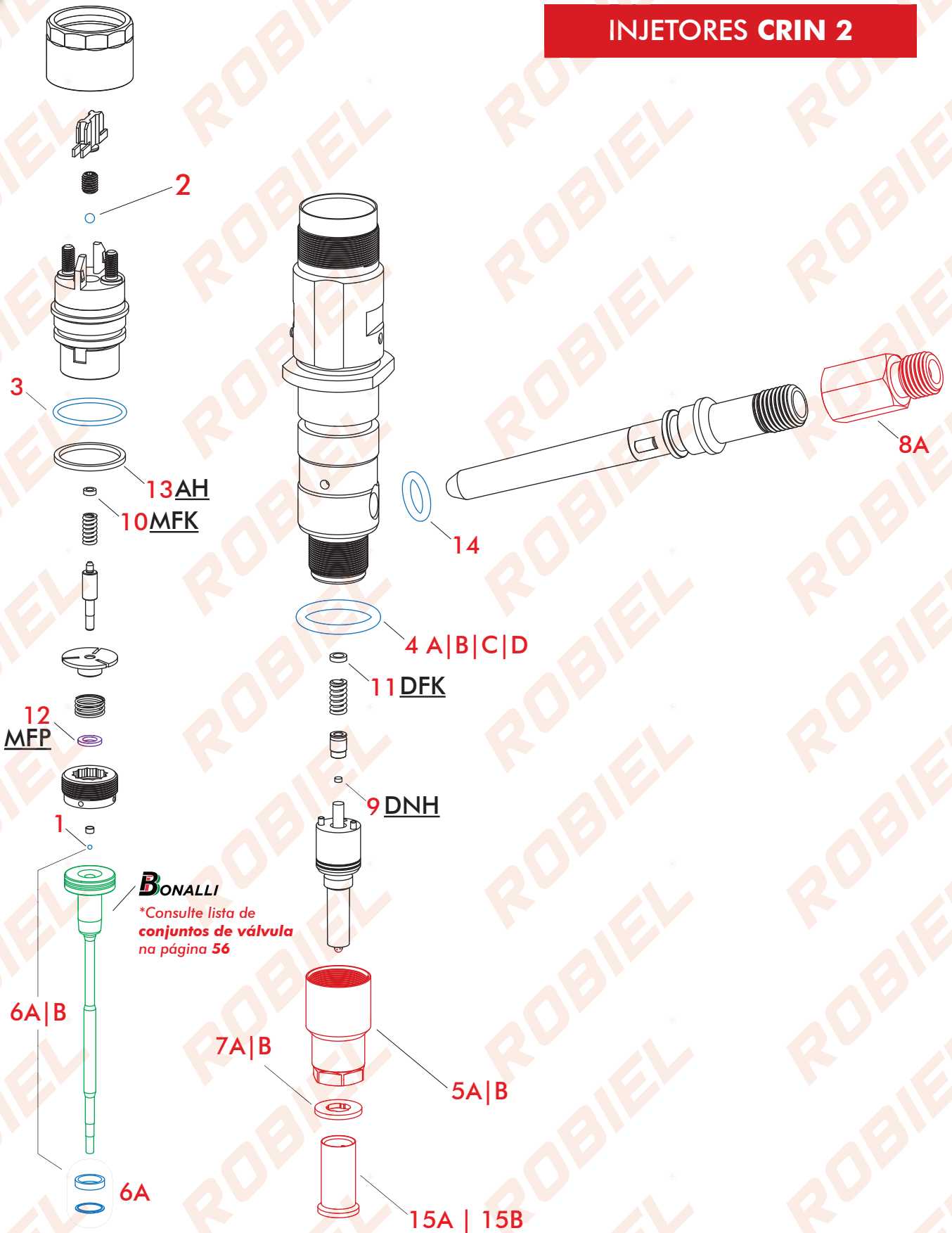

UTILIZE A CÂMERA DO SEU CELULAR PARA ESCANEAR O QR CODE E OBTER MAIS INFORMAÇÕES TÉCNICAS DOS PRODUTOS EM NOSSO APLICATIVO **ROBIEL**

BAIXE NOSSO NOVO APP

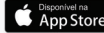

INJETOR VOLVO CRIN 2 EURO V

INJETORES

0 445 120 067

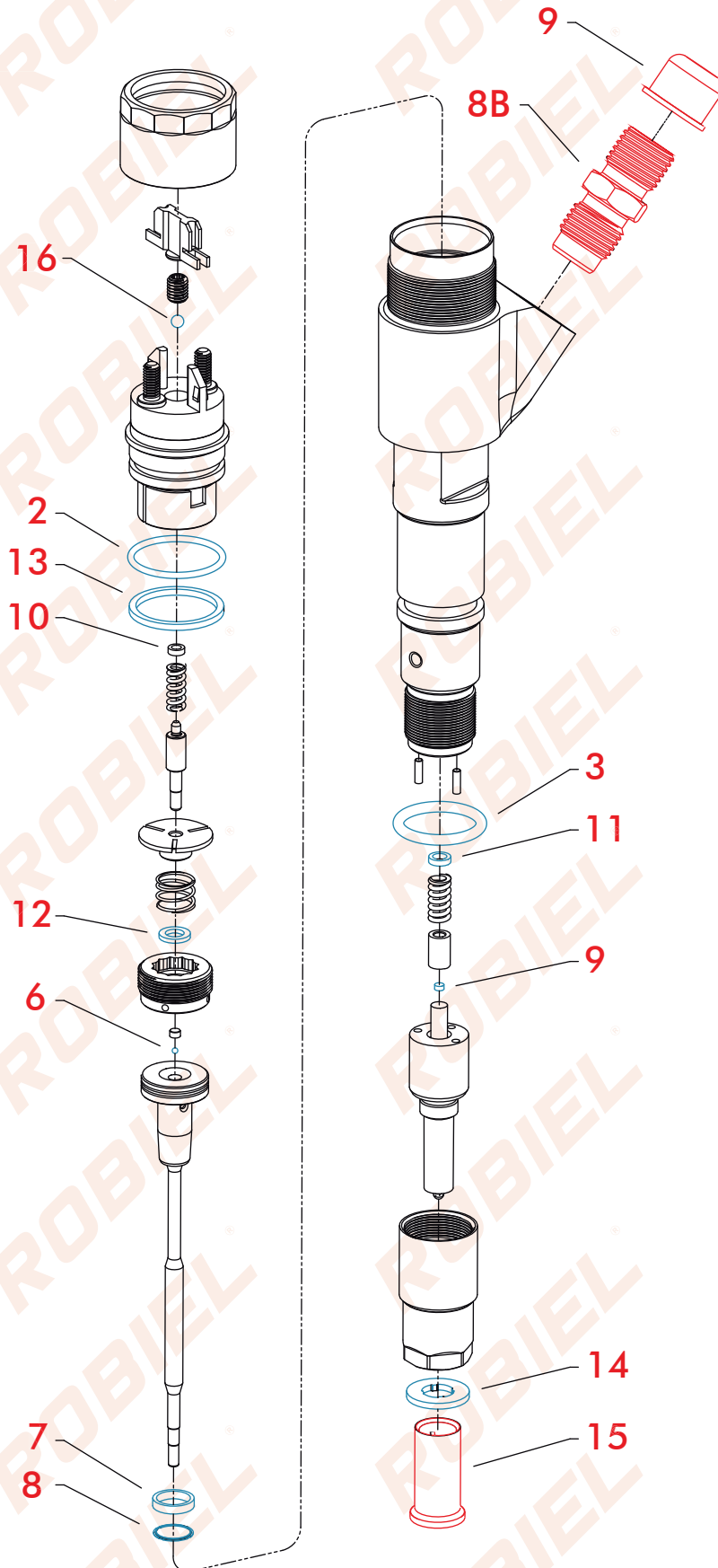

UTILIZE A CÂMERA DO SEU CELULAR PARA ESCANEAR O QR CODE E OBTER MAIS INFORMAÇÕES TÉCNICAS DOS PRODUTOS EM NOSSO APLICATIVO **ROBIEL**

BAIXE NOSSO NOVO APP



INJETORES CRIN3

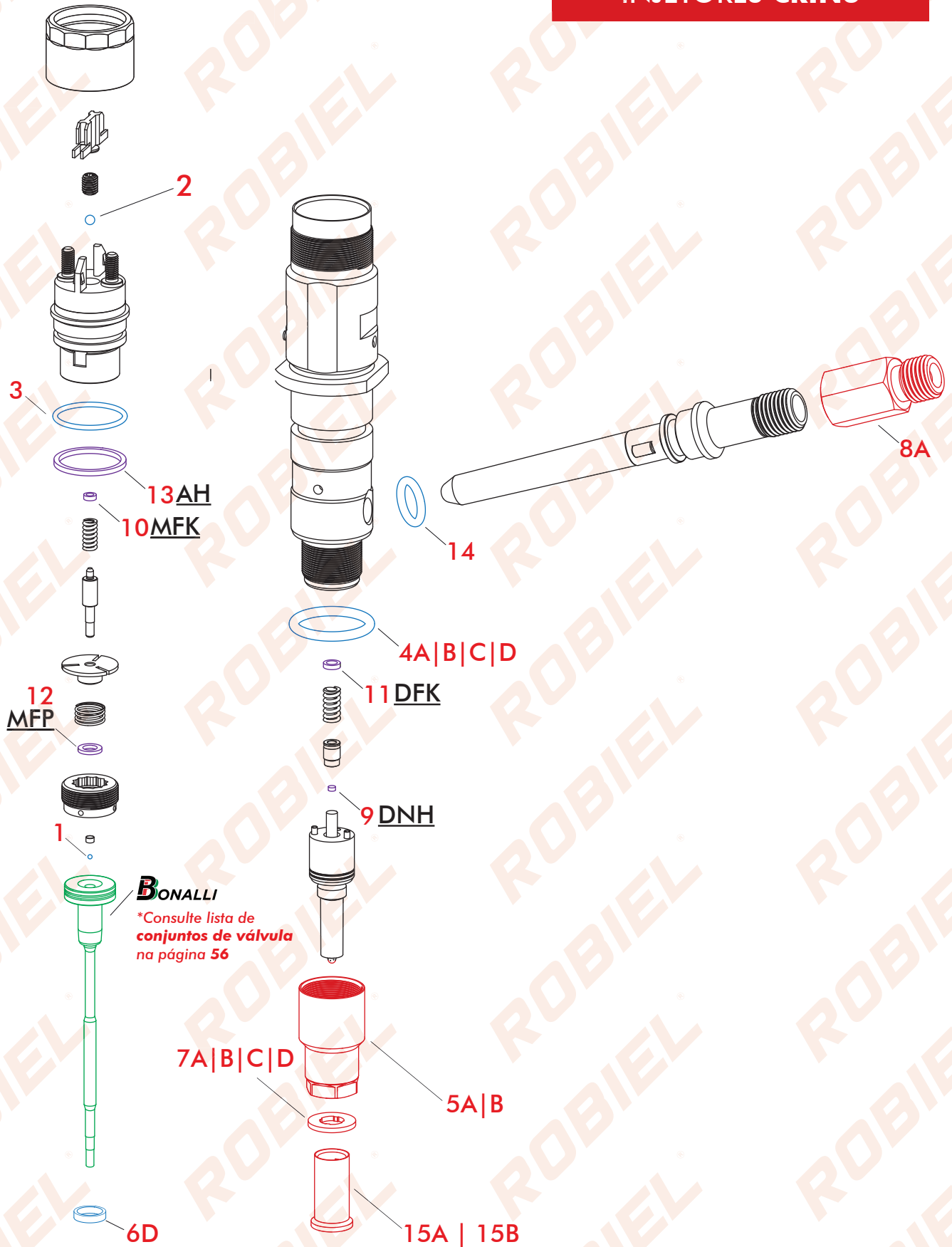



410.00.37
REPARO DO INJETOR COMMON RAIL CRIN 2 EURO 5



APLICAÇÃO		CUMMINS		
Nº	CÓD. ROBIEL	REFERÊNCIA	DESCRIÇÃO	EMB.
1	190.50.11	F 00V C05 001	Esfera Ø 1,35mm	01pç.
2	190.50.16	F 00R C00 556	Esfera Ø 3,00mm	01pç.
3	421.02.015	F 00R J00 222	Anel	01pç.
4B	421.02.130	2 430 210 081	Anel	01pç.
14	421.01.130	2 430 210 082	Anel	01pç.
6A	424.08.10C	F 00V C99 002 F 00R J02 176	Anel	01jg.
7A	600.02.07	F 00V C17 503 F 00R 501 453	Arruela 7,0 X 15,0 X 1,5	01pç.



410.00.38
REPARO DO INJETOR COMMON RAIL CRIN 3 EURO 5



APLICAÇÃO		CUMMINS		
Nº	CÓD. ROBIEL	REFERÊNCIA	DESCRIÇÃO	EMB.
1	190.50.11	F 00V C05 001	Esfera	01pç.
2	190.50.16	F 00R C00 556	Esfera	01pç.
6D	424.07.917	F 00R J02 177	Anel	01pç.
4B	421.02.130	2 430 210 081	Anel	01pç.
14	421.01.130	2 430 210 082	Anel	01pç.
3	421.02.015	F 00R J00 222	Anel	01pç.
7A	600.02.07	F 00V C17 503 F 00R 501 453	Arruela 7,0 X 15,0 X 1,5	01pç.



410.00.39
REPARO DO INJETOR COMMON RAIL CRIN 3 EURO 5

APLICAÇÃO		MWM		
Nº	CÓD. ROBIEL	REFERÊNCIA	DESCRIÇÃO	EMB.
1	190.50.11	F 00V C05 001	Esfera	01pç.
2	190.50.16	F 00R C00 556	Esfera	01pç.
3	421.02.015	F 00R J00 222	Anel	01pç.
6D	424.07.917	F 00R J02 177	Anel	01pç.
4C	421.01.720	-	Anel	01pç.
7B	600.02.08	F 00V C17 505 F 00R J01 086	Arruela 7,0 X 15,0 X 2,0	01pç.

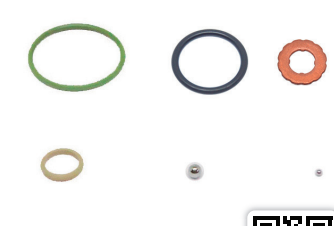

410.00.40
REPARO DO INJETOR MAN COMMON RAIL CRIN 3

INJETORES		0 445 120 162 0 445 120 186		
Nº	CÓD. ROBIEL	REFERÊNCIA	DESCRIÇÃO	EMB.
1	190.50.11	F 00V C05 001	Esfera	01pç.
2	190.50.16	F 00R C00 556	Esfera	01pç.
3	421.02.015	F 00R J00 222	Anel	01pç.
4D	421.02.430	F 00R J00 534	Anel	01pç.
6D	424.07.917	F 00R J02 177	Anel	01pç.
7D	600.02.10	F 00R J02 175	Arruela	01pç.

410.00.41**REPARO DO INJETOR MAN COMMON RAIL CRIN 2**

INJETORES

0 445 120 044 | 0 445 120 045 | 0 445 120 055

Nº	CÓD. ROBIEL	REFERÊNCIA	DESCRIÇÃO	EMB.
1	190.50.11	F 00V C05 001	Esfera	01pç.
2	190.50.16	F 00R C00 556	Esfera	01pç.
3	421.02.015	F 00R J00 222	Anel	01pç.
4D	421.02.430	F 00R J00 534	Anel	01pç.
6A	424.08.10C	F 00V C99 002 F 00R J02 176	Reparo do Bastão	01pç.
7D	600.02.10	F 00R J02 175	Arruela	01pç.

**410.20.092****REPARO DO INJETOR COMMON RAIL CRIN 2|3**

APLICAÇÃO

IVECO | CASE NH

Nº	CÓD. ROBIEL	REFERÊNCIA	DESCRIÇÃO	EMB.
1	190.50.11	F 00V C05 001	Esfera Ø 1,35mm	01pç.
2	190.50.16	F 00R C00 556	Esfera Ø 3,00mm	01pç.
3	421.02.015	F 00R J00 222	Anel	01pç.
4A	421.02.835	-	Anel	01pç.

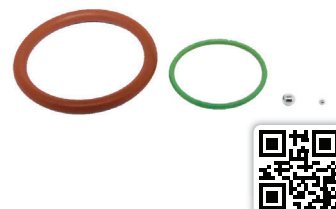
**410.08.067****REPARO INJETOR VOLVO RENAULT - COMPLETO**

CÓD. REFERÊNCIA

Nº	CÓD. ROBIEL	REFERÊNCIA	DESCRIÇÃO	EMB.
2	421.02.0150	F00RJ00222	Anel Oring Verde 20,00 x 1,50mm	01pç.
6	190.50.11	F00VC05001	Esfera Diâmetro 1,34mm	01pç.
7	424.08.10	F00RJ02176	Anel Perfil Marrom 8,00 x 1,60mm	01pç.
8	808.10.010	F00RJ02176	Calço Bastão Bico Common Rail	01pç.
9	220.03.02	-	Tampa de Proteção B - Rosca 14,0mm	01pç.
11	421.01.725	F00RJ01482	Anel Oring Verde	01pç.
14	600.02.07	F00RJ01453	Arruela Perfil de Cobre 7,0mm x 15,0mm x 1,50mm	01pç.
15	220.03.08	F00RJ04364	Tampa Protetora P/ Bico Injetor 7,00mm	01pç.



PEÇAS AVULSAS

Nº	CÓD. ROBIEL	REFERÊNCIA	DESCRIÇÃO	EMB.
1	190.50.11	F 00V C05 001	Esfera do Injetor Common Rail Ø 1,35mm	12pç.
5A	315.06.56	F 00R J00 713 F 00R J02 219	Porca do Bico Injetor CRIN 3 Euro 5	04pç.
5B	315.06.57	F 00R J00 842	Porca do Bico Injetor 0 445 120 092 157 279 002	01pç.
6A	424.08.10C	F 00V C99 002 F 00R J02 176	Reparo do Bastão	04jg.
6B	424.08.10D	F 00V C99 002 + Esfera	Reparo do Bastão com Esfera Ø1,34mm	01jg.
6C	424.08.10E	F 00V C99 002 + Esfera	Reparo do Bastão com Esfera Ø1,50mm	01jg.
6D	424.07.917	F00R J02 177	Anel Bastão do Injetor CRIN 3	06pç.
7A	600.02.07	F 00V C17 503 F 00R J01 453	Arruela 7,0 X 15,0 X 1,5	24pç.
7B	600.02.08	F 00V C17 505 F 00R J01 086	Arruela 7,0 X 15,0 X 2,0	24pç.
7C	600.07.17	CASE 504 262 598	Arruela Cônica do Injetor CASE MAGNUN MX235	12pç.
7D	600.02.10	F 00R J02 175	Arruela do bico injetor Man	06pç.
8A	165.02.15	Injetores c/ Caneta	Conexão com Microfiltro CR Delphi Bosch M14x1,50mm	01pç.
8B	165.02.16	Injetores s/ Caneta	Conexão com Microfiltro Injetores CR MWM M14x1,50mm	01pç.
15A	220.03.08	F 00R J02 537 F 00R J03 561 6.000.900.262	Capa Protetora do Bico Injetor Ø 7,00mm	01ct.
15B	220.03.09	F 00H 410 849 F 002 C88 080 6.000.900.076	Capa Protetora do Bico Injetor Ø 9,00mm	01ct.
16	190.50.16	-	Esfera do Injetor Common Rail Ø 3,00mm	01pç.
R1	421.02.430	F 00R J00 534	Anel Externo Injetor Man	06pç.

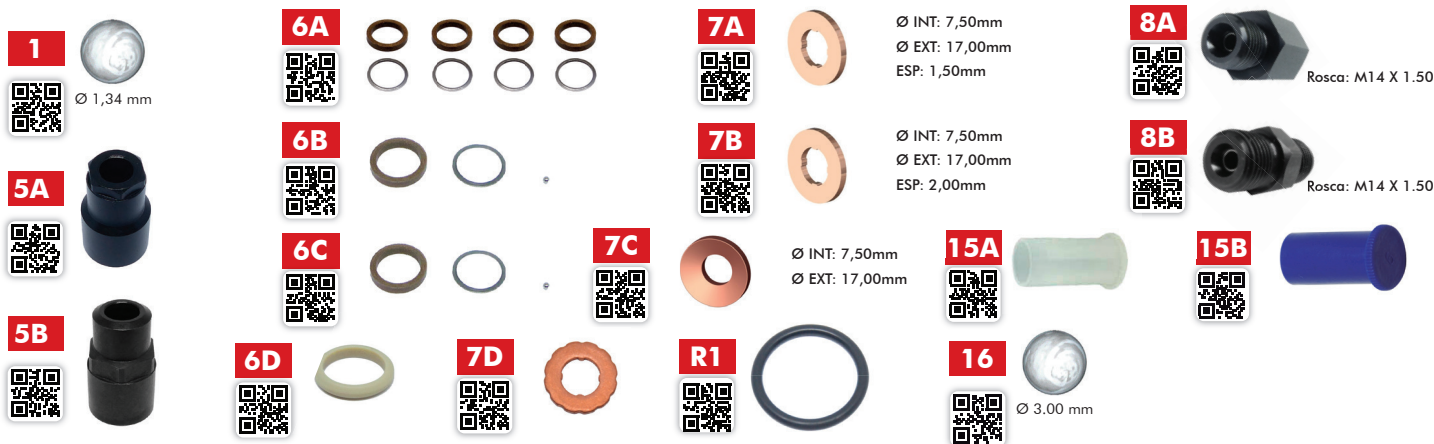

10 CALÇO DA FORÇA DA MOLA DA BOBINA (MFK)					
Ø Interno: 2,25 Ø Externo: 4,00					
CÓD. ROBIEL	REFERÊNCIA	ESPESSURA(mm)	CÓD. ROBIEL	REFERÊNCIA	ESPESSURA(mm)
802.04.10	F 00R J04 649	1,00	802.04.14	F 00R J04 662	1,40
802.04.105	F 00R J04 651	1,05	802.04.145	F 00R J04 664	1,45
802.04.11	F 00R J04 652	1,10	802.04.15	F 00R J04 666	1,50
802.04.115	F 00R J04 654	1,15	802.04.155	F 00R J04 667	1,55
802.04.12	F 00R J04 656	1,20	802.04.16	F 00R J04 669	1,60
802.04.125	F 00R J04 657	1,25	802.04.165	-	1,65
802.04.13	F 00R J04 659	1,30	802.04.17	-	1,70
802.04.135	F 00R J04 661	1,35	EMBALAGEM COM 06 PEÇAS		

9	CALÇO DO AJUSTE DO CURSO DA AGULHA DO BICO (DNH)		
	Ø Externo: 2,30		
	CÓD. ROBIEL	REFERÊNCIA	ESPESSURA(mm)
●	800.02.100	-	1,00
	800.02.101	-	1,01
	800.02.102	-	1,02
	800.02.103	-	1,03
	800.02.104	-	1,04
	800.02.105	-	1,05
	800.02.106	-	1,06
	800.02.107	-	1,07
	800.02.108	-	1,08
	800.02.109	-	1,09
	800.02.110	F 00V C12 540	1,10
	800.02.111	-	1,11
	800.02.112	-	1,12
	800.02.113	F 00V C12 526	1,13
	800.02.114	-	1,14
	800.02.115	F 00V C12 530	1,15
	800.02.116	-	1,16
	800.02.117	-	1,17
	800.02.118	F 00V C12 536	1,18
	800.02.119	-	1,19
	800.02.120	F 00V C12 540	1,20
	800.02.121	-	1,21
	800.02.122	-	1,22
	800.02.123	F 00V C12 546	1,23
	800.02.124	-	1,24
	800.02.125	F 00V C12 550	1,25
	800.02.126	-	1,26
	800.02.127	-	1,27
	800.02.128	-	1,28
	800.02.129	-	1,29
	800.02.130	-	1,30
	800.02.131	-	1,31
	800.02.132	-	1,32
	800.02.133	-	1,33
	800.02.134	-	1,34
	800.02.135	-	1,35
	800.02.138	-	1,38
	800.02.140	-	1,40
EMBALAGEM COM 06 PEÇAS			

11	CALÇO DA FORÇA DA MOLA DO BICO (DFK)		
	Ø Interno: 3,50 Ø Externo: 5,30		
	CÓD. ROBIEL	REFERÊNCIA	ESPESSURA(mm)
○	803.05.07	-	0,70
	803.05.075	-	0,75
	803.05.08	-	0,80
	803.05.085	-	0,85
	803.05.09	-	0,90
	803.05.095	-	0,95
	803.05.10	F 00V C10 460	1,00
	803.05.105	F 00V C10 464	1,05
	803.05.11	F 00V C10 470	1,10
	803.05.115	F 00V C10 474	1,15
	803.05.12	F 00V C10 480	1,20
	803.05.125	F 00V C10 484	1,25
	803.05.13	F 00V C10 490	1,30
	803.05.135	F 00V C10 494	1,35
	803.05.14	F 00V C10 500	1,40
	803.05.145	F 00V C10 504	1,45
	803.05.15	F 00V C10 510	1,50
	803.05.155	F 00V C10 514	1,55
	803.05.16	F 00V C10 520	1,60
	803.05.165	F 00V C10 524	1,65
	803.05.17	F 00V C10 530	1,70
	803.05.175	F 00V C10 534	1,75
	803.05.18	F 00V C10 540	1,80
	803.05.19	F 00V C10 550	1,90
	803.05.20	F 00V C10 560	2,00
EMBALAGEM COM 06 PEÇAS			

12	CALÇO DO MOVIMENTO DA PLACA FLUTUANTE (MFP)		
	Ø Interno: 4,50 Ø Externo: 7,70		
	CÓD. ROBIEL	REFERÊNCIA	ESPESSURA(mm)
○	805.07.100	F 00R J01 009	1,00
	805.07.101	-	1,01
	805.07.102	-	1,02
	805.07.103	-	1,03
	805.07.104	F 00R J01 010	1,04
	805.07.105	-	1,05
	805.07.106	-	1,06
	805.07.107	-	1,07
	805.07.108	F 00R J01 018	1,08
	805.07.109	-	1,09
	805.07.110	F 00R J01 020	1,10
	805.07.111	-	1,11
	805.07.112	F 00R J01 022	1,12
EMBALAGEM COM 06 PEÇAS			

* Aplicação em injetores: 0 445 120 092 e 0 445 120 157
Veículos: Iveco | Case New Holland

13

CALÇO DO CURSO DO INDUZIDO (AH)

Ø Interno: 19,60 Ø Externo: 22,80

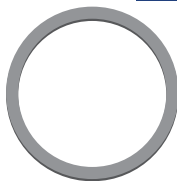

CÓD. ROBIEL	REFERÊNCIA	ESPESSURA(mm)	CÓD. ROBIEL	REFERÊNCIA	ESPESSURA(mm)
819.22.150	-	1,50	819.22.161	F00RJ04695/696	1,61
819.22.151	F00RJ04670/671	1,51	819.22.162	F00RJ04697/698	1,62
819.22.152	F00RJ04672/673	1,52	819.22.163	F00RJ04700/701	1,63
819.22.153	F00RJ04675/676	1,53	819.22.164	F00RJ06702/703	1,64
819.22.154	F00RJ100883/677	1,54	819.22.166	F00RJ04707/708	1,66
819.22.155	F00RJ04679/80	1,55	819.22.168	F00RJ04712/713	1,68
819.22.156	F00RJ00893 F00RJ0682/683	1,56	819.22.170	-	1,70
819.22.157	F00RJ004685/686	1,57	EMBALAGEM COM 06 PEÇAS		
819.22.158	F00RJ00903 F00RJ04687/688	1,58			
819.22.159	F00RJ04690/691	1,59	EMBALAGEM COM 06 PEÇAS		
819.22.160	F00RJ00913 F00RJ04692/693	1,60			

* Aplicação em injetores: 0 445 120 092 e 0 445 120 157
Veículos: Iveco | Case New Holland

TABELA DE INJETORES

CRIN 2	CRIN 2	CRIN 2	CRIN 2	CRIN 2	CRIN 2	CRIN 3	CRIN 3	CRIN 3	CRIN 3.3
0 445 120 024	0 445 120 078	0 445 120 130	0 445 120 164	0 445 120 222	0 445 120 264	0 445 120 050	0 445 120 184	0 445 120 257	0 445 120 058
0 445 120 026	0 445 120 080	0 445 120 131	0 445 120 165	0 445 120 223	0 445 120 265	0 445 120 071	0 445 120 185	0 445 120 258	0 445 120 095
0 445 120 030	0 445 120 081	0 445 120 134	0 445 120 166	0 445 120 224	0 445 120 266	0 445 120 092	0 445 120 186	0 445 120 259	0 445 120 109
0 445 120 044	0 445 120 083	0 445 120 136	0 445 120 169	0 445 120 225	0 445 120 268	0 445 120 118	0 445 120 187	0 445 120 267	0 445 120 243
0 445 120 045	0 445 120 086	0 445 120 137	0 445 120 170	0 445 120 226	0 445 120 274	0 445 120 135	0 445 120 188	0 445 120 269	C/ CONECTOR
0 445 120 053	0 445 120 087	0 445 120 138	0 445 120 182	0 445 120 227	0 445 120 275	0 445 120 143	0 445 120 193	0 445 120 276	0 445 120 047
0 445 120 054	0 445 120 088	0 445 120 139	0 445 120 183	0 445 120 228	0 445 120 277	0 445 120 157	0 445 120 197	0 445 120 279	0 445 120 048
0 445 120 055	0 445 120 098	0 445 120 141	0 445 120 190	0 445 120 232	0 445 120 278	0 445 120 161	0 445 120 199	0 445 120 281	0 445 120 049
0 445 120 056	0 445 120 099	0 445 120 142	0 445 120 191	0 445 120 234	0 445 120 289	0 445 120 162	0 445 120 201	0 445 120 282	0 445 120 072
0 445 120 057	0 445 120 100	0 445 120 145	0 445 120 192	0 445 120 236	0 445 120 290	0 445 120 167	0 445 120 202	0 445 120 327	0 445 120 073
0 445 120 061	0 445 120 101	0 445 120 146	0 445 120 196	0 445 120 237	0 445 120 291	0 445 120 177	0 445 120 204	C/ CONECTOR	0 445 120 076
0 445 120 062	0 445 120 102	0 445 120 147	0 445 120 200	0 445 120 242	0 445 120 292	0 445 120 178	0 445 120 216	0 445 120 042	0 445 120 090
0 445 120 063	0 445 120 105	0 445 120 148	0 445 120 203	0 445 120 244	0 445 120 293	0 445 120 179	0 445 120 229	0 445 120 082	0 445 120 091
0 445 120 064	0 445 120 106	0 445 120 149	0 445 120 213	0 445 120 245	0 445 120 294	0 445 120 180	0 445 120 233	-	0 445 120 093
0 445 120 065	0 445 120 107	0 445 120 150	0 445 120 215	0 445 120 246	0 445 120 295	0 445 120 181	0 445 120 235	-	0 445 120 126
0 445 120 066	0 445 120 110	0 445 120 153	0 445 120 217	0 445 120 247	C/ CONECTOR	-	-	-	-
0 445 120 067	0 445 120 111	0 445 120 154	0 445 120 218	0 445 120 260	0 445 120 027	-	-	-	-
0 445 120 068	0 445 120 117	0 445 120 155	0 445 120 219	0 445 120 261	-	-	-	-	-
0 445 120 074	0 445 120 124	0 445 120 156	0 445 120 220	0 445 120 262	-	-	-	-	-
0 445 120 075	0 445 120 127	0 445 120 158	0 445 120 221	0 445 120 263	-	-	-	-	-

415.00.021 KIT DE CALÇOS PARA REPARAÇÃO DE INJETORES CRIN 2 | CRIN 3

Nº	CÓDIGOS	DESCRIÇÃO	ESPESSURAS(mm)	Peças por Medida
AH	819.22.150 - 819.22.160	Calço da Bobina Injetor Iveco Case NH	1,50 à 1,60	12 peças
MFK	802.04.13 - 802.04.165	Calço da Pré-Injeção MWM Cummins	1,30 à 1,70	12 peças
MFP	805.07.100 - 805.07.112	Curso da Esfera do Solenóide Iveco	1,00 à 1,12	12 peças
DFK	803.05.12 - 803.05.16	Calço do Bico Injetor CR Piezo	1,20 à 1,60	12 peças
DNH	800.02.110 - 800.02.125	Calço Restritor do Bico Injetor CR	1,10 à 1,25	12 peças

TOTAL DE 576 PEÇAS



323.01.3241

Morsa Giratória para Bancada com Pino Trava



323.02.121

Escova para Limpeza e Remoção de Resíduos Ø 12,00mm

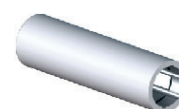

323.01.841

Chave da Porca do Bico Injetores Iveco Códigos: 0 445 120 002|092|157|276



324.15.01

Suporte de Montagem e Desmontagem de Injetores



323.02.291

Ferramenta de Teste da Válvula Bastão Common Rail Injetores CRIN 3



323.50.063

Kit de Ferramentas para Reparação de Injetores Bosch CRIN 2|3



UTILIZE A CÂMERA DO SEU CELULAR PARA ESCANEAR O QR CODE E OBTER MAIS **INFORMAÇÕES TÉCNICAS** DOS PRODUTOS EM NOSSO APLICATIVO **ROBIEL®**

BAIXE NOSSO NOVO APP

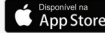

INJETOR CRIN 4.2

FREIGHTLINER | DETROIT DDE 16 15.6L
DETROIT DDE 15 14.8L | DETROIT DDE13 12.8L

INJETORES

- 0 445 120 104
- 0 445 120 194
- 0 445 120 195
- 0 445 120 207
- 0 445 120 270
- 0 445 120 271
- 0 445 120 283
- 0 445 120 284
- 0 445 120 285
- 0 445 120 286
- 0 445 120 287
- 0 445 120 288
- 0 445 120 298
- 0 445 120 299
- 0 445 120 300
- 0 445 120 301
- 0 445 120 302
- 0 445 120 303
- 0 445 120 374
- 0 445 120 375
- 0 445 120 385
- 0 445 120 386

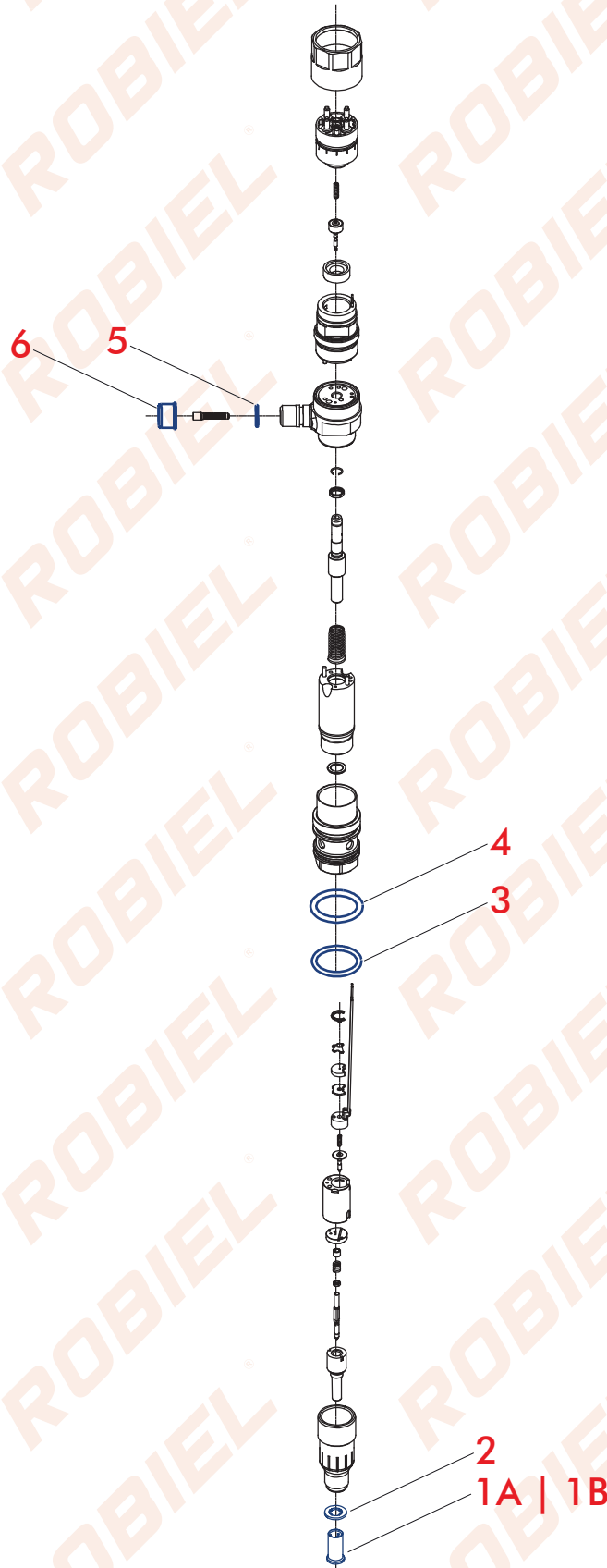

410.33.337
REPARO EXTERNO INJETOR CRIN 4.2

CÓD. REFERÊNCIA		F 00E 200 337		
Nº	CÓD. ROBIEL	REFERÊNCIA	DESCRIÇÃO	EMB.
1A	220.03.08	F 00R J02 537 F 00R J03 561 6.000.900.262	Capa Protetora	01 pç.
2	600.02.01	2 430 105 049	Arruela	01 pç.
3	421.30.265	F 00R J01 951	Anel Oring	01 pç.
4	421.29.735	F 00R J01 950	Anel Oring	01 pç.
5	421.01.320	F 00R J01 947	Anel Oring	01 pç.
6	220.03.03	-	Tampa Plástica	01 pç.



PEÇAS AVULSAS

Nº	CÓD. ROBIEL	REFERÊNCIA	DESCRIÇÃO	EMB.
1A	220.03.08	F 00R J02 537 F 00R J03 561 6.000.900.262	Capa Protetora do Bico Injetor Ø 7,00mm	01ct.
1B	220.03.09	F 00H 410 849 F 002 C88 080 6.000.900.076	Capa Protetora do Bico Injetor Ø 9,00mm	01ct.
6	220.03.03	-	Tamp Plástica - Ø Externo 17,00 x Ø Interno 15,00mm	01ct.
2	600.02.01	2 430 105 049	Arruela Perfil Cobre - 7,00 x 15,50 x 1,50mm	01ct.



UTILIZE A CÂMERA DO SEU CELULAR PARA ESCANEAR O QR CODE E OBTER MAIS INFORMAÇÕES TÉCNICAS DOS PRODUTOS EM NOSSO APLICATIVO **ROBIEL**

BAIXE NOSSO NOVO APP



INJETORES CATERPILLAR C4/C6 | PERKINS | MITSUBISHI

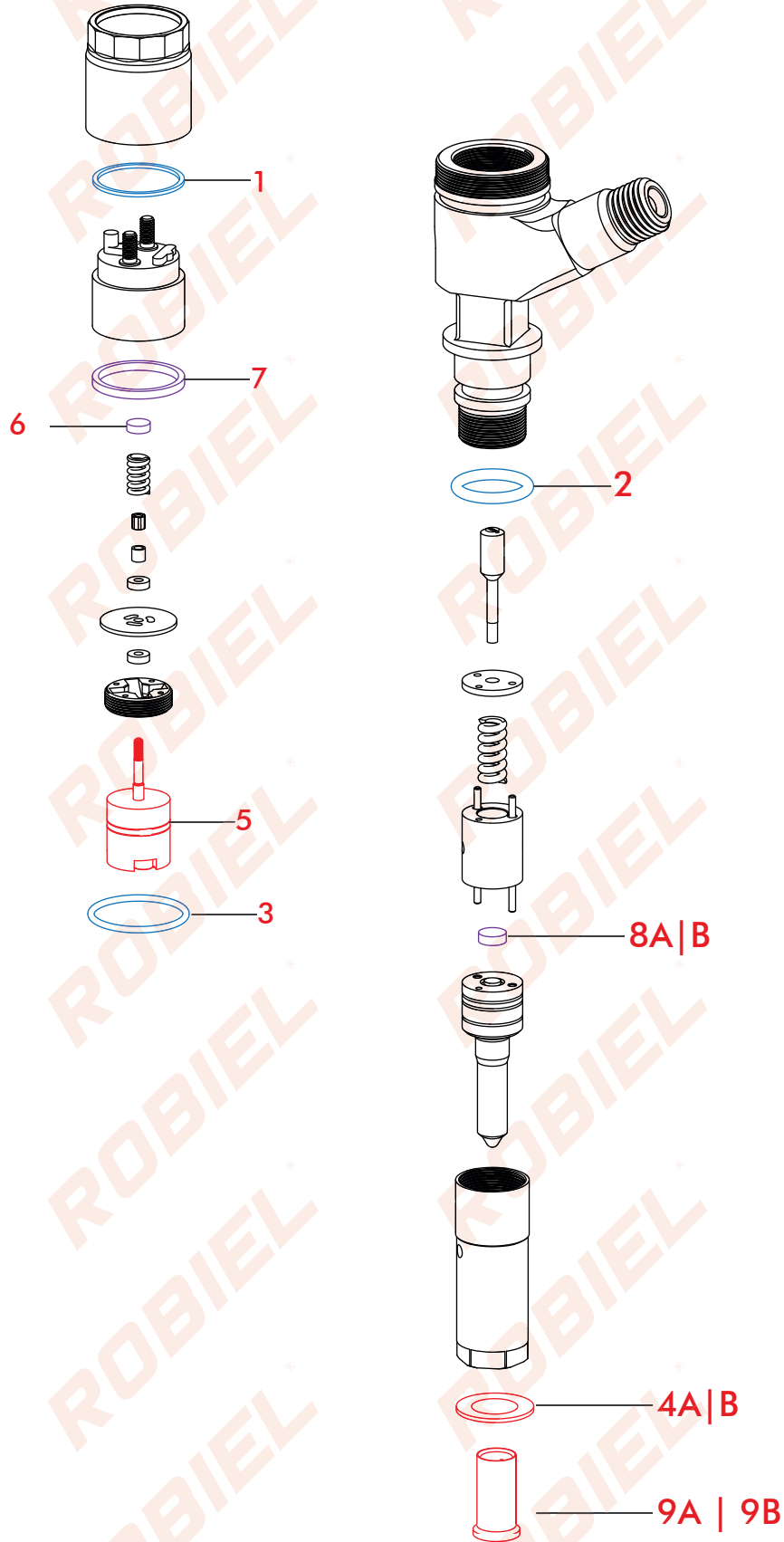

410.00.062

REPARO DO INJETOR CATERPILLAR/PERKINS

CÓD. REFERÊNCIA				
Nº	CÓD. ROBIEL	REFERÊNCIA	DESCRIÇÃO	EMB.
1	623.26.10	-	Arruela	01pç.
2	421.01.426	-	Anel	01pç.
3	421.02.417	-	Anel	01pç.



PEÇAS AVULSAS

Nº	CÓD. ROBIEL	REFERÊNCIA	DESCRIÇÃO	EMB.
4A	607.14.20	MN155904	Arruela do Bico Injetor Caterpillar 7,00 X 13,70 X 2,00	48pç.
4B	607.14.10	-	Arruela do Bico Injetor Caterpillar 7,00 X 13,70 X 1,00	48pç.
5	VC6.10.0062	32F61-00062	Válvula de Controle Caterpillar 320D	01pç.
9A	220.03.08	F 00R J02 537 F 00R J03 561 6.000.900.262	Capa Protetora do Bico Injetor Ø 7,00mm	01ct.
9B	220.03.09	F 00H 410 849 F 002 C88 080 6.000.900.076	Capa Protetora do Bico Injetor Ø 9,00mm	01ct.

4A  Espessura: 2,00 mm



4B  Espessura: 1,00 mm



5 



9A 



9B 



6 CALÇO DA BOBINA DO INJETOR CATERPILLAR

Ø Externo: 6,60mm



CÓD. ROBIEL	REFERÊNCIA	ESPESSURA(mm)
800.07.218	-	2,18
800.07.220	-	2,20
800.07.222	-	2,22
800.07.224	-	2,24
800.07.226	-	2,26
800.07.228	-	2,28
800.07.230	-	2,30
800.07.232	-	2,32

EMBALAGEM COM 8 PEÇAS

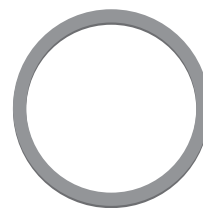

7 CALÇO DA INDUTÂNCIA DO INJETOR CATERPILLAR

22,5 x 26,0mm



CÓD. ROBIEL	REFERÊNCIA	ESPESSURA(mm)
822.26.228	-	2,28
822.26.230	-	2,30
822.26.232	-	2,32
822.26.234	-	2,34
822.26.236	-	2,36
822.26.238	-	2,38

EMBALAGEM COM 8 PEÇAS

8A	CALÇO DO BICO INJETOR CATERPILLAR AGULHA ALTA		
	INOX - Ø Externo: 6,60mm		
	CÓD. ROBIEL	REFERÊNCIA	ESPESSURA(mm)
	800.07.140	-	1,40
	800.07.142	-	1,42
	800.07.144	-	1,44
	800.07.146	-	1,46
	800.07.148	-	1,48
	800.07.150	-	1,50
	800.07.152	-	1,52
	800.07.154	-	1,54
	800.07.156	-	1,56
	800.07.158	-	1,58
	800.07.160	-	1,60
EMBALAGEM COM 8 PEÇAS			

8B	CALÇO DO BICO INJETOR CATERPILLAR AGULHA BAIXA		
	INOX - Ø Externo: 6,60mm		
	CÓD. ROBIEL	REFERÊNCIA	ESPESSURA(mm)
	800.07.206	-	2,06
	800.07.208	-	2,08
	800.07.210	-	2,10
	800.07.212	-	2,12
	800.07.214	-	2,14
	800.07.216	-	2,16
	800.07.218	-	2,18
	800.07.220	-	2,20
	800.07.222	-	2,22
	800.07.224	-	2,24
	800.07.226	-	2,26
	800.07.228	-	2,28
	800.07.230	-	2,30
	800.07.232	-	2,32
	800.07.234	-	2,34
	800.07.236	-	2,36
	800.07.238	-	2,38
EMBALAGEM COM 8 PEÇAS			

415.01.01 KIT DE CALÇOS PARA REPARAÇÃO DE INJETORES E BOMBAS CATERPILLAR C4 C6			
CÓDIGOS	DESCRIÇÃO	ESPESSURAS(mm)	Peças por Medida
800.07.140 - 800.07.230	Calço do Bico/Bobina do Injetor	1,40 à 2,30	12 peças
822.26.228 - 822.26.238	Calço da Indutância do Injetor	2,28 à 2,38	12 peças
803.07.125 - 803.07.15	Calço de Ajuste do solenoide da BBA	1,25 à 1,50	12 peças
803.09.165 - 803.09.20	Calço de Ajuste da bobina da BBA	1,65 à 2,00	12 peças
TOTAL DE 528 PEÇAS			





CONSULTE OS PRODUTOS DE
MANEIRA **RÁPIDA E PRÁTICA**



SOLICITE SEU **ORÇAMENTO**
SEM SAIR DO APP



FIQUE POR DENTRO DE
NOSSOS **LANÇAMENTOS**



ENCONTRE O PRODUTO QUE
ESTAVA PROCURANDO ATRAVÉS
DA **CÂMERA DO SEU CELULAR**



E VOCÊ, JÁ BAIXOU O
APLICATIVO **ROBIEL**?

BAIXE AGORA!

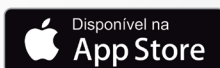

UTILIZE A CÂMERA DO SEU CELULAR PARA ESCANEAR O QR CODE E OBTER MAIS **INFORMAÇÕES TÉCNICAS** DOS PRODUTOS EM NOSSO APLICATIVO **ROBIEL**

BAIXE NOSSO NOVO APP



INJETOR CUMMINS XPI

SCANIA D9 XPI | D13 XPI | D16 XPI
DC13 XPI CUMMINS ISX 15

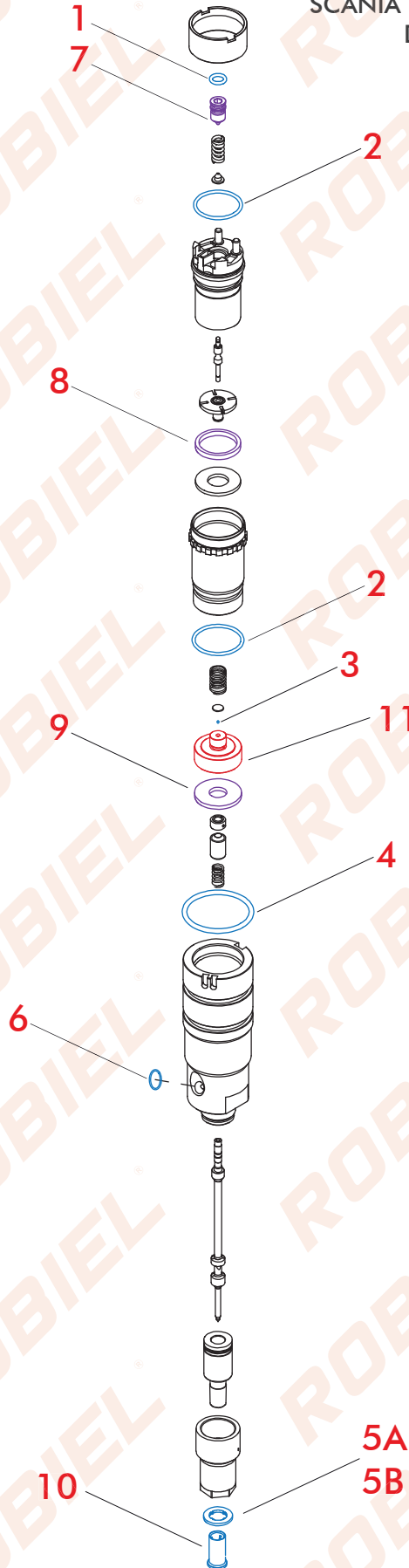

INJETORES

1881564

2031836

2086663

2872405

410.32.211 REPARO INJETOR CUMMINS ISX 15 XPI - COMPLETO				
CÓD. REFERÊNCIA		1932820 1933246		
Nº	CÓD. ROBIEL	REFERÊNCIA	DESCRIÇÃO	EMB.
1	421.06.178	-	Anel Oring	01pç.
2	421.23.518	-	Anel Oring	02pç.
3	190.52.01	-	Esfera Cerâmica	01pç.
4	421.35.626	-	Anel Oring	01pç.
5A	609.16.15	-	Arruela de Cobre	01pç.
6	421.12.262	-	Anel Oring	01pç.
10	220.03.08	F 00H 410 849 F 002 C88 080 6.000.900.076	Capa Protetora	01pç.

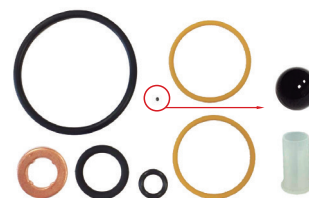

410.32.212 REPARO INJETOR CUMMINS ISX 15 XPI - COMPLETO				
CÓD. REFERÊNCIA				
Nº	CÓD. ROBIEL	REFERÊNCIA	DESCRIÇÃO	EMB.
1	421.06.178	-	Anel Oring	01pç.
2	421.23.518	-	Anel Oring	02 pç.
3	190.52.01	-	Esfera Cerâmica	01pç.
4	421.35.626	-	Anel Oring	01pç.
5B	600.03.05	-	Luva de vedação	01pç.
6	421.12.262	-	Anel Oring	01pç.

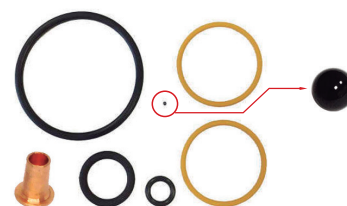

410.32.820 REPARO EXTERNO INJETOR CUMMINS ISX 15 XPI				
CÓD. REFERÊNCIA		1932820		
Nº	CÓD. ROBIEL	REFERÊNCIA	DESCRIÇÃO	EMB.
4	421.35.626	-	Anel Oring	01pç.
5	609.16.15	-	Arruela de Cobre	01pç.
6	421.12.262	-	Anel Oring	01pç.
10	220.03.08	F 00H 410 849 F 002 C88 080 6.000.900.076	Capa Protetora	01pç.



PEÇAS AVULSAS

Nº	CÓD. ROBIEL	REFERÊNCIA	DESCRIÇÃO	EMB.
11	340.16.03	-	Válvula de Controle Injetor ISX15/XPI	01 un.



7
**BUJAO INJETOR SCANIA XPI
CUMMINS ISX15 / ISL / FOTON**

CÓD. ROBIEL	REFERÊNCIA	ESPESSURA(mm)
165.07.620	-	6,20
165.07.630	-	6,30

EMBALAGEM COM 01 PEÇA
8
**CALÇO DO SOLENOIDE
XPI | ISX | ISL | FOTON**

CÓD. ROBIEL	REFERÊNCIA	ESPESSURA(mm)
821.82.290	-	2,90
821.82.292	-	2,92
821.82.294	-	2,94
821.82.296	-	2,96
821.82.298	-	2,98
821.82.300	-	3,00
821.82.302	-	3,02
821.82.304	-	3,04
821.82.306	-	3,06
821.82.308	-	3,08
821.82.310	-	3,10
821.82.312	-	3,12
821.82.314	-	3,14
821.82.316	-	3,16
821.82.318	-	3,18
821.82.320	-	3,20

EMBALAGEM COM 6 PEÇAS
9
**CALÇO DO bico
XPI | ISX**

CÓD. ROBIEL	REFERÊNCIA	ESPESSURA(mm)
810.26.210	-	2,10
810.26.212	-	2,12
810.26.214	-	2,14
810.26.216	-	2,16
810.26.218	-	2,18
810.26.220	-	2,20
810.26.222	-	2,22
810.26.224	-	2,24
810.26.226	-	2,26
810.26.228	-	2,28
810.26.230	-	2,30
810.26.232	-	2,32
810.26.234	-	2,34
810.26.236	-	2,36
810.26.238	-	2,38
810.26.240	-	2,40

EMBALAGEM COM 6 PEÇAS

323.50.38

 Kit de Reparação para
Injetores Scania | Cummins
XPI | ISX 15 | ISL | Foton

323.01.324

 Morsa Giratória para Bancada
com Pino Trava

324.15.01

 Suporte de Montagem e
Desmontagem de Injetores

APLICATIVO **ROBIEL**[®]

INÚMEROS RECURSOS PARA OTIMIZAR
A ROTINA DA SUA **OFICINA!**



ESCANEE O QR CODE PARA
REALIZAR O DOWNLOAD
DO APLICATIVO ROBIEL!

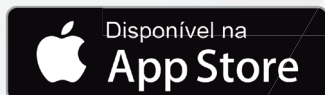

WWW.ROBIEL.COM

UTILIZE A CÂMERA DO SEU CELULAR PARA ESCANEAR O QR CODE E OBTER MAIS **INFORMAÇÕES TÉCNICAS** DOS PRODUTOS EM NOSSO APLICATIVO **ROBIEL**

BAIXE NOSSO NOVO APP



INJETOR CUMMINS ISL

SCANIA

INJETORES

2872127

4954927

4984332

4954679

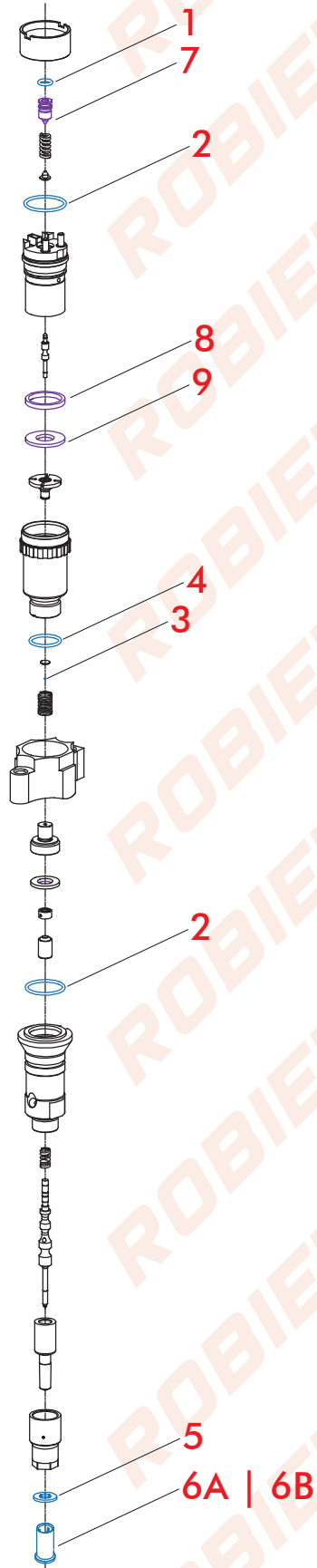

410.32.127

REPARO INJETOR CUMMINS ISC/ISL/QLS/QSC - COMPLETO

CÓD. REFERÊNCIA				
Nº	CÓD. ROBIEL	REFERÊNCIA	DESCRIÇÃO	EMB.
1	421.06.178	-	Anel Oring	01 pç.
2	421.22.178	-	Anel Oring	01 pç.
3	190.52.01	-	Esfera Cerâmica	01 pç.
4	421.01.717	-	Anel Oring	01 pç.
5	600.02.07	F 00V C17 503	Arruela de Cobre	01 pç.
6A	220.03.08	F 00R J02 537 F 00R J03 561 6.000.900.262	Tampa Protetora	01 pç.



PEÇAS AVULSAS

Nº	CÓD. ROBIEL	REFERÊNCIA	DESCRIÇÃO	EMB.
5	600.02.07	F 00V C17 503	Arruela do Porta Injetor Cummins	24 pç.
6A	220.03.08	F 00R J02 537 F 00R J03 561 6.000.900.262	Tampa Protetora para Bico Injetor Ø7,00mm	01 ct.
6B	220.03.09	F 00H 410 849 F 002 C88 080 6.000.900.076	Tampa Protetora para Bico Injetor Ø9,00mm	01 ct.



7	BUJAO INJETOR SCANIA XPI CUMMINS ISX15 / ISL / FOTON		
	CÓD. ROBIEL	REFERÊNCIA	ESPESSURA(mm)
	165.07.620	-	6,20
	165.07.630	-	6,30

EMBALAGEM COM 01 PEÇA



9	CALÇO DO BICO ISL FOTON		
	CÓD. ROBIEL	REFERÊNCIA	ESPESSURA(mm)
	818.91.0190	-	1,90
	818.91.0192	-	1,92
	818.91.0194	-	1,94
	818.91.0196	-	1,96
	818.91.0198	-	1,98
	818.91.0200	-	2,00
	818.91.0202	-	2,02
	818.91.0204	-	2,04
	818.91.0206	-	2,06
	818.91.0208	-	2,08
	818.91.0210	-	2,10
	818.91.0212	-	2,12
	818.91.0214	-	2,14
	818.91.0216	-	2,16
	818.91.0218	-	2,18
	818.91.0220	-	2,20

EMBALAGEM COM 6 PEÇAS



8	CALÇO DO SOLENOIDE XPI ISX ISL FOTON		
	CÓD. ROBIEL	REFERÊNCIA	ESPESSURA(mm)
	821.82.290	-	2,90
	821.82.292	-	2,92
	821.82.294	-	2,94
	821.82.296	-	2,96
	821.82.298	-	2,98
	821.82.300	-	3,00
	821.82.302	-	3,02
	821.82.304	-	3,04
	821.82.306	-	3,06
	821.82.308	-	3,08
	821.82.310	-	3,10
	821.82.312	-	3,12
	821.82.314	-	3,14
	821.82.316	-	3,16
	821.82.318	-	3,18
	821.82.320	-	3,20

EMBALAGEM COM 6 PEÇAS



323.50.38

Kit de Reparação para Injetores Scania | Cummins XPI | ISX 15 | ISL | Foton



UTILIZE A CÂMERA DO SEU CELULAR PARA ESCANEAR O QR CODE E OBTER MAIS INFORMAÇÕES TÉCNICAS DOS PRODUTOS EM NOSSO APLICATIVO **ROBIEL®**

BAIXE NOSSO NOVO APP



INJETOR DAF MX13

INJETORES

182-5900

213-5457

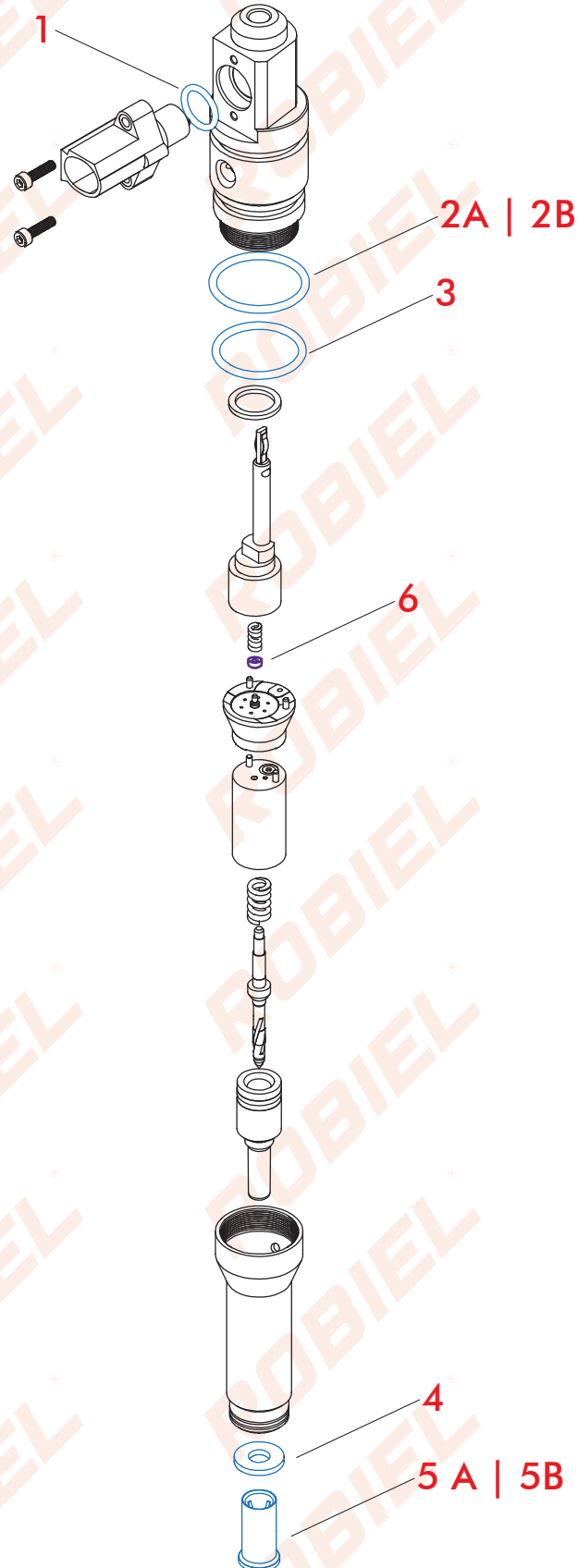

410.12.900 REPARO INJETOR DAF MX13

CÓD. REFERÊNCIA				
Nº	CÓD. ROBIEL	REFERÊNCIA	DESCRIÇÃO	EMB.
1	421.01.220	-	Anel Oring	01pç.
2A	421.27.200	182-5900	Anel Oring	01pç.
2B	421.27.250	213-5457	Anel Oring	01pç.
3	421.24.250	-	Anel Oring	01pç.
4	607.16.25	-	Arruela de Cobre	01pç.
5A	220.03.08	-	Tampa Protetora	01pç.



PEÇAS AVULSAS

Nº	CÓD. ROBIEL	REFERÊNCIA	DESCRIÇÃO	EMB.
5A	220.03.08	F 00R J02 537 F 00R J03 561 6.000.900.262	Tampa Protetora para Bico Injetor Ø7,00mm	01ct.
5B	220.03.09	F 00H 410 849 F 002 C88 080 6.000.900.076	Tampa Protetora para Bico Injetor Ø9,00mm	01ct.



6 CALÇO DA MOLA ATRACAMENTO INJETOR DAF MX13
Ø Interno: 1,90 Ø Externo: 4,40

○	CÓD. ROBIEL	REFERÊNCIA	ESPESSURA(mm)
	801.05.120	-	1,20
	801.05.125	-	1,25
	801.05.130	-	1,30
	801.05.135	-	1,35
	801.05.140	-	1,40
	801.05.145	-	1,45
	801.05.150	-	1,50
	801.05.155	-	1,55
	801.05.160	-	1,60
	801.05.165	-	1,65
	801.05.170	-	1,70

EMBALAGEM COM 12 PEÇAS

UTILIZE A CÂMERA DO SEU CELULAR PARA ESCANEAR O QR CODE E OBTER MAIS INFORMAÇÕES TÉCNICAS DOS PRODUTOS EM NOSSO APLICATIVO **ROBIEL®**

BAIXE NOSSO NOVO APP



INJETOR DELPHI

HR
H100
Sprinter
Kia Bongo

Nº INJETOR

28229873

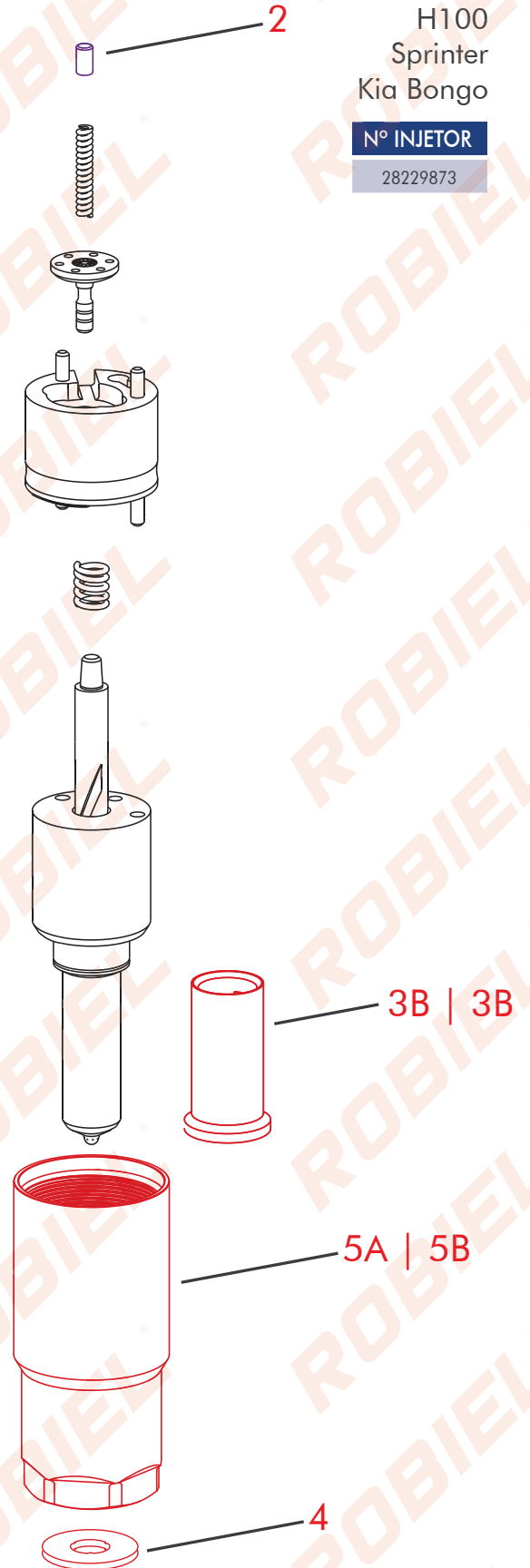
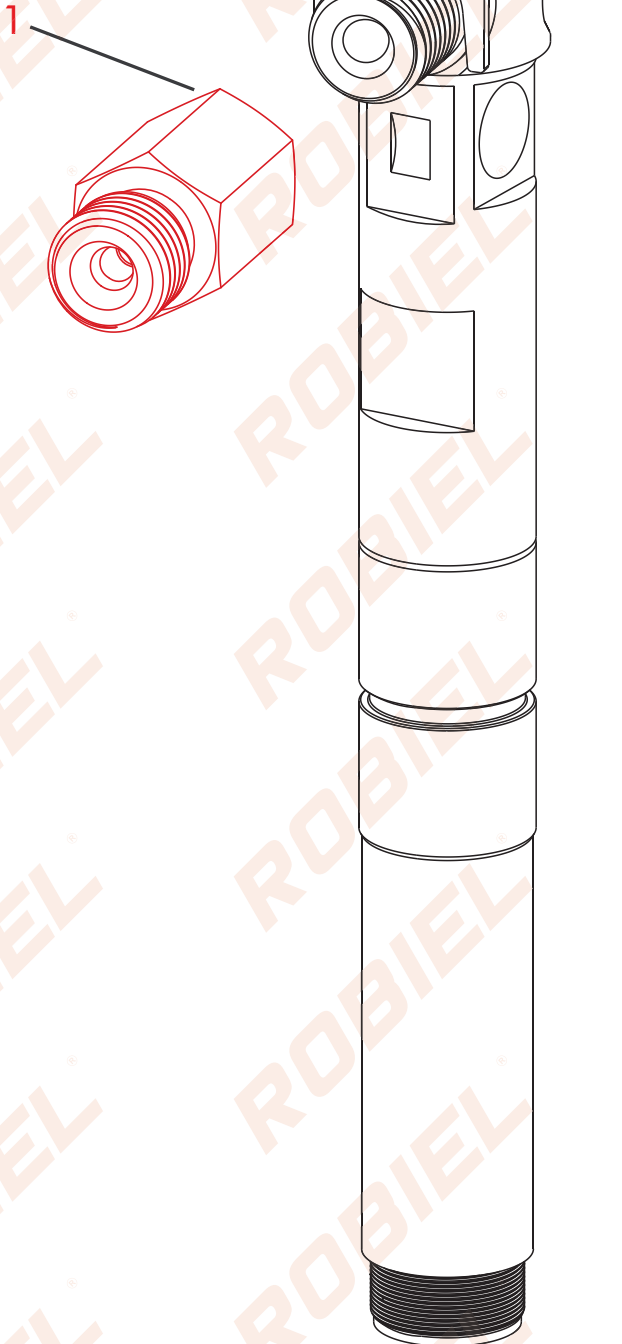

PEÇAS AVULSAS

Nº	CÓD. ROBIEL	REFERÊNCIA	DESCRIÇÃO	EMB.
1	165.02.15	Injetores c/ Caneta	Conexão com Microfiltro CR Delphi Bosch - M14x1,50mm	01pç.
3A	220.03.08	F 00R J02 537 F 00R J03 561 6.000.900.262	Capa Protetora do Bico Injetor Ø 7,00mm	01ct.
3B	220.03.09	F 00H 410 849 F 002 C88 080 6.000.900.076	Capa Protetora do Bico Injetor Ø 9,00mm	01ct.
4	607.14.20	MN155904	Arruela do Bico Injetor 7,00 X 13,70 X 2,00	48pç.
5A	315.06.59	28229873	Porca do Bico Inj. Common Rail Delphi - Kia Bongo / HR	01pç.
5B	315.06.63	-	Porca do Bico Inje. Delphi - MBB Sprinter	04pç.

1



Rosca: M14 X 1,50mm
Aplicada em Injetores
com Caneta/Bastão

3A



3B



4



Esperrura: 2,00 mm

5A



5B



2 CALÇO DE REGULAGEM DE DEBITO DO INJETOR DELPHI
Ø Externo: 2,00

CÓD. ROBIEL	APLICAÇÃO	ESPESSURA(mm)
800.20.5260	HR SPRINTER	2,60
800.20.5265	HR SPRINTER	2,65
800.20.5270	HR SPRINTER	2,70
800.20.5275	HR SPRINTER	2,75
800.20.5280	HR SPRINTER	2,80
800.20.5285	HR SPRINTER	2,85
800.20.5290	HR SPRINTER	2,90
800.20.5295	HR SPRINTER	2,95
800.20.5300	HR SPRINTER	3,00
800.20.5365	HR SPRINTER	3,65
800.20.5370	HR SPRINTER	3,70
800.20.5375	HR SPRINTER	2,75
800.20.5380	HR SPRINTER	3,80
800.20.5385	HR SPRINTER	3,85
800.20.5390	HR SPRINTER	3,90
800.20.5395	HR SPRINTER	3,95
800.20.5400	HR SPRINTER	4,00

EMBALAGEM COM 06 PEÇAS

UTILIZE A CÂMERA DO SEU CELULAR PARA ESCANEAR O QR CODE E OBTER MAIS INFORMAÇÕES TÉCNICAS DOS PRODUTOS EM NOSSO APLICATIVO **ROBIEL**

BAIXE NOSSO NOVO APP



INJETOR DELPHI

JCB
Ssangyong Action

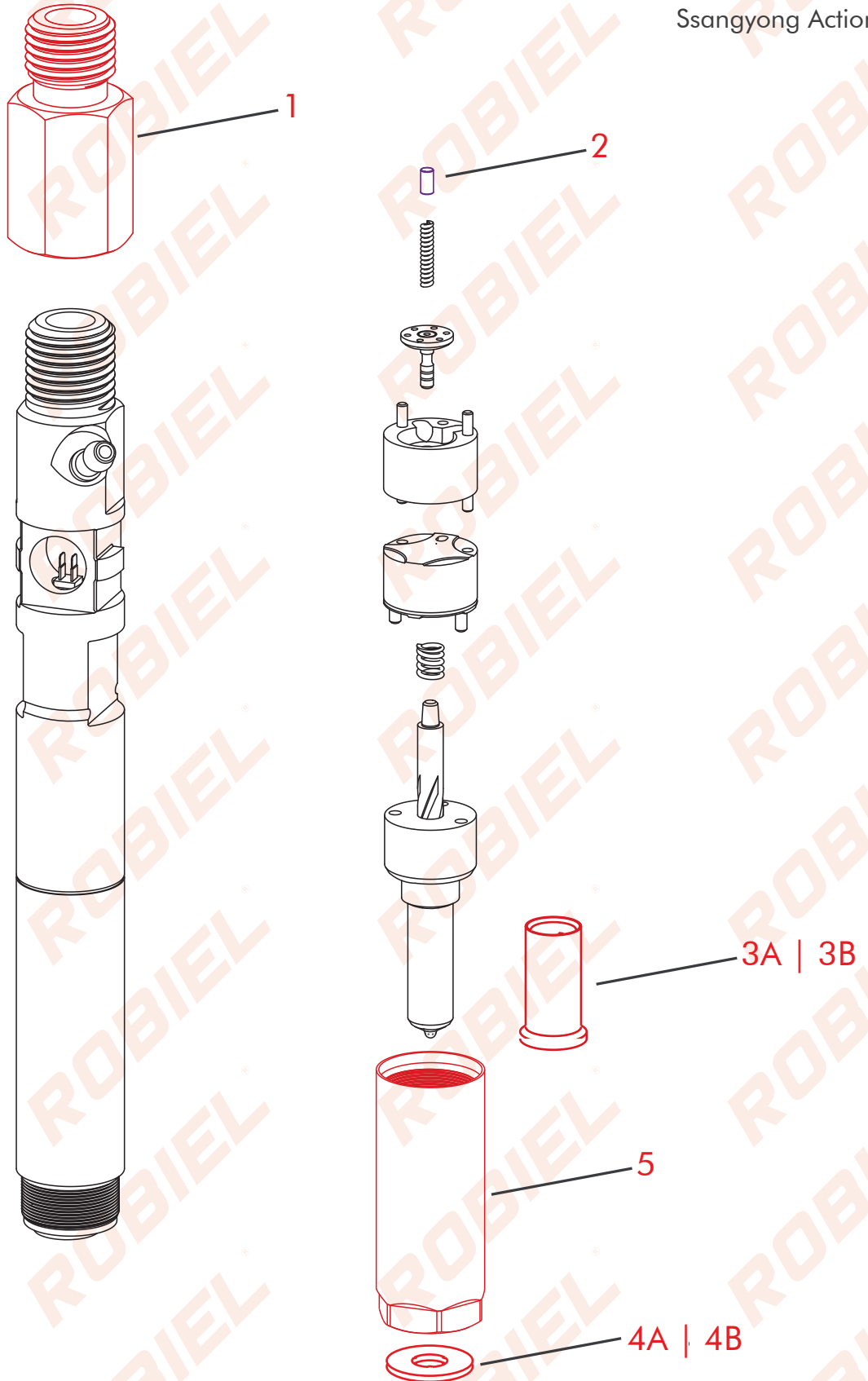

PEÇAS AVULSAS

Nº	CÓD. ROBIEL	REFERÊNCIA	DESCRIÇÃO	EMB.
1	165.02.15	Injetores c/ Caneta	Conexão com Microfiltro CR Delphi Bosch - M14x1,50mm	01pç.
3A	220.03.08	F 00R J02 537 F 00R J03 561 6.000.900.262	Capa Protetora do Bico Injetor Ø 7,00mm	01ct.
3B	220.03.09	F 00H 410 849 F 002 C88 080 6.000.900.076	Capa Protetora do Bico Injetor Ø 9,00mm	01ct.
4A	600.02.07	F 00V C17 503 F 00R J01 453	Arruela do Porta Injetor Common Rail Cummins - 1,50mm	24pç.
4B	600.02.08	F 00V C17 505 F 00R J01 086	Arruela do Porta Injetor Common Rail MWM - 2,00mm	24pç.
5	315.06.60	-	Porca do Bico Injetor Delphi - JCB / Ssangyong	01pç.



2 CALÇO DE REGULAGEM DE DEBITO DO INJETOR DELPHI
Ø Externo: 2,00

CÓD. ROBIEL	REFERÊNCIA	ESPESSURA(mm)
800.20.5360	-	3,60
800.20.5365	-	3,65
800.20.5370	-	3,70
800.20.5375	-	3,75
800.20.5380	-	3,80
800.20.5385	-	3,85
800.20.5390	-	3,90
800.20.5395	-	3,95
800.20.5400	-	4,00

EMBALAGEM COM 06 PEÇAS

UTILIZE A CÂMERA DO SEU CELULAR PARA ESCANEAR O QR CODE E OBTER MAIS INFORMAÇÕES TÉCNICAS DOS PRODUTOS EM NOSSO APLICATIVO **ROBIEL®**

BAIXE NOSSO NOVO APP



INJETORES DENSO G2

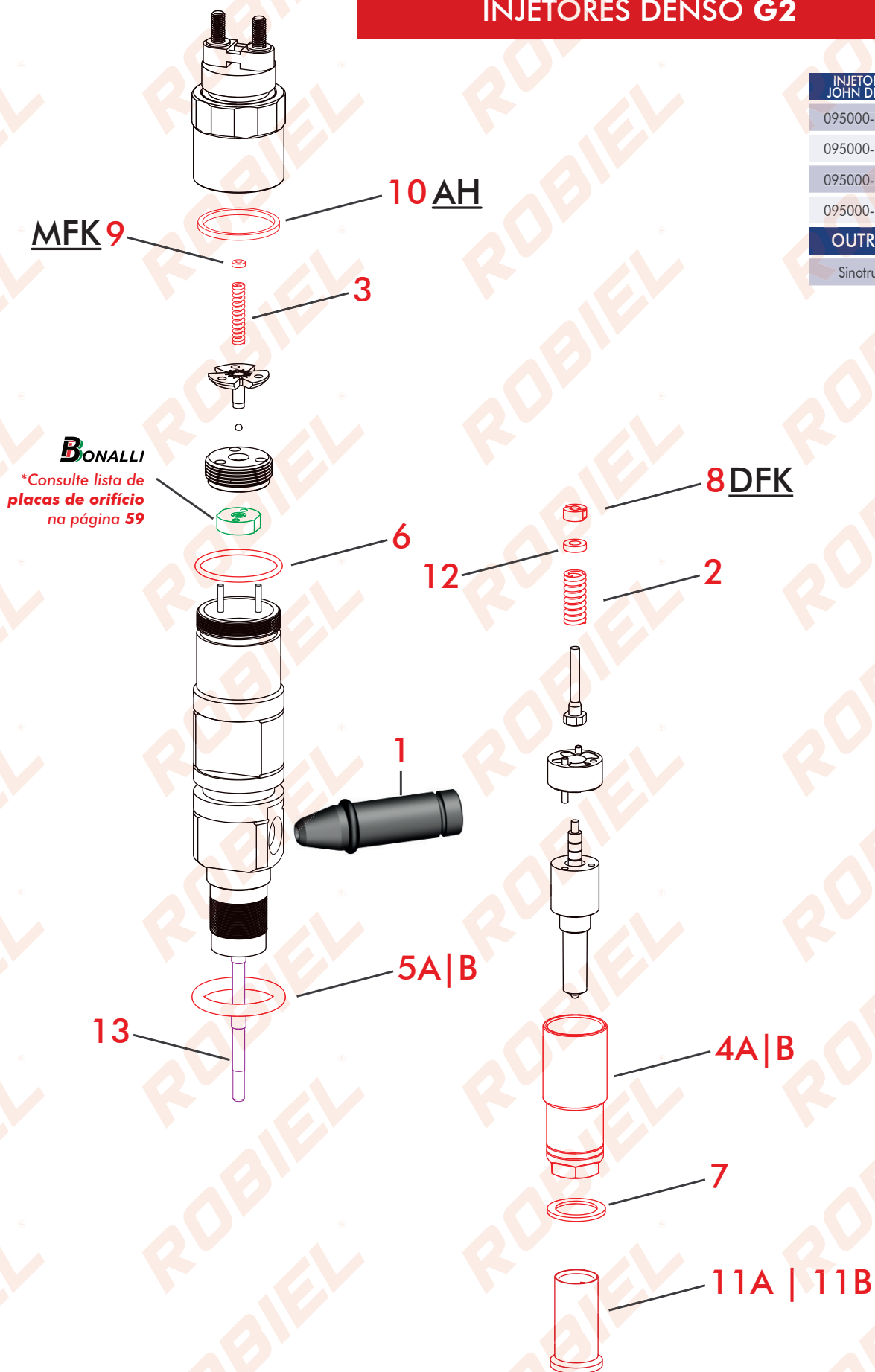

INJETORES JOHN DEERE
095000-5190
095000-6480
095000-6481
095000-6482
OUTROS
Sinotruck

410.70.461				REPARO INJETOR JOHN DEERE 9.0L - S4	
CÓD. REFERÊNCIA		095000-6460			
CÓD. ROBIEL	REFERÊNCIA	DESCRIÇÃO	EMB.		
421.00.926	-	Anel Oring	01 pç.		
421.02.035	-	Anel Oring	01 pç.		
421.02.318	-	Anel Oring	01 pç.		
807.13.20	-	Arruela	01 pç.		
220.03.08	-	Capa Protetora	01 pç.		

410.70.151				REPARO INJETOR JOHN DEERE 8.1L - HPCR	
CÓD. REFERÊNCIA		095000-5150 095000-7560 RE524361 RE518726 SE501936 RE501010			
CÓD. ROBIEL	REFERÊNCIA	DESCRIÇÃO	EMB.		
421.00.926	-	Anel Oring	01 pç.		
421.02.020	-	Anel Oring	01 pç.		
421.02.318	-	Anel Oring	01 pç.		
807.13.20	-	Arruela	01 pç.		
220.03.08	-	Capa Protetora	01 pç.		

PEÇAS AVULSAS

Nº	CÓD. ROBIEL	REFERÊNCIA	DESCRIÇÃO	EMB.
1	165.03.06	-	Conexão de Entrada do Injetor Denso John Deere	01 pç.
2	225.01.38	-	Mola do Bico Injetor Denso John Deere	06 pç.
3	225.01.39	-	Mola do Solenóide do Injetor Denso John Deere	06 pç.
4A	315.06.54	-	Porca do Bico Injetor 095000-5190	04 pç.
4B	315.06.34	-	Porca do Bico Injetores 095000-6480 6481 6482	06 pç.
5A	421.02.020	-	Anel do Injetor 095000-5190	12 pç.
5B	421.02.035	-	Anel dos Injetores 095000-6480 6481 6482	06 pç.
6	421.02.318	-	Anel do Solenóide do Injetor Denso John Deere	12 pç.
7	807.13.20	-	Arruela do Bico Injetor Denso	48 pç.
11A	220.03.08	F 00R J02 537 F 00R J03 561 6.000.900.262	Capa Protetora do Bico Injetor Ø 7,00mm	01 ct.
11B	220.03.09	F 00H 410 849 F 002 C88 080 6.000.900.076	Capa Protetora do Bico Injetor Ø 9,00mm	01 ct.

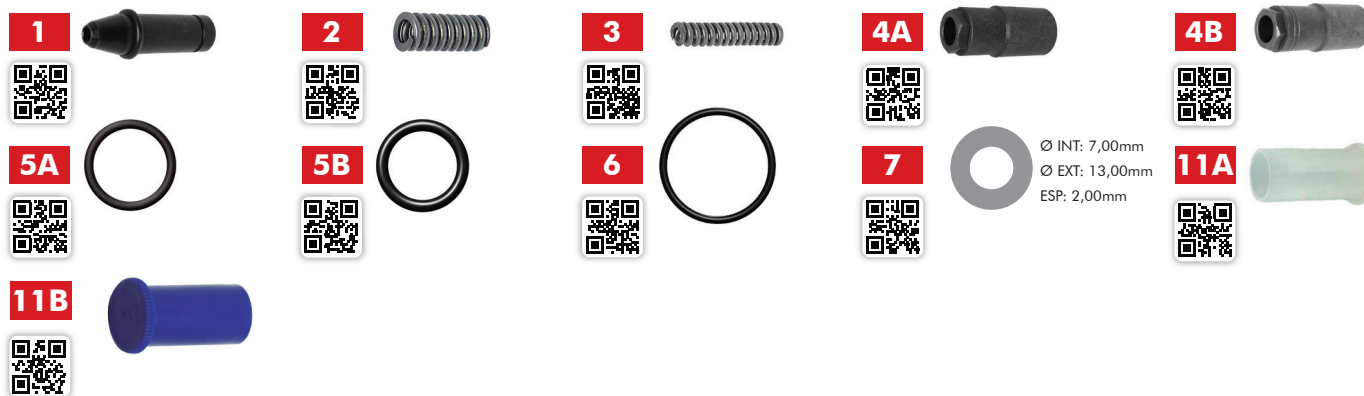

8
CALÇO DA FORÇA DA MOLLA DO BICO INJETOR (DFK)

CÓD. ROBIEL	REFERÊNCIA	ESPESSURA(mm)
800.00.290	-	2,90
800.00.295	-	2,95
800.00.300	-	3,00
800.00.305	-	3,05
800.00.310	-	3,10

EMBALAGEM COM 12 PEÇAS
9
CALÇO DA FORÇA DA MOLLA DA BOBINA (MFK)

Ø Interno: 1,80 Ø Externo: 4,00



CÓD. ROBIEL	REFERÊNCIA	ESPESSURA(mm)
801.04.11	-	1,10
801.04.115	-	1,15
801.04.12	-	1,20
801.04.125	-	1,25
801.04.13	-	1,30
801.04.135	-	1,35
801.04.14	-	1,40
801.04.145	-	1,45
801.04.15	-	1,50

EMBALAGEM COM 06 PEÇAS
10
CALÇO DE AJUSTE DO CURSO DA INDUTÂNCIA (AH)

Ø Interno: 21,40 Ø Externo: 24,30



CÓD. ROBIEL	ESPESSURA(mm)	CÓD. ROBIEL	ESPESSURA(mm)
821.24.150	1,50	821.24.161	1,61
821.24.151	1,51	821.24.162	1,62
821.24.152	1,52	821.24.163	1,63
821.24.153	1,53	821.24.164	1,64
821.24.154	1,54	821.24.165	1,65
821.24.155	1,55	821.24.166	1,66
821.24.156	1,56	821.24.167	1,67
821.24.157	1,57	821.24.168	1,68
821.24.158	1,58	821.24.169	1,69
821.24.159	1,59	821.24.170	1,70
821.24.160	1,60		

EMBALAGEM COM 10 PEÇAS
12
CALÇO DA MOLLA DO INJETOR DENSO

Ø Interno: 3,50 Ø Externo: 6,75



CÓD. ROBIEL	ESPESSURA(mm)
804.06.130	1,30
804.06.135	1,35
804.06.140	1,40
804.06.145	1,45
804.06.150	1,50
804.06.155	1,55
804.06.160	1,60
804.06.165	1,65
804.06.170	1,70

EMBALAGEM COM 06 PEÇAS

13 **BASTÃO DO INJETORES DENSO**
5160
Comprimento 79,20mm

CÓD. ROBIEL	REFERÊNCIA	ESPESSURA(mm)
BID.01.4300	-	4,300
BID.01.4302	-	4,302
BID.01.4300	-	4,300

EMBALAGEM COM 01 PEÇA

13 **BASTÃO DO INJETORES DENSO**
6490
Comprimento 66,70mm

CÓD. ROBIEL	REFERÊNCIA	ESPESSURA(mm)
BID.02.4300	-	4,300
BID.02.4302	-	4,302
BID.02.4305	-	4,305

EMBALAGEM COM 01 PEÇA

13 **BASTÃO DO INJETORES DENSO**
23670-0L020 (HILUX 3.0)
Comprimento 117,70mm

CÓD. ROBIEL	REFERÊNCIA	ESPESSURA(mm)
BID.03.4300	-	4,300
BID.03.4305	-	4,305

EMBALAGEM COM 01 PEÇA

13 **BASTÃO DO INJETORES DENSO**
16600 - EB70A (FRONTIER | TRANSIT)
Comprimento 125,85mm

CÓD. ROBIEL	REFERÊNCIA	ESPESSURA(mm)
BID.04.4300	-	4,300
BID.04.4305	-	4,305

EMBALAGEM COM 01 PEÇA

13 **BASTÃO DO INJETORES DENSO**
1465A054 (TRITON)
Comprimento 125,90mm

CÓD. ROBIEL	REFERÊNCIA	ESPESSURA(mm)
BID.05.4300	-	4,300
BID.05.4305	-	4,305

EMBALAGEM COM 01 PEÇA

13 **BASTÃO DO INJETORES DENSO**
6700 (SINOTRUK)
Comprimento 77,50mm

CÓD. ROBIEL	REFERÊNCIA	ESPESSURA(mm)
BID.06.4300	-	4,300
BID.06.4305	-	4,305

EMBALAGEM COM 01 PEÇA

13 **BASTÃO DO INJETORES DENSO**
09500-631
Comprimento 57,35mm

CÓD. ROBIEL	REFERÊNCIA	ESPESSURA(mm)
BID.08.4300	-	4,300
BID.08.4302	-	4,302
BID.08.4305	-	4,305

EMBALAGEM COM 01 PEÇA



324.44.001

Ferramenta de Retífica do Alojamento do Bastão dos Injetores Denso Ø 4,300mm
324.44.0011 - Haste Ø4,300mm



324.44.002

Ferramenta de Retífica do Alojamento do Bastão dos Injetores Denso Ø 4,305mm
324.44.0021 - Haste Ø4,305mm



UTILIZE A CÂMERA DO SEU CELULAR PARA ESCANEAR O QR CODE E OBTER MAIS INFORMAÇÕES TÉCNICAS DOS PRODUTOS EM NOSSO APLICATIVO **ROBIEL**

BAIXE NOSSO NOVO APP



INJETORES DENSO G2 | G3

Mitsubishi L200 Triton
Nissan Frontier Tailandesa
Toyota Hilux

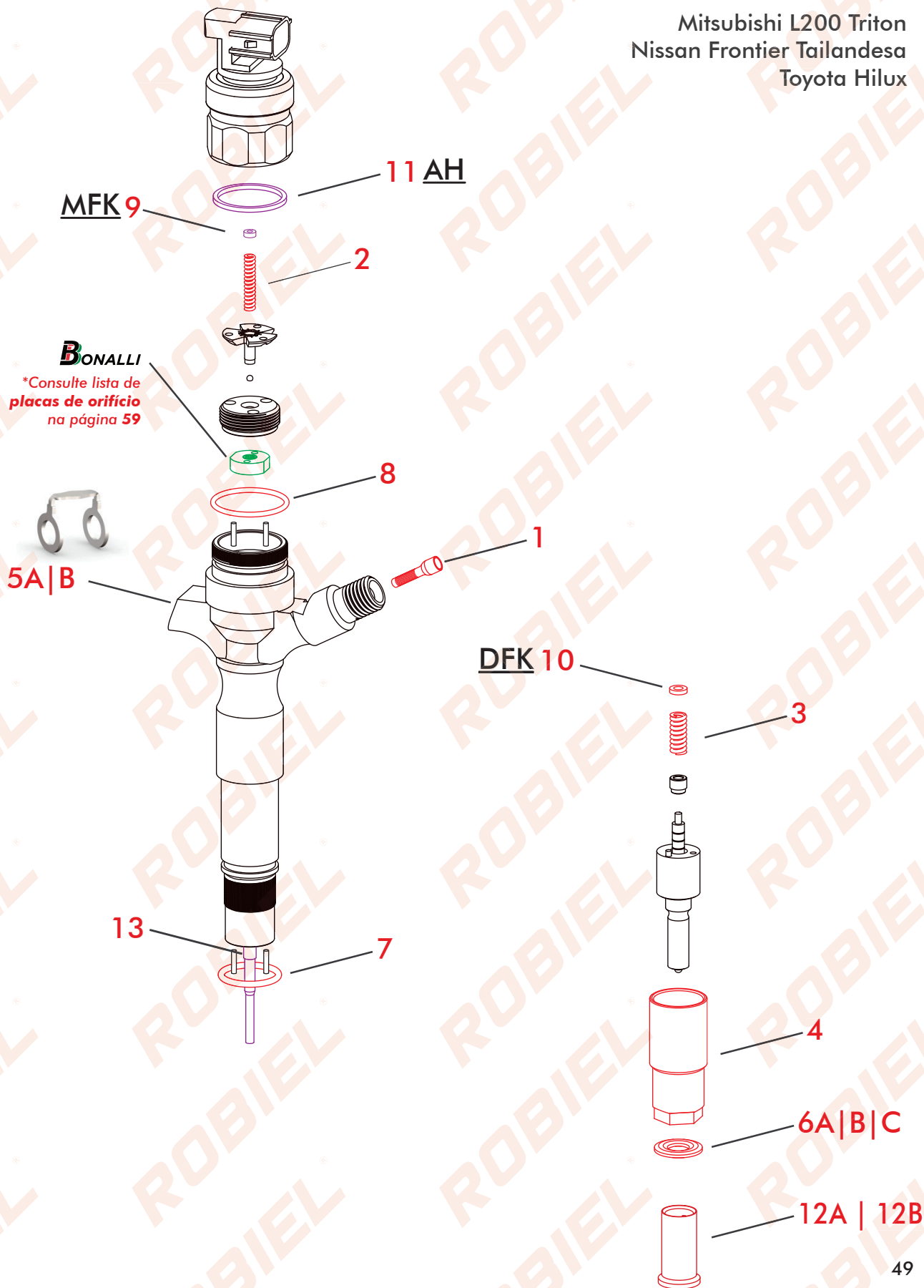

410.00.35 REPARO DO INJETOR DENSO TOYOTA HILUX				
CÓD. REFERÊNCIA				
Nº	CÓD. ROBIEL	REFERÊNCIA	DESCRIÇÃO	EMB.
5A	602.08.13	-	Arruela de Retorno	05pç.
6B	608.16.19	-	Arruela	04pç.
7	421.01.720	-	Anel O-ring	04pç.
8	421.02.318	-	Anel O-ring	04pç.



410.00.36 REPARO DO INJETOR DENSO NISSAN FRONTIER				
CÓD. REFERÊNCIA				
Nº	CÓD. ROBIEL	REFERÊNCIA	DESCRIÇÃO	EMB.
5B	602.08.14	-	Arruela de Retorno	05pç.
6A	607.14.20	-	Arruela	04pç.
7	421.01.720	-	Anel O-ring	04pç.
8	421.02.318	-	Anel O-ring	04pç.



PEÇAS AVULSAS

Nº	CÓD. ROBIEL	REFERÊNCIA	DESCRIÇÃO	EMB.
1	200.02.01	093152-0320	Filtro do Injetor Denso	04pç.
2	225.01.39	-	Mola do Solenóide Denso	06pç.
3	225.01.40	-	Mola do Calço do Bico Injetor Denso Toyota	06pç.
4	315.06.54	0 950 810 760	Porca do Bico Denso	04pç.
5A	602.08.13	-	Arruela Dupla do Cano de Retorno Toyota	08pç.
5B	602.08.14	16635-84800	Arruela Dupla do Cano de Retorno Nissan	04pç.
6A	607.14.20	MN155904	Assento do Bico L200 Triton	48pç.
6B	608.16.19	-	Assento do Bico Hilux 3.0 - 2,00mm	48pç.
6C	608.16.30	Á partir de 2016	Assento do Bico Hilux 2.8 - 3,00mm	12pç.
7	421.01.720	F 00R OPO 397	Anel do Injetor Toyota Hilux 3.0	12pç.
8	421.02.318	-	Anel de Vedação do Solenóide	12pç.
12A	220.03.08	F 00R J02 537 F 00R J03 561 6.000.900.262	Capa Protetora do Bico Injetor Ø 7,00mm	01ct.
12B	220.03.09	F 00H 410 849 F 002 C88 080 6.000.900.076	Capa Protetora do Bico Injetor Ø 9,00mm	01ct.

1



2



3



4



5A



5B



6A



Ø INT: 7,30mm
Ø EXT: 13,70mm
ESP: 1,90mm



6B



Ø INT: 7,00mm
Ø EXT: 16,00mm
ESP: 2,00mm



6C



Ø INT: 7,00mm
Ø EXT: 16,00mm
ESP: 3,00mm



7



8



12A





12B



9	CALÇO DA FORÇA DA MOLA DA BOBINA (MFK)		
	Ø Interno: 1,80 Ø Externo: 4,00		
	CÓD. ROBIEL	REFERÊNCIA	ESPESSURA(mm)
	801.04.11	-	1,10
	801.04.115	-	1,15
	801.04.12	-	1,20
	801.04.125	-	1,25
	801.04.13	-	1,30
	801.04.135	-	1,35
	801.04.14	-	1,40
	801.04.145	-	1,45
	801.04.15	-	1,50
EMBALAGEM COM 06 PEÇAS			

10	CALÇO DA FORÇA DA MOLA DO BICO (DFK)		
	Ø Interno: 3,00 Ø Externo: 5,70		
	CÓD. ROBIEL	REFERÊNCIA	ESPESSURA(mm)
	803.02.130	-	1,30
	803.02.135	-	1,35
	803.02.140	-	1,40
	803.02.145	-	1,45
	803.02.150	-	1,50
	803.02.155	-	1,55
	803.02.160	-	1,60
	803.02.165	-	1,65
	803.02.170	-	1,70
	803.02.175	-	1,75
	803.02.180	-	1,80
	803.02.190	-	1,90
	803.02.200	-	2,00
EMBALAGEM COM 06 PEÇAS			

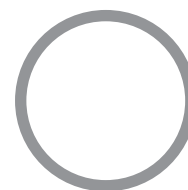
11	CALÇO DE AJUSTE DO CURSO DA INDUTÂNCIA (AH)		
	Ø Interno: 21,40 Ø Externo: 24,30		
	CÓD. ROBIEL	REFERÊNCIA	ESPESSURA(mm)
	821.24.150	-	1,50
	821.24.151	-	1,51
	821.24.152	-	1,52
	821.24.153	-	1,53
	821.24.154	-	1,54
	821.24.155	-	1,55
	821.24.156	-	1,56
	821.24.157	-	1,57
	821.24.158	-	1,58
	821.24.159	-	1,59
	821.24.160	-	1,60
	821.24.161	-	1,61
	821.24.162	-	1,62
	821.24.163	-	1,63
	821.24.164	-	1,64
	821.24.165	-	1,65
	821.24.166	-	1,66
	821.24.167	-	1,67
	821.24.168	-	1,68
	821.24.169	-	1,69
	821.24.170	-	1,70
EMBALAGEM COM 10 PEÇAS			



13 **BASTÃO DO INJETORES DENSO 5160**
Comprimento 79,20mm



CÓD. ROBIEL	REFERÊNCIA	ESPESSURA(mm)
BID.01.4300	-	4,300
BID.01.4302	-	4,302
BID.01.4300	-	4,300

EMBALAGEM COM 01 PEÇA



13 **BASTÃO DO INJETORES DENSO 6490**
Comprimento 66,70mm



CÓD. ROBIEL	REFERÊNCIA	ESPESSURA(mm)
BID.02.4300	-	4,300
BID.02.4302	-	4,302
BID.02.4305	-	4,305

EMBALAGEM COM 01 PEÇA



13 **BASTÃO DO INJETORES DENSO 23670-0L020 (HILUX 3.0)**
Comprimento 117,70mm



CÓD. ROBIEL	REFERÊNCIA	ESPESSURA(mm)
BID.03.4300	-	4,300
BID.03.4305	-	4,305

EMBALAGEM COM 01 PEÇA



13 **BASTÃO DO INJETORES DENSO 16600 - EB70A (FRONTIER | TRANSIT)**
Comprimento 125,85mm



CÓD. ROBIEL	REFERÊNCIA	ESPESSURA(mm)
BID.04.4300	-	4,300
BID.04.4305	-	4,305

EMBALAGEM COM 01 PEÇA



13 **BASTÃO DO INJETORES DENSO 1465A054 (TRITON)**
Comprimento 125,90mm



CÓD. ROBIEL	REFERÊNCIA	ESPESSURA(mm)
BID.05.4300	-	4,300
BID.05.4305	-	4,305

EMBALAGEM COM 01 PEÇA



13 **BASTÃO DO INJETORES DENSO 6700 (SINOTRUK)**
Comprimento 77,50mm



CÓD. ROBIEL	REFERÊNCIA	ESPESSURA(mm)
BID.06.4300	-	4,300
BID.06.4305	-	4,305

EMBALAGEM COM 01 PEÇA



13 **BASTÃO DO INJETORES DENSO 09500-631**
Comprimento 57,35mm



CÓD. ROBIEL	REFERÊNCIA	ESPESSURA(mm)
BID.08.4300	-	4,300
BID.08.4302	-	4,302
BID.08.4305	-	4,305

EMBALAGEM COM 01 PEÇA



324.44.001
Ferramenta de Retífica do Alojamento do Bastão dos Injetores Denso Ø 4,300mm
324.44.0011 - Haste Ø4,300mm



324.44.002
Ferramenta de Retífica do Alojamento do Bastão dos Injetores Denso Ø 4,305mm
324.44.0021 - Haste Ø4,305mm



415.00.031 KIT DE CALÇOS PARA REPARAÇÃO DE INJETORES DENSO | SIEMENS

Nº	CÓDIGOS	DESCRIÇÃO	ESPESSURAS(mm)	Peças por Medida
AH	821.24.150 - 821.24.170	Calço do Solenóide do Injetor	1,50 à 1,70	12 peças
MFK	801.04.12 - 801.04.15	Calço da Pré-Injeção do Injetor	1,20 à 1,50	12 peças
DFK	800.00.290 - 800.00.310	Calço do Injetor Denso G2	2,90 à 3,10	12 peças
DFK	803.02.130 - 803.02.160	Calço Ajuste do Bico Denso G2 G3 Siemens	1,30 à 1,60	12 peças
-	814.18.090 - 814.18.100	Calço de Ajuste Piezo Elétrico Siemens	0,90 à 1,00	12 peças

TOTAL DE 612 PEÇAS

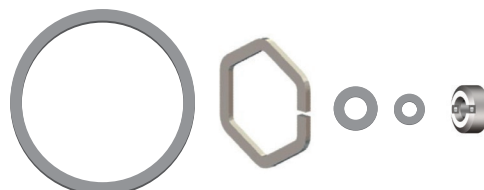

323.01.3241

Morsa Giratória para Bancada com Pino Trava



324.15.01

Suporte de Montagem e Desmontagem de Injetores



324.15.04

Mordente para Injetores Denso



324.13.322

Ferramenta da Válvula do Injetor Denso



323.02.121

Escova para Limpeza e Remoção de Resíduos Ø 12,00mm



323.50.20

Kit de Reparação do Filtro do Injetor Denso



323.50.083

Kit de Reparação para Injetores Denso G1 | G2 | G3 Siemens/Continental



UTILIZE A CÂMERA DO SEU CELULAR PARA ESCANEAR O QR CODE E OBTER MAIS INFORMAÇÕES TÉCNICAS DOS PRODUTOS EM NOSSO APLICATIVO **ROBIEL**

BAIXE NOSSO NOVO APP



INJETORES SIEMENS VDO | CONTINENTAL

Ford Ranger

INJETORES

SW 5006

77550

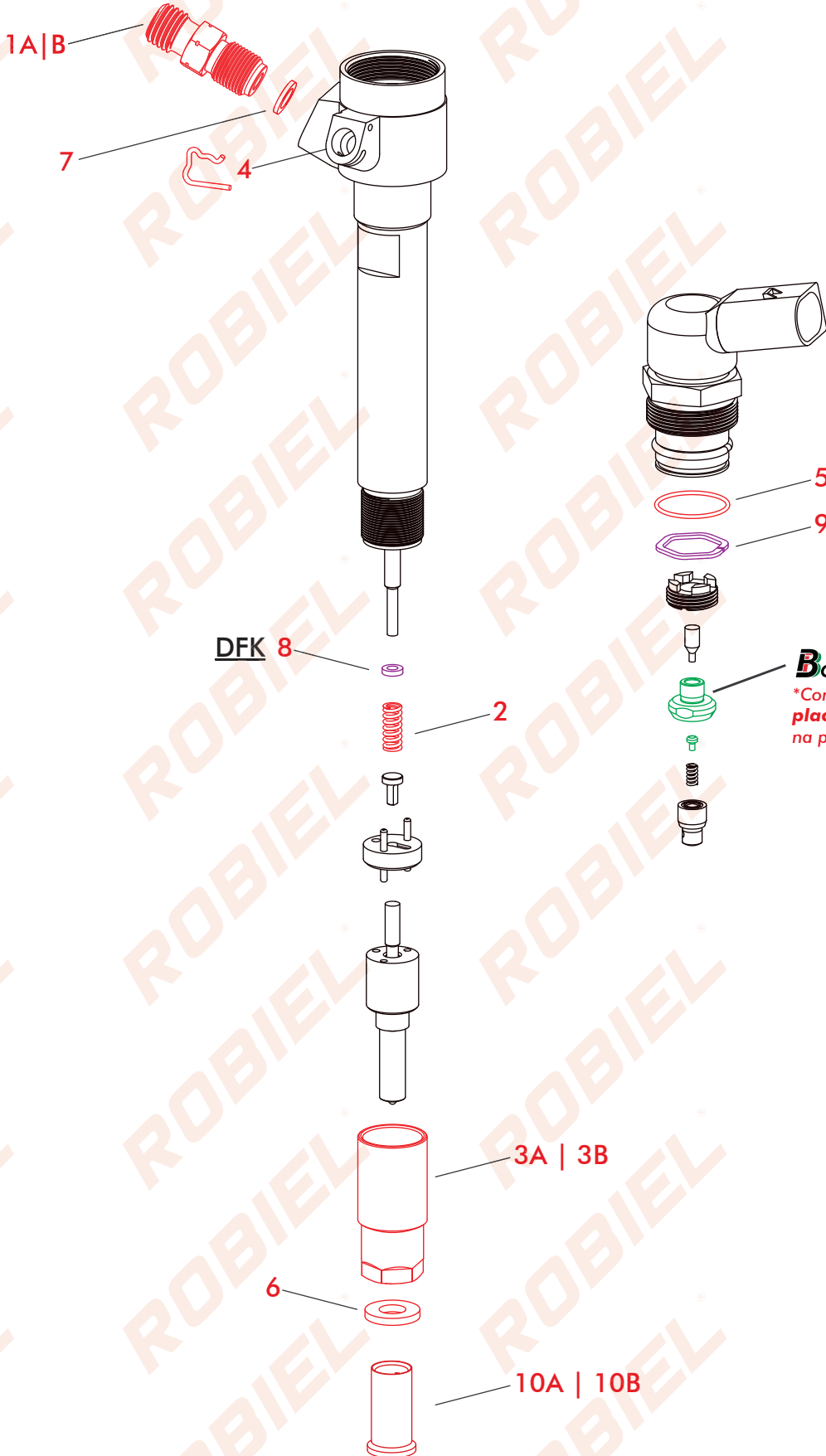

BONALLI
*Consulte lista de placas de orifício na página 59

PEÇAS AVULSAS

Nº	CÓD. ROBIEL	REFERÊNCIA	DESCRIÇÃO	EMB.
1A	165.02.06	F 00V C16 017	Conexão de Pressão do Injetor	01pç.
1B	165.02.061	-	Conexão c/ Microfiltro Injetores Bosch Siemens <small>M12X 1,50mm M12 X 1,00mm</small>	01pç.
2	225.01.41	-	Mola do Bico do Injetor Siemens	06pç.
3A	315.06.55	-	Porca do Bico Injetor Siemens	04pç.
3B	315.06.61	BK2Q9K546AG A2C59517051 5WS40745	Porca do Bico Ford Ranger / Transit / Troller - 2.2 3.2	04pç.
4	335.03.00	-	Trava do Retorno do Bico Injetor Siemens	04pç.
5	421.01.851	-	Anel do Solenóide do Injetor Siemens	12pç.
6	607.15.20	-	Assento do Bico Siemens Ford Ranger	01ct.
7	805.09.05	F 00V C17 003 F 00R 0P0 004	Calço da Conexão do Injetor	12pç.
10A	220.03.08	F 00R J02 537 F 00R J03 561 6.000.900.262	Capa Protetora do Bico Injetor Ø 7,00mm	01ct.
10B	220.03.09	F 00H 410 849 F 002 C88 080 6.000.900.076	Capa Protetora do Bico Injetor Ø 9,00mm	01ct.



9 CALÇO DO AJUSTE DO PIEZO ELÉTRICO SIEMENS

Ø Interno: 16,00 Ø Externo: 18,00





CÓD. ROBIEL	REFERÊNCIA	ESPESSURA(mm)	CÓD. ROBIEL	REFERÊNCIA	ESPESSURA(mm)
814.18.080	-	0,80	814.18.099	-	0,99
814.18.085	-	0,85	814.18.100	-	1,00
814.18.090	-	0,90	814.18.101	-	1,01
814.18.091	-	0,91	814.18.102	-	1,02
814.18.092	-	0,92	814.18.103	-	1,03
814.18.093	-	0,93	814.18.105	-	1,05
814.18.094	-	0,94	814.18.110	-	1,10
814.18.095	-	0,95	814.18.115	-	1,15
814.18.096	-	0,96	EMBALAGEM COM 06 PEÇAS		
814.18.097	-	0,97			
814.18.098	-	0,98			

EMBALAGEM COM 06 PEÇAS

8 CALÇO DA FORÇA DA MOLA DO BICO SIEMENS 5W S5000 7750 (DFK)		
Ø Interno: 3,00 Ø Externo: 5,70		
CÓD. ROBIEL	REFERÊNCIA	ESPESSURA(mm)
803.02.130	-	1,30
803.02.135	-	1,35
803.02.140	-	1,40
803.02.145	-	1,45
803.02.150	-	1,50
803.02.155	-	1,55
803.02.160	-	1,60
EMBALAGEM COM 06 PEÇAS		

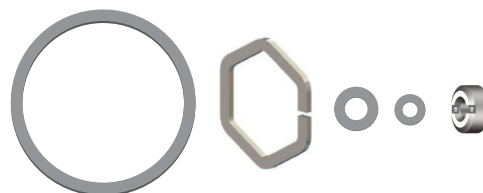

415.00.031 KIT DE CALÇOS PARA REPARAÇÃO DE INJETORES DENSO SIEMENS				
Nº	CÓDIGOS	DESCRIÇÃO	ESPESSURAS(mm)	Peças por Medida
-	821.24.150 - 821.24.170	Calço do Solenóide do Injetor	1,50 à 1,70	12 peças
-	801.04.12 - 801.04.15	Calço da Pré-Injeção do Injetor	1,20 à 1,50	12 peças
-	800.00.290 - 800.00.310	Calço do Injetor Denso John Deere	2,90 à 3,10	12 peças
DFK	803.02.130 - 803.02.160	Calço de Ajuste do Bico Ford Ranger	1,30 à 1,60	12 peças
-	814.18.090 - 814.18.100	Calço de Ajuste Piezo Elétrico Siemens	0,90 à 1,00	12 peças
TOTAL DE 612 PEÇAS				



323.50.083

Kit de Reparação para Injetores Denso G1 | G2 | G3
Siemens/Continental





SOLUÇÕES PARA SISTEMAS COMMON RAIL

Oferecemos ao segmento diesel diversos produtos para sistemas Common Rail voltados a oficinas e reparadores que buscam melhores alternativas, em comparação as marcas já existentes no mercado, seja em preço ou na qualidade de seus produtos.

Distribuídos no Brasil pela Robiel Injeção Diesel, empresa que atua há mais de 33 anos no setor, nossos produtos proporcionam um excelente custo benefício, tornando o processo de reparação mais simples e ágil, além de oferecer uma maior lucratividade e otimização de processos a seus clientes.

Tendo como objetivos principais a prática de preços acessíveis e uma qualidade similar aos originais, visamos nos tornar referência tanto para oficinais que não possuem a cultura de reparação e remanufatura de componentes de injeção diesel, quanto aos reparadores que se deparam com dificuldades em encontrar produtos com resistência, durabilidade e qualidade no mercado.

**CONJUNTO DE
VÁLVULAS**



**PLACAS DE
ORIFÍCIO**



TUBOS



**VÁLVULAS
MPROP**



Estes componentes do sistema common rail são fundamentais para o perfeito funcionamento dos modernos sistemas diesel e garantem o melhor rendimento do combustível, potência do motor e cumprimento das leis de emissões.

Código Original: F 00R J00 005

B01.04.0005

Número do Injetor	O 986 435 501 O 445 120 002	Motor	2.8 JTD
--------------------------	--------------------------------	--------------	---------

Aplicações	Ducato / Jumper / Boxer	2005 - 2009
-------------------	-------------------------	-------------



Código Original: F 00R J00 339

B01.04.0339

Número do Injetor	O 445 120 007	Motor	ISBe4 ISB6 - F4A
--------------------------	---------------	--------------	------------------

Aplicações	Agrale MA e MT12	01/2005 - 12/2009
	Iveco 170E25 e 240E25 e 170E22	12/2008 - 04/2012
	Eurocargo 170E22	01/2005
	Eurocargo 230E22	03/2006 - 12/2009
	Eurocargo 230E24 New Holland T7060	03/2006 - 12/2011 10/2007 - 12/2014



Código Original: F 00V C01 022

B01.04.1022

Número do Injetor	O 445 110 141	Motor	G9U - 2.5 16V
--------------------------	---------------	--------------	---------------

Aplicações	Renault Master - Euro 3	2005 - 2011
-------------------	-------------------------	-------------



Código Original: F 00V C01 023

B01.04.1023

Número do Injetor	O 445 110 231	Motor	MWM 4.07 TCE - SPRINT EURO 3
--------------------------	---------------	--------------	------------------------------

Aplicações	VW-Delivery 5.140/8.150	10/2005 - 12/2011
	Chevrolet S10	08/2005 - 01/2012
	Chevrolet Blazer	08/2005 - 05/2009



Código Original: F 00V C01 051

B01.04.1051

Número do Injetor	O 445 110 190	Motor	OM612 LA CDI 2.2 16V - 4 CIL. OM612 LA CDI 2.7 20V - 5 CIL.
--------------------------	---------------	--------------	--

Aplicações	MBB - Sprinter 311/313/413 - Euro 3	2002 - 2011
	MBB - Accelo 715 - Euro 3	2002 - 2011
	Gran Cherokee - 2.7 20V	2002 - 2004



Código Original: F 00R J01 278

B01.04.1278

Número do Injetor	O 445 120 054	Motor	NEF 4 / NEF 6
--------------------------	---------------	--------------	---------------

Aplicações	Iveco Tector 170E22/170E28/240E22/240E28/260E28	05/2012
	Vertis 90V16 / 130V18	10/2010 - 09/2012
	130V19 / 90V18	10/2012
	Case 2855491 / IH 2855491	



Código Original: F 00V C01 353

B01.04.1353

Número do Injetor	O 445 110 265	Motor	2.5 - G9U
--------------------------	---------------	--------------	-----------

Aplicações	Master 2,5 16V	2012 a 2013
-------------------	----------------	-------------



B01.04.1379

Código Original: F 00V C01 379



Número do Injetor	O 445 110 424	Motor	2.8 CTDI
Aplicações	Chevrolet - S10 / Trail Blazer		2012 - 2013

B01.04.1383

Código Original: F 00V C01 383



Número do Injetor	O 445 110 376	Motor	ISF 2.8 - Euro 5 - 150CV
Aplicações	Cummins F350/F4000		12/2014

B01.04.1338

Código Original: F 00V C01 338



Número do Injetor	O 445 110 248	Motor	F1CE0481 - 3.0 - Euro 3
	O 445 110 273		F1AE0481T - 2.3 - Euro 3
Aplicações	Iveco Daily 3.0 - City Class / Daily 35S14 / 40S16 / 45S14 / 45S16 / 55S16 Scudato 70C16 Ducato / Jumper / Boxer		08/2007 - 03/2012 10/2009 - 02/2012

B01.04.1895

Código Original: F 00R J01 895



Número do Injetor	O 445 120 016	Motor	MWM 4.12
	O 445 120 017		6.12 TCE
Aplicações	VW 15.190 VW 17.230		2004 - 2012

B01.04.1941

Código Original: F 00R J01 941



Número do Injetor	O 445 120 120	Motor	ISC 8.3
	O 445 120 140		
Aplicações	VW 18.320EOT Constellation 19.320 Titan Constellation 25.320 Constellation 31.320 Ford Cargo 28/40/43 e 5332		02/2006 - 12/2011 10/2005 - 12/2011 03/2008 - 08/2011 01/2007 - 12/2011

B01.04.2103

Código Original: F 00R J02 103



Número do Injetor	O 445 120 134	Motor	ISF 3.8
	O 445 120 297		
	O 445 120 321		
	O 445 120 360		
	O 445 120 361		
	O 445 120 372		
	O 445 120 416		
	O 445 120 426		
	O 445 120 445		
	O 445 120 482		
	O 445 120 498		
	O 445 120 499		
	Aplicações		

Código Original: F 00R J02 130
B01.04.2130

Número do Injetor	O 445 120 212	Motor	ISB4 / ISB6 / F4A
Aplicações	VW 8150 / 24250 / 23250		2004 - 2011
	Ford 1317e / 1717e / 2422e / 2428e		2004 - 2011
	Agrale MT 12.0e		2004 - 2011
	Iveco Tector 170E22		2004 - 2011
	Eurocargo 170E22 / 230E22 / 230E24		2004 - 2011
	New Holland T7060		2004 - 2011

Código Original: F 00R J02 449
B01.04.2449

Número do Injetor	O 445 120 162 O 445 120 186 O 445 120 315 O 445 120 316 O 445 120 484 O 445 120 491	Motor	D0834
Aplicações	VW Constellation 13/15.190		2012 ->

Código Original: F 00R J02 506
B01.04.2506

Número do Injetor	O 445 120 106 O 445 120 199 O 445 120 257 O 445 120 310	Motor	ISC 8.3 I e ISL
Aplicações	Cargo 1832		01/2010 - 12/2011
	Cargo 1932		04/2011
	2632/2932/3132/4432/4532/ Max ton 5032/ 6332		02/2006 - 12/2011
	VW 18.320 EOT		02/2007 - 12/2011
	Constellation 17.320/19.320/24.320/25.320.31.320		02/2007 - 12/2011



B03.03.P140

Número do Injetor	A2C59517051	Motor	Puma 2.2, Puma 3.0 3.2 16V - Euro 5
Aplicações	Ford Ranger / Transit 2.2 / 3.0 / 3.2 - Euro 5 2012 - 2017		

B05.03.L020

Número do Injetor	095000-544	Motor	1 KD-FTV
	095000-592		
	095000-822		
	095000-829		
	095000-778		
	095000-754		

Aplicações	Hilux Land Cruiser 3.0	2005 - 2010
-------------------	------------------------	-------------

B05.03.L090

Número do Injetor	295050-018	Motor	1KD - 3.0 / 2KD - 2.5
	295050-052		
	295050-020		
	295050-046		

Aplicações	Hilux 3.0 / Land Cruiser / Vigo 3.0 VNT - Euro 4	2010 - 2012
-------------------	--	-------------

B05.03.0576

Número do Injetor	095000-576	Motor	4M41 - 3.2
	095000-811		

Aplicações	Pajero Sport / Dakar / Full / Montero	2012-2016
-------------------	---------------------------------------	-----------

B05.03.0560

Número do Injetor	095000-560	Motor	4D56 - 2.5
--------------------------	------------	--------------	------------

Aplicações	L200 Triton	2008 - 2018
-------------------	-------------	-------------

B05.03.0580

Número do Injetor	095000-580	Motor	Puma 2.4 16V
--------------------------	------------	--------------	--------------

Aplicações	Ford transit / Land Rover Defender - Euro 3	2007 - 2011
	Citroën Jumper	2007 - 2011

B05.03.0625

Número do Injetor	095000-625	Motor	YD 2.5 DDTI - 16V DOHC
--------------------------	------------	--------------	------------------------

Aplicações	Nissan Frontier / Navara / Pathfinder YD 25	2005 - 2013
-------------------	---	-------------

B05.03.0648

Número do Injetor	095000-648	Motor	JD 6090
--------------------------	------------	--------------	---------

Aplicações	John Deere 8530 S450 2005_11 / Tractor	2006 - 2009
-------------------	--	-------------



VÁLVULAS MPROP

B01.07.0481

Código Original: 0 928 400 481



Aplicações

Volkswagen - Constellation - 2001 -2020

Motor

D08 36 280



* Escaneie o QR Code e confira através do APP da ROBIEL mais aplicações deste produto.

B01.07.0487

Código Original: 0 828 400 487



Aplicações

Renault - Master 2.5 16V DOHV L4 - 2004 - 2012

Motor

G9U-724

B01.07.0508

Código Original: 0 928 400 508



Aplicações

MBB - Sprinter CDI 2.2L 16V - 2002 - 2020

Motor

OM 611 LA

Motor

OM 651 LA

B01.07.0644

Código Original: 0 928 400 644



Aplicações

Ford Cargo Interact 4 - 2005 - 2011

Motor

INTERACT 4 ISBe



* Escaneie o QR Code e confira através do APP da ROBIEL mais aplicações deste produto.

B01.07.0666

Código Original: 0 928 400 666



Aplicações

Dodge Ram - RAM - 5.9L 24V SOHV L6 - 2004 - 2010

Motor

ETH

B01.07.0667

Código Original: 0 928 400 667



Aplicações

Fiat Ducato 2.3L 16V DOHC L4 - EURO V - 2009 - 2012

Motor

F1A MULTIJET

Aplicações

Citroen Jumper 2.3L 16V DOHC L4 - 2010 - 2012

Motor

F1A MULTIJET

Aplicações

Peugeot Boxer 2.3L 16V DOHV L4 - 2010 - 2012

Motor

F1A MULTIJET

B01.07.0726

Código Original: 0 928 400 726



Aplicações

Fiat Ducato 2.3L 16V DOHC L4 - EURO III - 2009 - 2012

Motor

F1A MULTIJET

Aplicações

Citroen Jumper 2.3L 16V DOHC L4 - 2010 - 2012

Motor

F1A MULTIJET

Aplicações

Peugeot Boxer 2.3L 16V DOHV L4 - 2010 - 2012

Motor

F1A MULTIJET

VÁLVULAS MPROP

B01.07.0739

Código Original: 0 928 400 739



Aplicações	Iveco Daily 3.0L 16V DOHC L4 - 2007 - 2020	Motor	F1C E 0481
		Motor	F1C DS
		Motor	F1C DS - EGR
Aplicações	Scudato 2.8L 8V SOHC L4 - 2001 - 2008	Motor	8140.43
		Motor	8140.43S
Aplicações	Hyundai HD 78 - 3.0L 16V DOHC L4 - 2011 - 2020	Motor	D4GA

B01.07.0768

Código Original: 0 928 400 768



Aplicações	Volkswagen Amarok - 2.0L 16V DOHC L4 - 2010-2020	Motor	EA189

B01.07.0789

Código Original: 0 928 400 789



Aplicações	Volkswagen 17.230 EOD - 7.2L 12V SOHV L6 - 2006-2001	Motor	■
-------------------	--	--------------	---

* Escaneie o QR Code e confira mais aplicações para este produto.



B01.07.2500

Código Original: 0 281 002 500



Aplicações	Fiat Ducato - 2.8L 8V SOHC L4 - 2000 - 2008	Motor	8140.23
		Motor	8140.43
		Motor	8140.63
Aplicações	Iveco Daily - 2.8L 8V SOHC L4 - 2000 - 2008	Motor	8140.23 8140.43

B01.07.6074

Código Original: 0 281 000 074



Aplicações	Volkswagen Amarok - 2.0L 16V DOHC L4 - 2010 - 2020	Motor	EA189
-------------------	--	--------------	-------

B03.07.0005

Código Original: X39-800-300-005Z



Aplicações	Ford Ranger - 3.0L 16V DOHC L4 - 2005 - 2012	Motor	POWER STROKE
Aplicações	Troller - 3.0L 16V DOHC L4 - 2006 - 2012	Motor	POWER STROKE

VÁLVULAS MPROP

B03.07.0006

Código Original: X39-800-300-006Z



Aplicações	Ford Ranger - 3.0L 16V DOHC L4 - 2005 - 2012	Motor	POWER STROKE
-------------------	--	--------------	--------------

B03.07.9358

Código Original: BK2Q-9358-AA



Aplicações	Ford Ranger - 2.2L 16V DOHC L4 - 2012 - 2016	Motor	DURATORQ
-------------------	--	--------------	----------

Aplicações	Ford Ranger - 3.2L 20V DOHC L5 - 2012 - 2016	Motor	DURATORQ
-------------------	--	--------------	----------

Aplicações	Ford Transit - 2.2L 16V DOHC L4 - 2012 - 2016	Motor	DURATORQ
-------------------	---	--------------	----------

B05.07.0360

Código Original: 294200-0360



Aplicações	Nissan Frontier - 2.5L DOHC L4 - 2007 - 2019	Motor	YD25ETI
-------------------	--	--------------	---------

Aplicações	Toyota Hilux - 2.5L 16V DOHC L4 - 2005 - 2011	Motor	D4D
-------------------	---	--------------	-----

B05.07.0650

Código Original: 294200-0360



Aplicações	JCB	Motor	ISUZU 4HK1
-------------------	-----	--------------	------------

Motor	ISUZU 6HK1
--------------	------------

TUBOS

B06.09.0001

Código Original: 3970729



Aplicações	VW Constalattion 17-250E / 24-250E	Motor	Cummins ISB 5.9L 6 cil.
Aplicações	VW Worker 17-250E / 23-250E / 24-250 E	Motor	Cummins ISB 5.9L 6 cil.

B06.09.0002

Código Original: 3972002



Aplicações	Constallation 17-250E (2006-2012)	Motor	Interact 6
Aplicações	Delivery 9.150 (2014-2016)	Motor	Interact 4
Aplicações	Worker 17.250E (2006-2012)	Motor	Interact 4
Aplicações	Worker 9.150 (2003-2011)	Motor	Interact 4
Aplicações	VW 15.170 (2000-2006)	Motor	Interact 4



* Escaneie o QR Code e confira mais aplicações para este produto.

B06.09.0003

Código Original: 3964119



Aplicações	Ford Cargo 815E - 1317E - 1517E - 1717E - 1722E - 2422E 2428E - 2622E - 2628E - 2005 - 2006 - 2007 - 2008 2009 - 2010 - 2011	Motor	Interact 4
Aplicações	Ford Novo Cargo 1317 4x2 - 1517 4x2 - 1717 4x2 - 2021 em diante	Motor	5.9 ISBE
Aplicações	Ford 1722 4x2 - 2422 6x2 - 2428 6x2 - 2622 6x4 - 2628 6x4 - 2021 em diante	Motor	Interact 6

MANGUEIRAS DE RETORNO

B06.09.0004

Código Original: BB3Z9A564E / BK3Q9A564E



Aplicações	Ford Ranger	Motor	2.2 L - 16 V
-------------------	-------------	--------------	--------------

B06.09.0005

Código Original: 03L130235AD



Aplicações	Amarok - 2012 a 2018	Motor	EA189 - 2.0 16 V 180cv
-------------------	----------------------	--------------	------------------------

B06.09.0006

Código Original: BB3Q9K022BG / BB3Q9K022BH

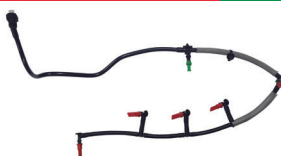

Aplicações	Ranger 3.2	Motor	DURATORQ
-------------------	------------	--------------	----------